

Off-site Pre Assembly (Available on Request)

It is an accepted rule of physics that a material, when subjected to a change of temperature, will expand or contract directly related to the temperature. Pipework is therefore subject to the same principal.

Factors to be considered when calculating the amount of expansion are as follows:

1. The amount of temperature change – based upon the lowest ambient temperature.
2. The overall length of pipe upon which calculations are to be based.
3. The co-efficient of expansion for the required material.

Carbon Steel Pipes

The co-efficient of expansion for carbon steel is: $0 - 100^{\circ}\text{C} = \text{Cof}\Delta 1.11$
 (These Co-efficients can be used for standard stainless steels) $101^{\circ}\text{C} + = \text{Cof}\Delta 1.21$

Copper Pipes

Copper expands at a 50% higher rate, the equation would be: $0 - 100^{\circ}\text{C} = \text{Cof}\Delta 1.11 \times 1.5$
 (These Co-efficients can be used for thin wall stainless steels) $101^{\circ}\text{C} + = \text{Cof}\Delta 1.21 \times 1.5$

Plastic Pipes

The rate of expansion for plastics differs between materials and manufacturers; it is always advisable to check the rate of thermal expansion with the manufacturer.

The following table shows the expansion ratio in mm/m. This can be used instead of calculating individual sections of pipe.

Expansion Ratio of Pipe			
Steam or Water Temperature		Expansion in mm/m	
$^{\circ}\text{C}$	$^{\circ}\text{F}$	Steel Pipes	Copper Pipes
0	0	0	0
65	149	0.72	1.08
82	180	0.91	1.37
120	248	1.45	2.18
134	272	1.62	2.43
144	290	1.74	2.61
152	305	1.83	2.76
170	338	2.05	3.09
184	363	2.23	3.34
198	388	2.39	n/a
205	405	2.48	n/a
217	422	2.62	n/a
226	439	2.73	n/a

By using the table above we can extract the movement ratio in mm/m and multiply by the total length of pipework:

Example 1

To calculate the expansion on a 75m length of carbon steel pipe passing 10bar steam:

Temperature Rise = 184°C
 Expansion in mm/m = 2.23mm/m
 Pipe Length = 75m
 Total Expansion = $75 \times 2.23 = 167.5\text{mm}\Delta$

Example 2

To calculate the expansion on a 25m length of copper pipe supplying LTHW at 82°C :

Temperature Rise = 82°C
 Expansion in mm/m = 1.37mm/m
 Pipe Length = 25m
 Total Expansion = $25 \times 1.37 = 34.25\text{mm}\Delta$

Pipework & Expansion Guide

Natural Flexibility

Pipework systems have various changes in direction within itself. As this occurs pipework systems should have some natural flexibility within it. The following pages will help the engineer use the changes in direction to naturally flex the expansion that will occur.

Expansion within hot pipework is always present. Expansion rates of 74.4mm over a length of 30mtrs steel pipework carrying steam at 205°C needs channelling somewhere.

Items which need to be addressed by the engineer:

- A. Method of pipework bracketing to allow natural flexibility to occur.
- B. Pipework material
- C. Pipework nominal size.
- D. Location and layout of pipework including length.
- E. Minimum and maximum temprature of pipework, media and ambient. Applicable to ambient temperatures 0°C and under.
- F. Working and test pressure of pipework media
- G. Connection points to plant etc.
- H. Structure of building.

Once we have addressed all these items then we can look at solutions.

To help take into account the above items, the engineer should use pipework anchors. Pipework anchors can separate large complicated pipework systems into smaller more manageable systems.

Positioning the anchors so an offset occurs between the anchors could naturally compensate the expansion.

The forces imposed upon an anchor is primarily made up from two areas:

- A. Force to Deflect pipework offset.
- B. Frictional force due to pipework bracketry.

Forces subjected onto the anchor positions can be calculated using the following formulae:-

$$F = \frac{24IX}{L^3} \quad \text{For carbon steel pipes.}$$

$$F = \frac{8.4IX}{L^3} \quad \text{For copper pipes.}$$

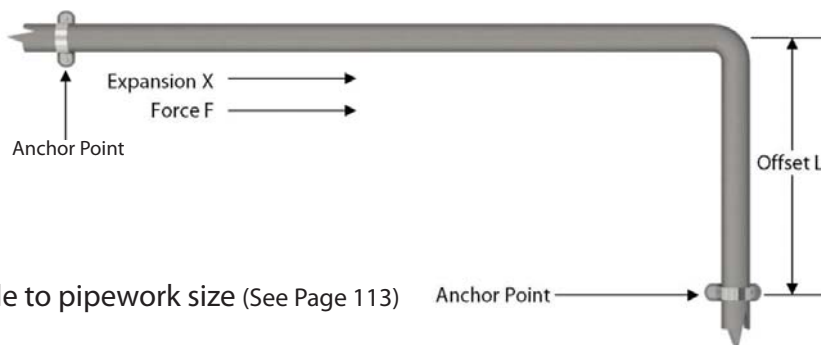

F = Force in Newtons

I = Moment of Inertia in cm⁴ Applicable to pipework size (See Page 113)

X = Expansion in mm

L = Length of offset in metres (shortest length)

You will also need to add to this result the force is encountered via frictional resistance of pipework bracketry on the pipework.

Examples of frictional resistance can be calculated using the following formulae:-

$$F = L \times 15 \times \frac{I/D}{25}$$

F = Force in Newtons

L = Length of pipework (longest length)

15 = 15 Newtons which is the frictional resistance based on the use of a DST-253 Slide Guide

I/D = Inside diameter of the pipework

Example 1

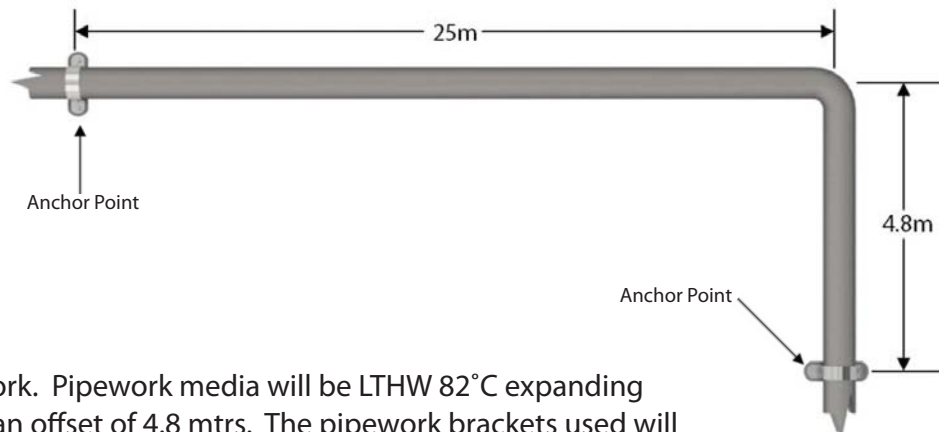

25 mtrs 65NB Steel Pipework. Pipework media will be LTHW 82°C expanding (0.91 x 25) 22.75mm with an offset of 4.8 mtrs. The pipework brackets used will be DST 253 Slide Guides.

$$(A) \quad F = \frac{24IX}{L^3} \quad F = \frac{24 \times 54.5 \times 22.75}{112.68} = 264.08 \text{ Newtons}$$

(B) We also need to add the force to overcome frictional resistance:

$$F = L \times 15 \times \frac{I/D}{25} \quad F = \frac{25 \times 15 \times 65}{25} = 937.5 \text{ Newtons}$$

Therefore the total anchor load will be:

$$(A) = 264.08 + (B) = 937.50 = 1201.58 \text{ Newtons}$$

Example 2

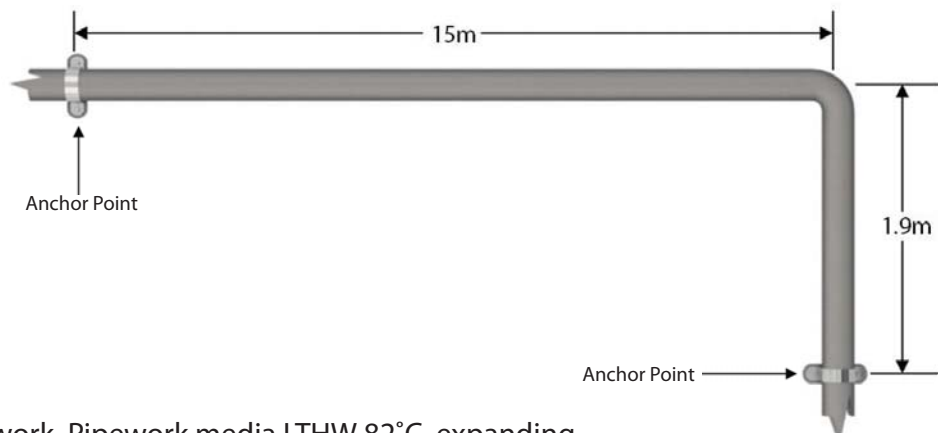

42cu (table Y) copper pipework. Pipework media LTHW 82°C. expanding (1.37 x 15) = 20.55mm The pipework brackets used will be DST Group Ltd Surefix UL pipe clip + DST Ballhanger.

$$(A) \quad F = \frac{8.4IX}{L^3} \quad F = \frac{8.4 \times 3.93 \times 20.55}{6.86} = 98.89 \text{ Newtons}$$

(B) We also need to add the force to overcome frictional resistance.

$$F = L \times 30 \times \frac{I/D}{25} \quad F = \frac{15 \times 30 \times 42}{25} = 675.00 \text{ Newtons}$$

Therefore the total anchor load will be:

$$(A)=98.89 + (B) = 675.00 = 773.89 \text{ Newtons}$$

Pipework & Expansion Guide

Flexibility of a Pipe with Offset

If natural offsets occur within the design of the pipework system, it may be possible to utilise this to take up thermal expansion by using the natural flexibility of the pipework. The tables below show the minimum length of offset required for steel and copper pipes subjected to thermal expansion.

A system utilising an offset to take up expansion can be bracketed utilising most common types of brackets including drop rods, sliding and rolling supports. For more information, please see the first section of this product guide for more details.

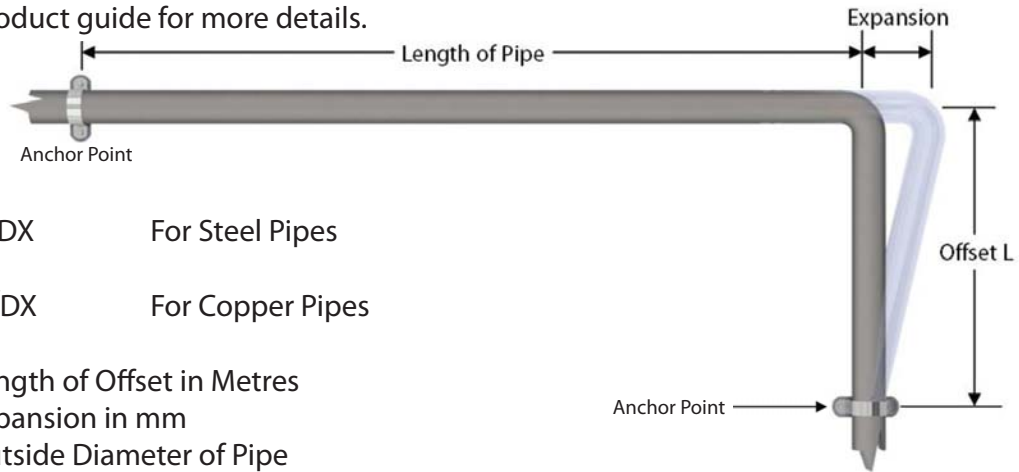

Offset $L = 0.1 \sqrt{DX}$ For Steel Pipes

Offset $L = 0.06 \sqrt{DX}$ For Copper Pipes

- L = Length of Offset in Metres
- X = Expansion in mm
- D = Outside Diameter of Pipe

Table Showing Single Offset For Steel Pipes (Without cold draw)

Expansion X	Pipe Nominal Bore											
	15nb	20nb	25nb	32nb	40nb	50nb	65nb	80nb	100nb	125nb	150nb	200nb
1mm	0.46	0.52	0.58	0.65	0.69	0.77	0.87	0.94	1.09	1.18	1.29	1.48
3mm	0.79	0.90	1.01	1.12	1.20	1.34	1.51	1.63	1.84	2.05	2.24	2.57
5mm	1.02	1.16	1.30	1.45	1.55	1.73	1.95	2.11	2.39	2.65	2.89	3.32
10mm	1.45	1.64	1.84	2.04	2.19	2.44	2.75	2.98	3.38	3.74	4.09	4.69
15mm	1.77	2.01	2.25	2.51	2.68	3.00	3.38	3.65	4.13	4.58	5.01	5.74
20mm	2.05	2.32	2.61	2.89	3.09	3.46	3.89	4.22	4.77	5.90	5.79	6.63
30mm	2.51	2.84	3.19	3.54	3.79	4.24	4.77	5.16	5.85	6.48	7.09	8.12
40mm	2.89	3.29	3.69	4.09	4.38	4.89	5.51	5.97	6.75	7.48	8.19	9.38
60mm	3.55	4.02	4.02	5.01	5.36	6.00	6.75	7.31	8.27	9.17	10.04	11.49
80mm	4.09	4.65	4.65	5.79	6.19	6.92	7.79	8.43	9.54	10.58	11.59	13.27
100mm	4.58	5.19	5.19	6.48	6.92	7.75	8.71	9.43	10.67	11.83	12.96	14.83

Table Showing Single Offset For Copper Pipes (Without cold draw)

Expansion X	Pipe Nominal Bore											
	15nb	22nb	28nb	35nb	42nb	54nb	67nb	76nb	108nb	133nb	159nb	219nb
1mm	0.23	0.28	0.32	0.35	0.39	0.44	0.49	0.52	0.62	0.69	0.76	0.89
3mm	0.40	0.49	0.55	0.61	0.67	0.76	0.85	0.91	1.08	1.19	1.31	1.54
5mm	0.52	0.63	0.71	0.79	0.87	0.99	1.09	1.17	1.39	1.55	1.69	1.99
10mm	0.73	0.89	1.00	1.12	1.22	1.39	1.55	1.65	1.97	2.19	2.39	2.81
15mm	0.90	1.09	1.23	1.37	1.52	1.71	1.90	2.02	2.41	2.68	2.93	3.44
20mm	1.03	1.26	1.42	1.59	1.74	1.97	2.19	2.34	2.78	3.09	3.38	3.97
30mm	1.28	1.54	1.74	1.94	2.12	2.41	2.69	2.86	3.42	3.79	4.14	4.86
40mm	1.47	1.78	2.01	2.24	2.45	2.79	3.11	3.31	3.98	4.38	4.78	5.62
60mm	1.80	2.18	2.46	2.75	3.01	3.42	3.80	4.05	4.83	5.36	5.86	6.88
80mm	2.07	2.52	2.84	3.17	3.48	3.94	4.39	4.68	5.58	6.19	6.77	7.94
100mm	2.32	2.81	3.17	3.55	3.89	4.41	4.91	5.23	6.24	6.92	7.56	8.88

Example of how cold draw can be used:

30m of 100NB Steel Pipework
 82°C LTHW
 $\Delta = L \times T \times C \text{ of } \Delta$

$$\Delta = 30 \times 82 \times 1.11 = 27.3\text{mm } \Delta$$

27.3mm will require a 5.85m Offset (According to the table on the previous page)

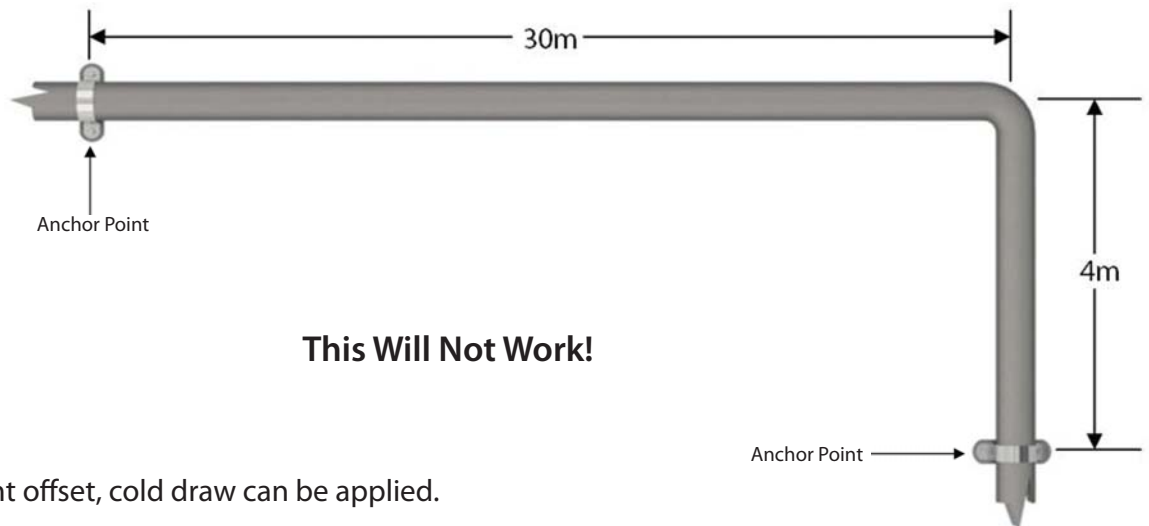

If there is insufficient offset, cold draw can be applied.

Standard practice would be to reduce the length of the pipework or "COLD DRAW" it by 50% of the expected expansion.

Once applied, the pipework is in effect pre-stressed, allowing the offset to take up twice the amount of expansion.

Therefore, if 27.3mm of expansion will require a 5.85m Offset, with 50% cold draw, the expansion is effectively 13.65mm, therefore the offset required will be 3.94m.

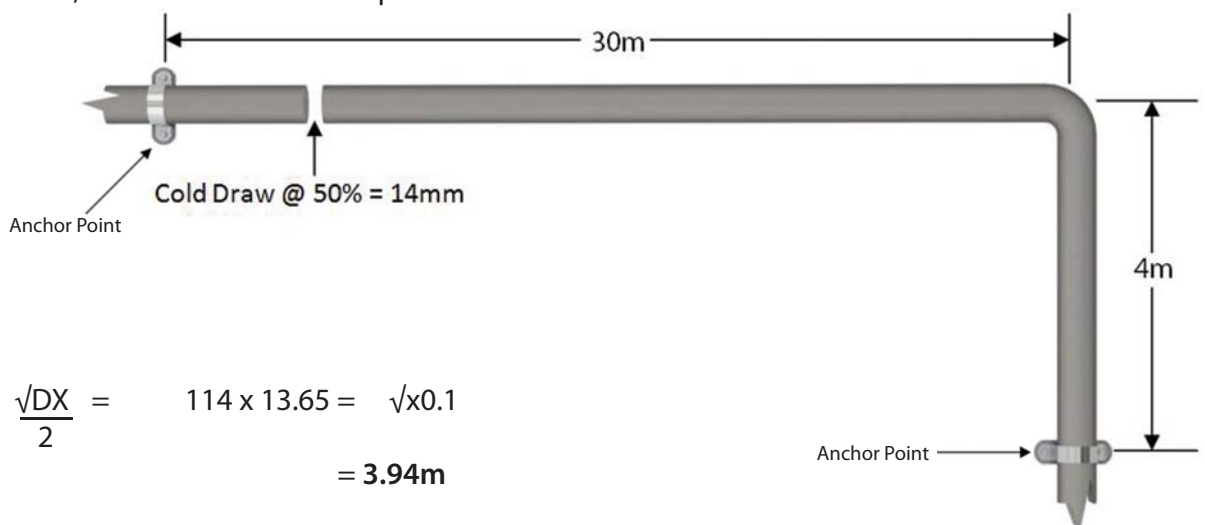

$$\text{Offset } L = 0.1 \frac{\sqrt{DX}}{2} = 114 \times 13.65 = \sqrt{x}0.1 = 3.94\text{m}$$

Pipework & Expansion Guide

Flexibility of Pipe with Loop

If the use of expansion devices is not suitable for the application, you may be able to utilise expansion loops to take up the thermal expansion of the pipework. Loops should always be positioned in the middle of a pipe run, with anchors at each end of the run.

Loops are often useful on a drop rod system as axial expansion devices cannot be used on such a system. If you design a loop into a pipework system, we strongly recommend the use of DST Ball Hangers to aid movement.

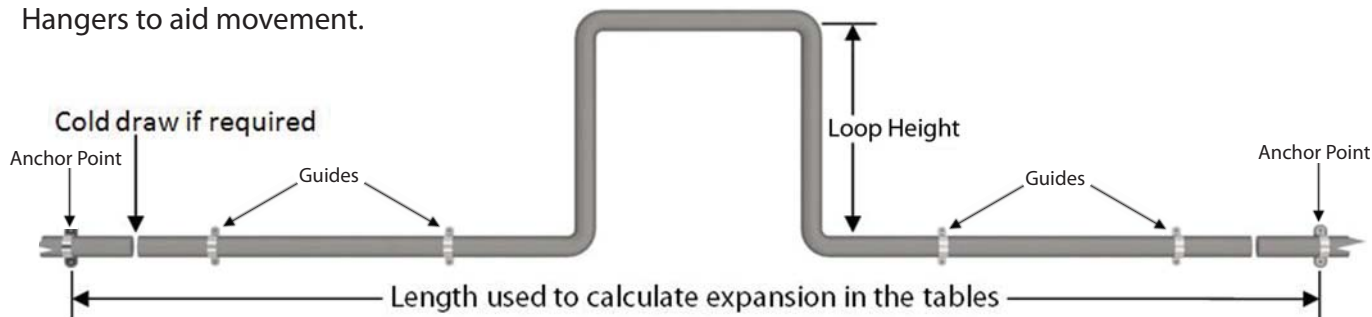

Offset $L = 0.1 \frac{DX}{2}$ For Steel Pipes $L =$ Length of Offset in Metres

$X =$ Expansion in mm
 $D =$ Outside Diameter of Pipe

Offset $L = 0.06 \frac{DX}{2}$ For Copper Pipes

Table Showing Single Offset For Steel Pipes (Without cold draw)

Expansion X	Pipe Nominal Bore											
	15nb	20nb	25nb	32nb	40nb	50nb	65nb	80nb	100nb	125nb	150nb	200nb
1mm	0.32	0.36	0.41	0.46	0.49	0.55	0.62	0.67	0.75	0.84	0.92	1.05
3mm	0.56	0.64	0.71	0.79	0.85	0.95	1.07	1.15	1.31	1.45	1.59	1.82
5mm	0.72	0.82	0.92	1.02	1.09	1.22	1.38	1.49	1.69	1.87	2.05	2.35
10mm	1.02	1.16	1.30	1.45	1.55	1.73	1.94	2.11	2.39	2.65	2.89	3.31
15mm	1.25	1.50	1.59	1.77	1.89	2.12	2.39	2.58	2.92	3.24	3.55	4.06
20mm	1.45	1.64	1.84	2.05	2.19	2.45	2.76	2.98	3.38	3.74	4.09	4.69
30mm	1.77	2.01	2.26	2.51	2.68	3.00	3.38	3.65	4.13	4.58	5.01	5.74
40mm	2.05	2.32	2.61	2.89	3.09	3.46	3.89	4.22	4.77	5.29	5.79	6.63
60mm	2.50	2.84	3.19	3.54	3.79	4.24	4.77	5.17	5.58	6.48	7.09	8.12
80mm	2.89	3.29	3.69	4.09	4.38	4.89	5.11	5.97	6.75	7.48	8.19	9.93
100mm	3.24	3.67	4.12	4.58	4.89	5.48	6.16	6.67	7.54	8.37	9.17	10.48

Table Showing Single Offset For Copper Pipes (Without cold draw)

Expansion X	Pipe Nominal Bore											
	15nb	22nb	28nb	35nb	42nb	54nb	67nb	76nb	108nb	133nb	159nb	219nb
1mm	0.16	0.19	0.22	0.25	0.27	0.31	0.35	0.37	0.44	0.49	0.53	0.63
3mm	0.28	0.34	0.38	0.43	0.48	0.54	0.60	0.64	0.76	0.85	0.92	1.08
5mm	0.56	0.44	0.50	0.56	0.61	0.69	0.77	0.83	0.98	1.09	1.19	1.40
10mm	0.59	0.63	0.71	0.79	0.87	0.98	1.09	1.17	1.39	1.55	1.69	1.98
15mm	0.63	0.77	0.87	0.97	1.06	1.21	1.34	1.43	1.71	1.89	2.07	2.43
20mm	0.73	0.89	1.00	1.12	1.22	1.39	1.55	1.65	1.97	2.19	2.39	2.81
30mm	0.90	1.09	1.23	1.37	1.51	1.71	1.90	2.03	2.41	2.67	2.93	3.43
40mm	1.04	1.26	1.42	1.59	1.73	1.97	2.19	2.34	2.79	3.09	3.38	3.97
60mm	1.27	1.54	1.74	1.94	2.12	2.41	2.69	2.86	3.42	3.79	4.14	4.86
80mm	1.47	1.77	2.01	2.24	2.46	2.78	3.11	3.31	3.94	4.38	4.78	5.62
100mm	1.64	1.99	2.24	2.51	2.75	3.12	3.47	3.69	4.41	4.89	5.35	6.28

Cold draw can be used if the size of the loop cannot be accommodated. The rate of cold draw is normally 50% of the total movement. If the pipework is suspended using drop rods, it would be advisable to use DST Ball Hangers to reduce stresses as the pipework moves.

Drop Rod Calculation Example:

Calculation of Drop Rod Length = $\Delta \times \tan 5^\circ$

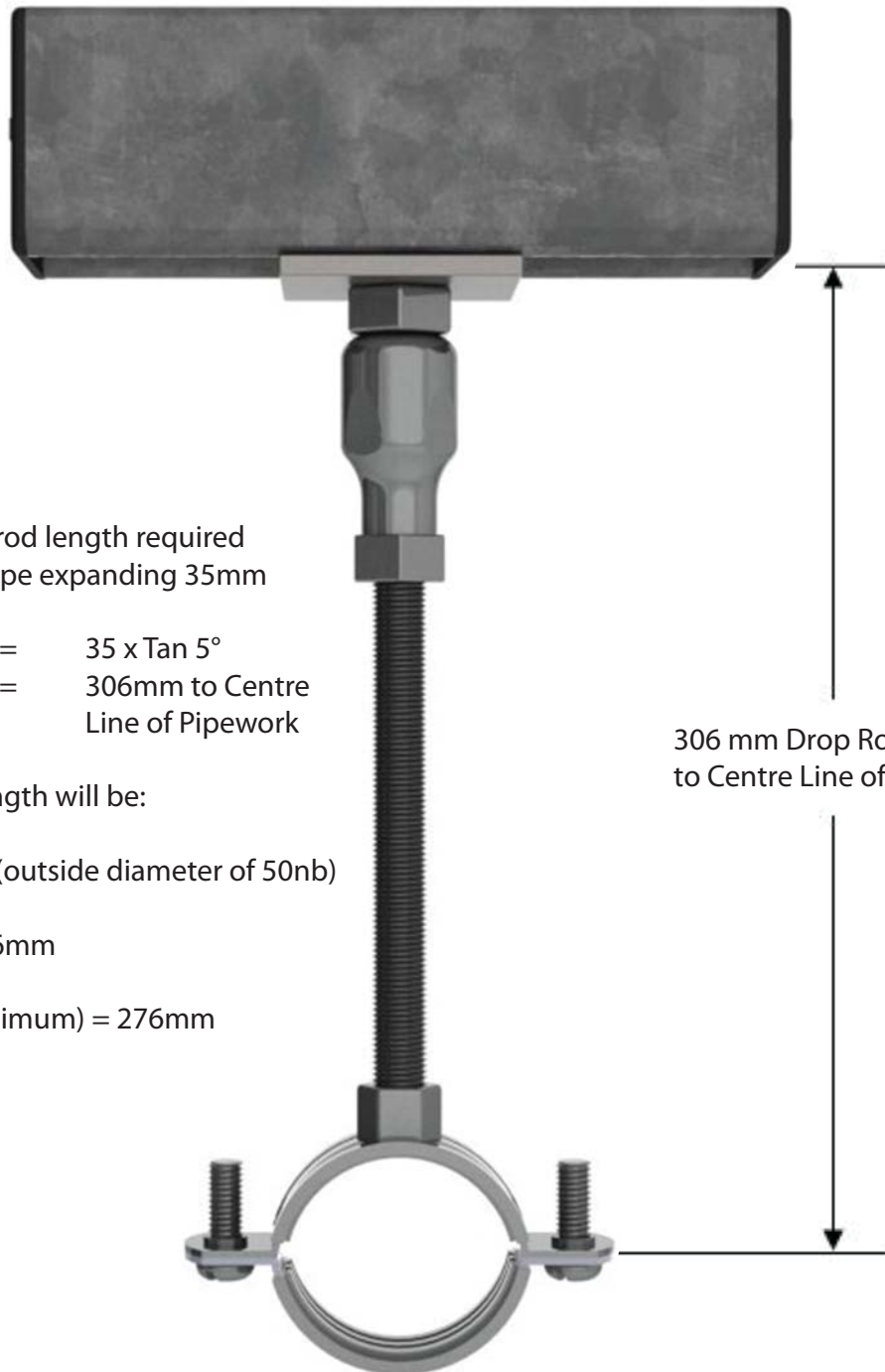

To Calculate the drop rod length required for a length of 50nb pipe expanding 35mm

$$\begin{aligned} \text{Expansion in mm} &= 35 \times \tan 5^\circ \\ &= 306\text{mm to Centre Line of Pipework} \end{aligned}$$

Therefore drop rod length will be:

$$306\text{mm} - \frac{1}{2} \text{ of } 60\text{mm (outside diameter of 50nb)}$$

$$306\text{mm} - 30\text{mm} = 276\text{mm}$$

$$\text{Drop Rod Length (minimum)} = 276\text{mm}$$

306 mm Drop Rod Length to Centre Line of Pipework

If the drop rod length required is too long for the installation, DST Ball Hangers or DST Hemispherical Cups and Washers can be used to increase the movement, but decrease the drop rod length. Further advice can be given by one of our Technical Sales Engineers.

Pipework & Expansion Guide

Pipe Anchors using Expansion Bellows

■ Pipe Anchors for AX1, AX2 and AX3 Expansion Compensators

Pipe anchors are needed to overcome the forces set up when axial bellows and under pressure. The following conditions can exist:

Pipeline under test pressure

Pipeline under working pressure and temperature

Each condition must be investigated:

- Pipeline under test pressure - this force is made up of test pressure multiplied by the effective area.
- Pipeline under working pressure and temperature - the force is made up of three components;
 - a. The force to overcome internal pressure; i.e working pressure multiplied by effective area.
 - b. The force to compress the expansion joint . This is calculated by using the force to compress in Newtons/mm.
 - c. The force to overcome the friction of pipe movement, which can be estimated at 30N per metre of pipeline for each 25mm of pipe diameter. This assumes about the worst possible condition of face to face sliding supports. Coefficient of friction about 0.4. If hangers or rollers are used, reduce the figure of 15N per metre of pipeline.

Thus the Total Force = a + b + c

Expansion joints should not be removed during a pressure test. The purpose of a pressure test is to put the pipeline under stresses greater than those which occur under working conditions. If the expansion joints are removed the anchors and guides are not subjected to any stresses and therefore faults in their design will not show up.

When positioning anchors, great care should be taken to ensure that the main structure to which the anchor is attached, is in fact strong enough to withstand the forces transmitted by the anchor. Also ensure that when a number of pipes are anchored at one point, the total force under working conditions is considered.

Bellow is an example showing the anchor forces set up under different conditions.

In these examples 1bar = 100kN/m²

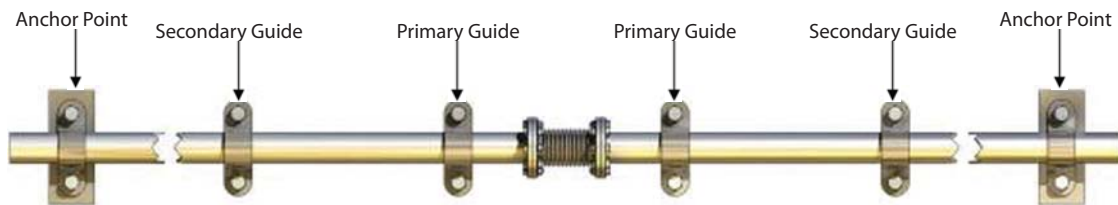

Calculate the anchor force for a 25m long pipeline of 32mm NB at 6 bar working pressure and temperature of 82°C, using modular slide guides.

At 82°C the expansion in mm/metre is 1.0

Therefore the total expansion is 1.0 x 25 = 25mm

Test pressure is 1.5 x working pressure = 1.5 x 6 = 9 bar (=900 kN/m²)

Effective area can be taken from the product catalogue, in this case = 16cm²

For a pipeline under the test conditions, TOTAL FORCE = test pressure x effective area = 900 x 16 x 0.1 = 1,440 N

Working Pressure of 6 (=600 kN/m²)

For a pipeline under working conditions, TOTAL FORCE = a + b + c

a = 600 x 16 x 0.1 = 960 N

b = 15 x 25 = 375N

c = 15 x 25 x $\frac{32}{25}$ = 480 N

therefore, TOTAL FORCE = 960 + 375 + 480 = 1,815N

Pipe Anchors Using Lateral/Angular Expansion Compensators FA1, FA2, AN1, AN2, GI1, GI2

It is preferable to install the above type of Expansion Compensators if the engineer has concerns over Anchor Loads. The Anchor Loads created by the use of these units are significantly lower than the load created by using an Axial Expansion Compensator.

Anchor Loads using Lateral / Angular Expansion Compensators are created from Two Fields.

1. The Force To Deflect The Expansion Compensator.
2. The Force Created Due to Frictional Resistance.

Example

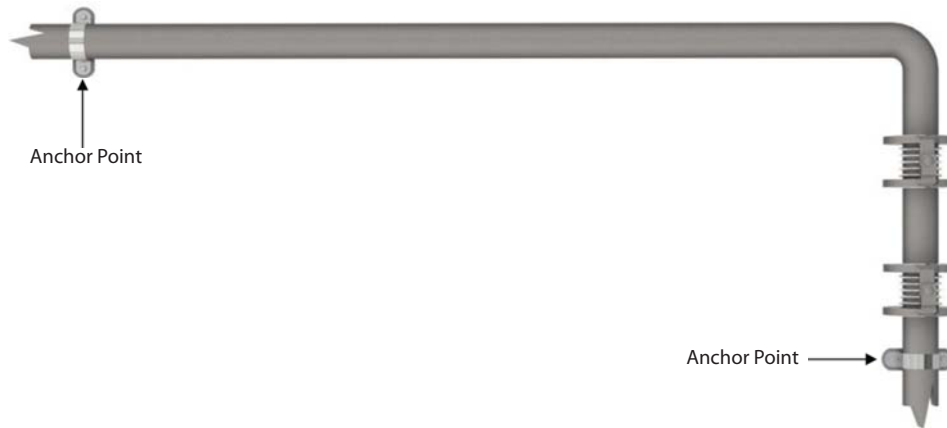

1. The Force To Deflect. This information can be found earlier in this guide for DST Type DST/AN1/PN16. In this case 100mm it will be:
 Force to Deflect Each Expansion Compensator = $98 \text{ N / deg} \times 2$
 = 196.00 Newtons
2. Force To Overcome Friction. In this example we will be bracketing using DST 114 Roller Chair and Guide, which has a frictional resistance of 30 Newtons.

$$\text{Force To Overcome Frictional Resistance} = 15 \times 90 \times \frac{100}{25} = 5400 \text{ Newtons}$$

Therefore The total Anchor Force Will Be:

$$1 = 196 \text{ Newtons} \quad + \quad 2 = 5400 \text{ Newtons}$$

$$\text{Anchor Load Total} = 5596 \text{ Newtons}$$

As you can see the majority of the Anchor Load is made up from the frictional resistance of pipework bracketry. It is advisable to use Pipework Bracketry which has a low frictional resistance such as a DST 253 Slide Guide. Please seek further advise from our technical sales team on frictional resistance and futher Pipework Bracketry.

These types of Expansion Compensators are can be used on a Drop Rod system.



DST 102 - Saddle Guide



DST 114 - Roller Chair Guide



DST LF1, LF2 & LF3
Low Friction Slide Guide



DST 132 - Nylon Coated Saddle
Guide C/W Polypropolene Strip



DST240 (O) - Oversized Brass
Munsen Ring



DST MS1 & MS2
Modular Slide Guide



DST 253G - PTFE Slide Guide
Bracket



DST 253S - PTFE Skid Bracket

Pipework & Expansion Guide

Flange Data Table

Nominal Size	Flange Table	Outer Ø	Nº of Bolt Holes	Bolt Hole Ø	Bolt Circle (P.C.D)	Nominal Size	Flange Table	Outer Ø	Nº of Bolt Holes	Bolt Hole Ø	Bolt Circle (P.C.D)	Key:
15mm 1/2"	E	95	4	14	67	80 mm 3"	E	184	4	18	146	E = BS10 Table 'E'
	F	95	4	14	67		F	203	8	18	165	F = BS10 Table 'F'
	H	114	4	18	83		H	203	8	18	165	H = BS10 Table 'H'
	150	89	4	16	60		150	191	4	19	152	150 = BS1560 Class 150, ASA 150, ANSI B16.5 Class 150
	300	95	4	16	67		300	210	8	22	168	300 = BS1560 Class 300, ASA 300, ANSI BS16.5 Class 300
	6	80	4	11	55		6	190	4	18	150	6 = BS4504 PN6, DIN2501 PN6
	10	95	4	14	65		10	200	8	18	160	10 = BS4504 PN10, DIN2501 PN16
	16	95	4	14	65		16	200	8	18	160	16 = BS4504 PN16, DIN 2501 PN16
20 mm 3/4"	E	101	4	14	73	100 mm 4"	E	216	8	18	178	25 = BS4504 PN25, DIN2501 PN25
	F	101	4	14	73		F	229	8	18	191	
	H	114	4	18	83		H	229	8	18	191	
	150	98	4	16	70		150	229	8	19	191	
	300	117	4	19	83		300	254	8	22	200	
	6	90	4	11	65		6	210	4	18	170	
	10	105	4	14	75		10	220	8	18	180	
	16	105	4	14	75		16	220	8	18	180	
25 mm 1"	E	115	4	14	83	125 mm 6"	E	254	8	18	210	
	F	121	4	18	87		F	279	8	22	235	
	H	121	4	18	87		H	279	8	22	235	
	150	108	4	16	79		150	254	8	22	216	
	300	124	4	19	89		300	279	8	22	235	
	6	100	4	11	75		6	240	8	18	200	
	10	115	4	14	85		10	250	8	18	210	
	16	115	4	14	85		16	250	8	18	210	
32 mm 1 1/4"	E	121	4	14	87	150 mm 6"	E	279	8	22	235	
	F	133	4	18	98		F	305	12	22	260	
	H	133	4	18	98		H	305	12	22	260	
	150	117	4	16	89		150	279	8	22	241	
	300	133	4	19	98		300	318	12	22	270	
	6	120	4	14	90		6	265	8	18	225	
	10	140	4	18	100		10	285	8	22	240	
	16	140	4	18	100		16	285	8	22	240	
40 mm 1 1/2"	E	121	4	14	98	200 mm 8"	E	337	8	22	292	
	F	133	4	18	105		F	368	12	22	324	
	H	133	4	18	105		H	368	12	22	324	
	150	117	4	16	98		150	343	8	22	298	
	300	133	4	22	114		300	381	12	25	330	
	6	120	4	14	100		6	320	8	18	280	
	10	140	4	18	110		10	340	8	22	295	
	16	140	4	18	110		16	340	12	22	295	
50 mm 2"	E	152	4	18	114	250 mm 10"	E	406	12	22	356	
	F	165	4	18	127		F	432	12	25	381	
	H	165	4	18	127		H	432	12	25	381	
	150	152	4	19	121		150	406	12	25	362	
	300	165	8	19	127		300	444	12	29	387	
	6	140	4	14	110		6	375	12	18	335	
	10	165	4	18	125		10	395	12	22	350	
	16	165	4	18	125		16	405	12	26	355	
65 mm 2 1/2"	E	165	4	18	127	300 mm 12"	E	457	12	25	406	
	F	184	8	18	146		F	489	16	25	438	
	H	184	8	18	146		H	489	16	25	438	
	150	178	4	19	140		150	482	12	25	432	
	300	191	8	22	149		300	521	16	32	451	
	6	160	4	14	130		6	440	12	22	395	
	10	185	4	18	145		10	445	12	22	400	
	16	185	4	18	145		16	460	12	26	410	
	25	185	8	18	145	25	485	16	30	430		

Pipework & Expansion Guide

Useful Conversion Factors

Pressure Units

Symbol	Description	Bar	kPA	kN/m ²	psi	atm	m wg
1 bar	Bar		100.0	100.0	14.5037	0.9869	10.1972
1 kPa	Kilopascal	0.01		1.0	0.145	0.0099	0.102
1 kN/m ²	Kilonewton per square metre	0.01	1.0		0.145	0.0099	0.102
1 psi	Pound per square inch	0.0689	6.8948	6.8948		0.0681	0.07031
1 atm	Atmosphere	1.0133	101.3250	101.3250	14.696		10.3323
1 m wg	Metre water gauge	0.0981	9.8067	9.8067	1.422	0.0968	

Vacuum Units

Symbol	Description	mm	Hg in Hg	psi	Torr	bar	atm
1mm Hg	Millimetre of mercury		0.0394	0.49	1.0	0.0013	0.0013
1 in Hg	Inch of mercury	25.4		0.019	25.4	0.00338	0.0334
1 psi	Pound per square inch	51.7	2.04		51.7	0.0689	0.0681
1 Torr	Torr	1.0	0.0394	0.49		0.0013	0.0013
1 bar	Bar	750	29.53	14.5037	750		0.9869
1 atm	Atmosphere	760	29.92	14.696	760	1.0133	

Linear Units

Symbol	Description	mm	cm	m	in	ft	yd
1 mm	Millimetre		0.1	0.001	0.0394	0.0033	0.0011
1 cm	Centimetre	10		0.1	0.3937	0.0328	0.0109
1 m	Metre	1000	100		39.3701	3.2808	1.0936
1 in	Inch	25.4	2.54	0.0254		0.0833	0.0278
1 ft	Foot	304.8	30.48	0.3048	12		0.3333
1 yd	Yard	914.4	91.44	0.9144	36	3	

Weight Units

Symbol	Description	g	kg	t	oz	lb	tn
1 g	Gramme		0.001	0.000001	0.036	0.0022	0.0000098
1 kg	Kilogramme	1000		0.001	36.413	2.2047	0.0009843
1 t	Tonne (metric)	1000000	1000		36413.44	2204.7222	0.984251
1 oz	Ounce	28.4	0.0284	0.0000284		0.0625	0.0000279
1 lb	Pound	453.6	0.4536	0.0004536	16		10.0004465
1 tn	Ton (imperial)	1016000	1016	1.016	35840	2240	

Temperature Units

Symbol	Description	°C	°F	°K
°C	Degree Celsius		Times 1.8, plus 32	Plus 273.16
°F	Degree Farenheit	Minus 32 divide 1.8		Divide 1.8 plus 255.38
°K	Degree Kelvin	Minus 273.16	Minus 255.38	

Pipework & Expansion Guide

Pipe Data Table

Nominal Size	Material	Wall Thickness	Max O/D	Min O/D	Mean I/D	Int Cross Section Area	Metal Cross Section Area	Surface Area	Moment of Inertia	Section Modulus	Pipe Weight	Water Content
		mm	mm	mm	mm	mm ²	mm ²	m ²	cm ⁴	cm ³	kg/m	l/m
15 mm	Heavy Steel	3.25	21.7	21.1	14.9	175	186	0.067	0.79	0.736	1.45	0.175
	Medium Steel	2.65	31.7	21.1	16.2	205	155	0.067	0.71	0.656	1.22	0.250
1/2"	Copper (Table X)	0.70	15.045	14.965	13.6	145	31.6	0.047	0.08	0.108	0.28	0.145
	Copper (Table Y)	1.00	15.045	14.965	13.0	133	44.1	0.047	0.11	0.145	0.39	0.133
15 mm	Copper (Table Z)	0.50	15.045	14.965	14.0	154	22.9	0.047	0.06	0.080	0.20	0.154
20 mm	Heavy Steel	3.25	27.2	26.6	20.4	326	243	0.085	1.75	1.29	1.90	0.326
	Medium Steel	2.65	27.2	26.6	21.6	367	203	0.085	1.50	1.11	1.58	0.367
3/4"	Copper (Table X)	0.90	22.055	21.975	20.2	321	59.6	0.069	0.33	0.303	0.52	0.321
	Copper (Table Y)	1.20	22.055	21.975	19.6	302	78.3	0.069	0.43	0.387	0.69	0.302
22 mm	Copper (Table Z)	0.60	22.055	21.975	20.8	340	40.2	0.069	0.23	0.210	0.35	0.340
25mm	Heavy Steel	4.05	34.2	33.4	25.7	518	380	0.106	4.29	2.54	2.97	0.518
	Medium Steel	3.25	34.2	33.4	27.3	586	312	0.106	3.70	2.20	2.44	0.586
1"	Copper (Table X)	0.90	28.055	27.975	26.2	540	76.7	0.085	0.71	0.504	0.68	0.540
	Copper (Table Y)	1.20	28.055	27.975	25.6	516	101	0.085	0.91	0.650	0.89	0.516
28 mm	Copper (Table Z)	0.60	28.055	27.975	26.83	565	51.7	0.085	0.49	0.347	0.46	0.565
32 mm	Heavy Steel	4.05	42.9	42.1	34.3	927	490	0.134	9.16	4.31	3.84	0.926
	Medium Steel	3.25	42.9	42.1	35.9	1016	461	0.134	7.74	3.64	3.14	1.016
1 1/4"	Copper (Table X)	0.90	35.07	34.99	32.6	837	128	0.110	1.83	1.043	1.12	0.837
	Copper (Table Y)	1.20	35.07	34.99	32.0	806	158	0.110	2.22	1.270	1.39	0.806
35 mm	Copper (Table Z)	0.70	35.07	34.99	33.6	889	75.5	0.110	1.11	0.635	0.67	0.889
40 mm	Heavy Steel	4.05	48.8	48.0	40.2	1272	566	0.152	13.98	5.79	4.43	1.271
	Medium Steel	3.25	48.8	48.0	41.9	1376	461	0.152	11.78	4.87	3.61	1.376
1 1/2"	Copper (Table X)	1.20	42.07	41.99	39.6	1234	154	0.132	3.21	1.528	1.36	1.234
	Copper (Table Y)	1.50	42.07	41.99	39.0	1197	191	0.132	3.93	1.869	1.69	1.197
42 mm	Copper (Table Z)	0.80	42.07	41.99	40.4	1284	104	0.132	2.20	1.048	0.91	1.284
50 mm	Heavy Steel	4.50	60.8	59.8	51.3	2070	784	0.189	30.8	10.2	6.17	2.070
	Medium Steel	3.65	60.8	59.8	53.0	2205	651	0.189	26.2	8.7	5.10	2.205
2"	Copper (Table X)	1.20	54.07	53.99	51.6	2095	199	0.170	7.0	2.573	1.76	2.095
	Copper (Table Y)	2.00	54.07	53.99	50.0	1965	327	0.170	11.1	4.101	2.88	1.965
54 mm	Copper (Table Z)	0.90	54.07	53.99	52.2	2145	150	0.170	5.3	1.963	1.33	2.145
65 mm	Heavy Steel	4.50	76.6	75.4	67.00	3530	1005	0.239	64.5	170	7.90	3.530
	Medium Steel	3.65	76.6	75.4	68.7	3700	831	0.239	54.5	14.3	6.51	3.700
2 1/2"	Copper (Table X)	1.20	66.75	66.60	64.3	3245	247	0.209	13.2	3.97	2.18	3.245
	Copper (Table Y)	2.00	66.75	66.60	63.1	3125	406	0.209	21.3	6.38	3.58	3.125
67 mm	Copper (Table Z)	1.00	66.75	66.60	64.7	3285	206	0.209	11.1	3.34	1.82	3.285
80 mm	Heavy Steel	4.85	89.5	88.1	79.0	4905	1285	0.279	114	25.6	10.1	4.905
	Medium Steel	4.05	89.5	88.1	80.7	5115	1080	0.279	97.0	21.8	8.47	5.115
3"	Copper (Table X)	1.50	76.3	76.15	73.2	4210	352	0.239	24.4	6.45	3.11	4.210
	Copper (Table Y)	2.00	76.3	76.15	72.2	4100	467	0.239	31.9	8.43	4.11	4.100
76 mm	Copper (Table Z)	1.20	76.3	76.15	73.8	4280	283	0.239	19.9	5.22	2.50	4.280
100 mm	Heavy Steel	5.40	114.9	113.3	103.3	8380	1840	0.358	272	47.7	14.4	8.380
	Medium Steel	4.50	114.9	113.3	105.1	8680	1540	0.358	231	40.6	12.1	8.680
4"	Copper (Table X)	1.50	108.25	108.0	105.1	8680	504	0.340	71.4	13.21	4.45	8.680
	Copper (Table Y)	2.00	108.25	108.0	103.1	8355	832	0.340	115	21.41	7.33	8.355
108 mm	Copper (Table Z)	1.20	108.25	108.0	105.7	8780	405	0.340	71.2	10.66	3.57	8.780
125 mm	Heavy Steel	5.40	140.6	138.7	127.7	13050	2270	0.438	520	73.4	17.8	13.05
	Medium Steel	4.85	140.6	138.7	129.8	13250	2065	0.438	470	67.4	16.2	13.25
5"	Copper (Table X)	1.50	133.5	133.25	130.4	13350	621	0.419	134	20.26	5.47	13.35
	Copper (Table Y)	1.50	133.5	133.25	130.4	13350	621	0.419	134	20.26	5.47	13.35
133 mm	Copper (Table Z)	1.50	133.5	133.25	130.4	13350	621	0.419	134	20.26	5.47	13.35
150 mm	Heavy Steel	5.40	166.1	164.1	154.3	18700	2700	0.518	862	105	21.2	18.70
	Medium Steel	4.85	166.1	164.1	155.3	18950	2065	0.518	787	95.4	19.2	18.95
6"	Copper (Table X)	2.00	159.5	159.25	155.4	18950	988	0.501	304	38.42	8.71	18.95
	Copper (Table Y)	2.00	159.5	159.25	155.4	18950	988	0.501	304	38.42	8.71	18.95
159 mm	Copper (Table Z)	1.50	159.5	159.25	156.4	19200	743	0.501	203	29.09	6.55	19.20
200 mm	Steel	4.88			209.3	34400	3280	0.689	1880	172	25.9	34.42
250 mm	Steel	6.35			260.4	53250	5320	0.859	4745	347	42.0	53.24
300 mm	Steel	7.14			309.6	75300	7080	1.018	8865	547	55.8	75.30

Pipework & Expansion Guide

Support Centres - Data Table

Support Spacing - Space Supports as Table						
Pipe Bore (mm) Nominal	Maximum Support Spacing (m)					
	Steel Pipe		Copper Pipe		Iron Pipe	
	Horizontal	Vertical	Horizontal	Vertical	Horizontal	Vertical
Up to 15	1.8	2.4	1.2	1.8	-	-
20	2.4	3.0	1.4	2.1	-	-
25	2.4	3.0	1.8	2.4	-	-
32	2.7	3.0	2.4	3.0	-	-
40	3.0	3.6	2.4	3.0	-	-
50	3.0	3.6	2.7	3.0	1.8	1.8
65	3.7	4.6	3.0	3.6	-	-
80	3.7	4.6	3.0	3.6	2.7	2.7
100	3.7	4.6	3.0	3.6	2.7	2.7
125	3.7	5.4	3.0	3.6	-	-
150	4.5	5.4	3.6	4.2	3.7	3.7
200	5.0	6.0	-	-	3.7	3.7
250	5.0	6.0	-	-	4.5	5.4
300	6.1	10.0	-	-	8.0	10.0
350	10.0	12.0	-	-	-	-
400	10.5	12.6	-	-	-	-
450	11.0	13.2	-	-	-	-
500	12.0	14.4	-	-	-	-
600	14.0	16.8	-	-	-	-

Pipe Bore (mm) Nominal	Maximum Support Spacing (m)					
	UPVC Pipe		PE Pipe		Glass Pipe	
	Class O,B,C Horizontal	Class D,E,6,7 Vertical	Type 32 Horizontal	Type 50 Vertical	Horizontal	Vertical
Up to 10	-	0.6	0.3	0.45	-	-
15	-	0.6	0.4	0.6	-	-
20	-	0.65	0.4	0.6	-	-
25	-	0.75	0.4	0.6	-	-
32	-	0.8	0.45	0.7	-	-
40	-	0.9	0.45	0.7	0.9	1.7
50	1.1	1.2	0.55	0.85	1.2	1.7
65	1.2	1.4	0.55	0.85	-	-
80	1.4	1.5	0.6	0.9	1.2	1.7
100	1.5	1.7	0.7	1.1	1.2	1.7
125	1.7	1.9	-	-	-	-
150	1.8	2.1	-	1.3	1.2	1.7
175	2.0	2.3	-	-	-	-
200	2.1	2.5	-	-	-	-
225	2.3	2.7	-	-	-	-
250	2.4	2.9	-	-	-	-
300	2.6	3.1	-	-	-	-
350	2.9	3.4	-	-	-	-
400	3.1	3.7	-	-	-	-
450	3.4	3.7	-	-	-	-

