



DST Group Ltd  
Product Brochure



Tel: +44 (0) 1524 389 494  
[www.dstgroup.co.uk](http://www.dstgroup.co.uk)

Fax: +44 (0) 1524 389 495  
[sales@dstgroup.co.uk](mailto:sales@dstgroup.co.uk)



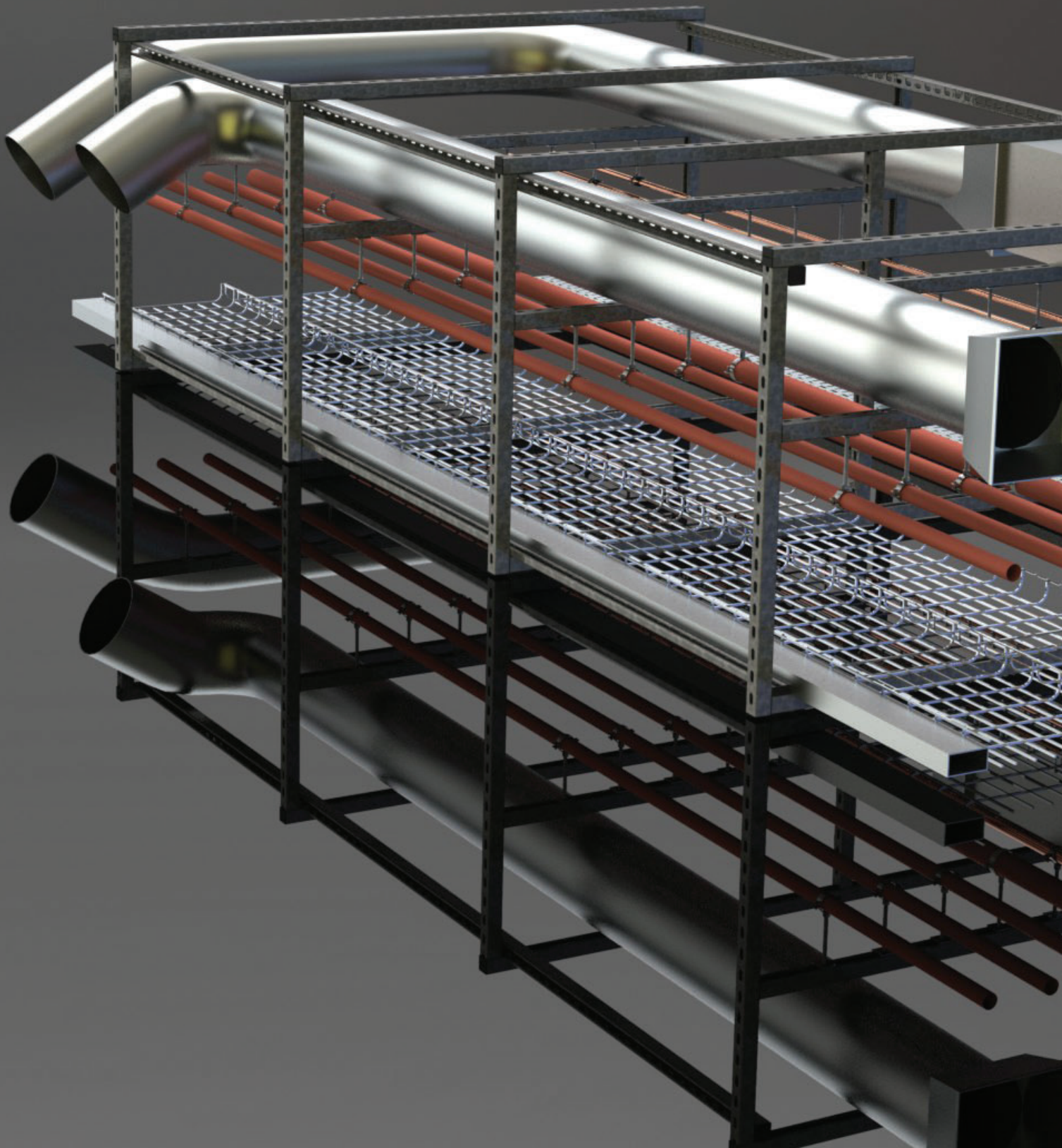

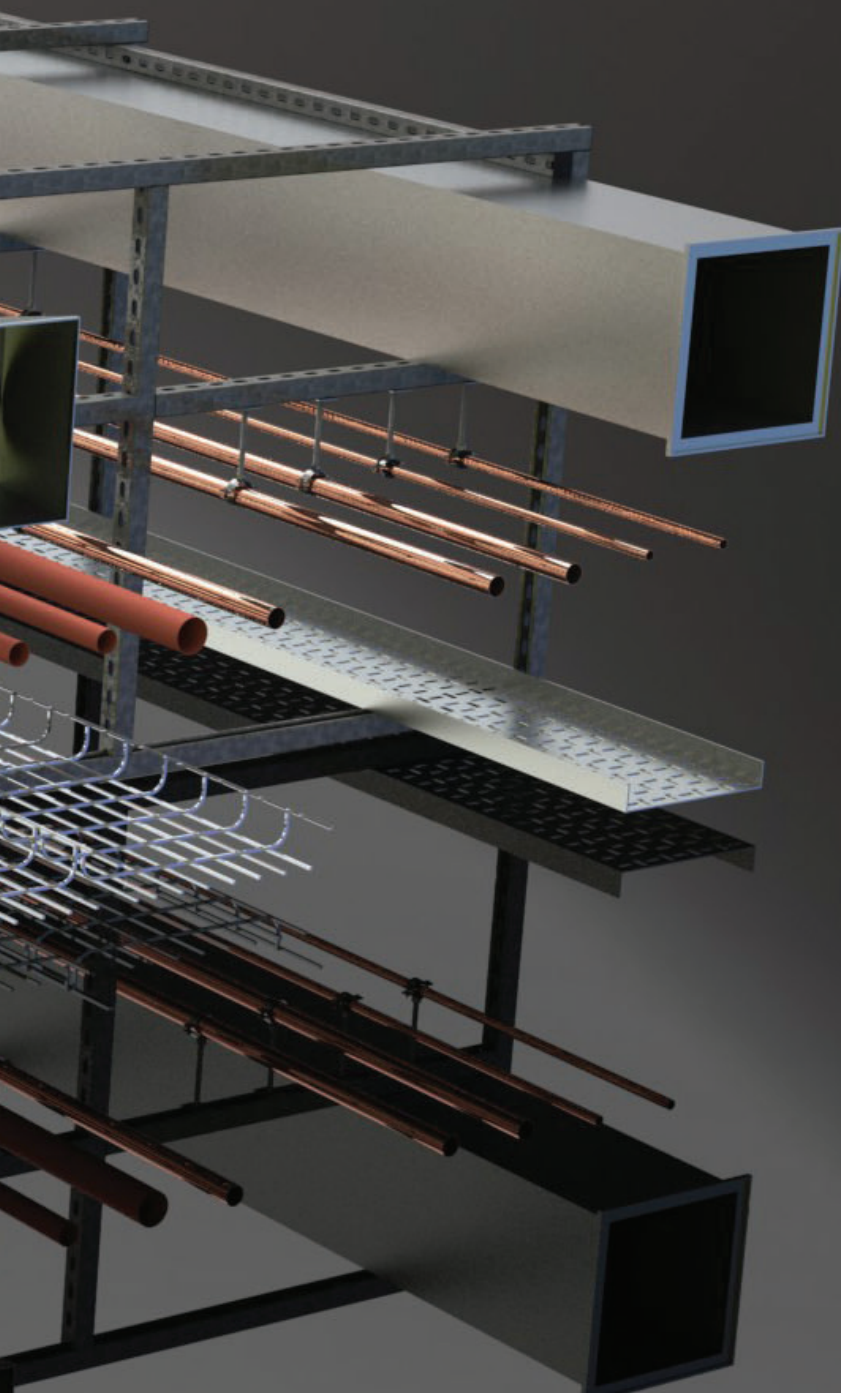

Since its opening in 1993 DST Group Ltd has been committed to providing quality products and services, professional technical support and the highest level of customer service.

DST Group Ltd is one of the leading manufacturers and distributors of engineering equipment in the UK today. Our diverse range of products include:

1. Brackets & Pipe Support Systems
2. Expansion & Anti-vibration Equipment
3. Pre-Assembled Brackets & Pipe Supports
4. Passive Fire Protection
5. Air & Dirt Removal Equipment
6. Secondary Steelwork

Based upon a firm technical background, our engineers can help, advise and design solutions to many aspects of site installation. We can offer stress analysis of steelwork and pipework systems. In September 2004 we moved to our new 19,000 square foot warehouse and distribution centre in Morecambe, housing in excess of 1500 tonnes of stock. From this location we can supply equipment from stock on a next day service anywhere within mainland UK.

In addition we have a purpose built 10,000 square foot manufacturing unit that is the hub of our pre-fabrication operation. The pre-fabrication department can help, advise and manufacture pipework supports, steelwork and vibration isolation to customer requirements.

In May 2004, DST Group Ltd attained ISO 9001: 2000 Quality Management System and in February 2011, this was extended to include ISO 14001 and 18001 thus offering a totally integrated management system including Health and Safety and Environmental Control.





Mechanical Equipment.....7



Expansion & Anti Vibration.....31



Expansion Guide.....63



# Pipe Support Systems





- 7 Surefix XL Unlined Clip
- 8 Surefix XL Rubber Lined Clip
- 9 Heavy Duty Surefix HD Unlined & Lined Clip
- 10 DST100 - Split Band
- 11 DST130 - Nylon Coated Split Band  
DST190 - Forged Eye Bolt  
DST200 - Link Eye  
DST203 - Bow Nut
- 12 DST105 - Bossed Split Band
- 13 DST 102/103 - Saddle
- 14 DST132/133 - Saddle  
DST170 - Filbow Clamp
- 15 Phenolic Pipe Support
- 16 Hardwood Pipe Support  
Calcium Silicate Insulation
- 17 DST 104 Standard & Extended 'U' Bolt
- 18 Guide Clips  
DST MS1 & 2 Modular Slide Guide Assembly  
DSTBH - Ball Hanger
- 19 DST LF Low Friction Slide Guides
- 20 DSTAAB - Adjustable Anchor Bracket
- 21 DST Slip & Band Anchors
- 22 DST114 Roller & Chair Guide Assembly  
DST115 Hanger Roller
- 23 DST118 Roller Chair  
DST134 S/E 'U' Bolt
- 24 DST240 G/M/B - Munsen Rings  
DST241 G/M/B - School Board Clips  
DST242 G/M/B - Backplates
- 25 Fixings
- 26 DST Strut Systems  
Cantilever Arms  
Square Plate Washers  
Channel Nuts
- 26-27 DST Strut Brackets
- 28 Threaded Rod

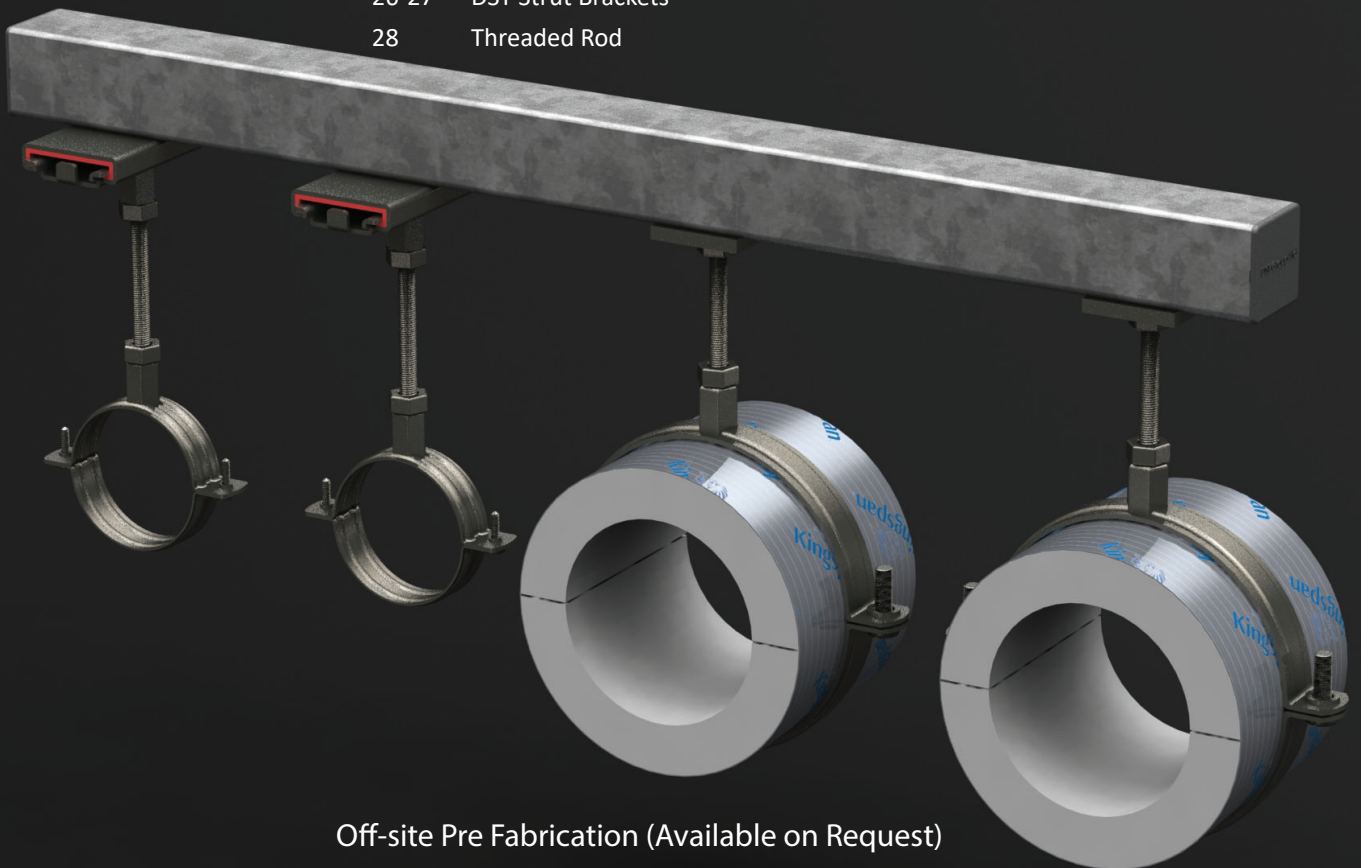

Off-site Pre Fabrication (Available on Request)



## Construction

Mild Steel  
 BZP Finish

## For Use With

Steel & Cast Iron Tubes  
 Insulated Pipe Supports



Pipe Size	Grip Range (mm)	Boss Type	Screw (mm)	Material (mm)
1/2"	19-23	M8/M10	M5 x 25	1 x 20
22mm	23-28	M8/M10	M5 x 25	1 x 20
3/4"	26-25	M8/M10	M5 x 25	1 x 20
1"	32-35	M8/M10	M5 x 25	1 x 20
1 1/4"	39-43	M8/M10	M5 x 25	1 x 20
1 1/2"	45-51	M8/M10	M5 x 25	1.2 x 20
55mm	54-58	M8/M10	M5 x 25	1.2 x 20
2"	60-65	M8/M10	M5 x 25	1.2 x 20
70mm	67-71	M8/M10	M5 x 25	1.2 x 20
2 1/2"	74-82	M8/M10	M6 x 30	1.5 x 25
85mm	82-89	M8/M10	M6 x 30	1.5 x 25
3"	91-98	M8/M10	M6 x 30	1.5 x 25
95mm	93-101	M8/M10	M6 x 30	1.5 x 25
105mm	102-109	M8/M10	M6 x 30	1.5 x 25
4"	109-117	M8/M10	M6 x 30	1.5 x 25
120mm	116-125	M8/M10	M6 x 30	1.5 x 25
125mm	129-141	M8/M10	M6 x 30	2 x 25
5"	136-146	M8/M10	M6 x 30	2 x 25
145mm	142-154	M8/M10	M6 x 30	2 x 25
6"	158-169	M8/M10	M6 x 30	2 x 25
175mm	166-177	M8/M10	M6 x 30	2 x 25

# Surefix XL Rubber Lined Clip

For Copper, Plastic and Stainless Steel Pipes

Created on: 15 Oct 2018  
Version: 1.01  
Last Updated: 14 Apr 2020



## Construction

Mild Steel  
BZP Finish

## For Use With

Copper & Plastic Tubes

## Special Features

Rubber Lining tested to  
DIN4109 for Acoustic Use

Pipe Size	Grip Range (mm)	Boss Type	Screw (mm)	Material (mm)
15cu	13-20	M8/M10	M5 x 25	1 x 20
18mm	17-23	M8/M10	M5 x 25	1 x 20
22cu	21-26	M8/M10	M5 x 25	1 x 20
28cu	26-25	M8/M10	M5 x 25	1 x 20
35cu	33-37	M8/M10	M5 x 25	1 x 20
42cu	40-46	M8/M10	M5 x 25	1.2 x 20
1 1/2"	48-53	M8/M10	M5 x 25	1.2 x 20
54cu	53-59	M8/M10	M5 x 25	1.2 x 20
2"	60-66	M8/M10	M5 x 25	1.2 x 20
67cu	67-77	M8/M10	M6 x 30	1.5 x 25
76cu	75-84	M8/M10	M6 x 30	1.5 x 25
3"	87-96	M8/M10	M6 x 30	1.5 x 25
95mm	94-104	M8/M10	M6 x 30	1.5 x 25
108cu	102-111	M8/M10	M6 x 30	1.5 x 25
4"	109-119	M8/M10	M6 x 30	1.5 x 25
120cu	122-135	M8/M10	M6 x 30	2 x 25
133cu	128-139	M8/M10	M6 x 30	2 x 25
5"	135-148	M8/M10	M6 x 30	2 x 25
159cu	151-164	M8/M10	M6 x 30	2 x 25
6"	158-170	M8/M10	M6 x 30	2 x 25



## Construction

Mild Steel  
 BZP Finish

## For Use With

Steel & Cast Iron Tubes  
 Insulated Pipe Supports



Pipe Size	Grip Range (mm)	Boss Type	Screw (mm)	Material (mm)
50nb / 2"	60-68	M12	M8 x 25	25 x 2
67mm	66-73	M12	M8 x 25	25 x 2
65nb / 2 1/2"	74-81	M12	M8 x 25	25 x 2
85mm	82-88	M12	M8 x 25	25 x 2
80nb / 3"	88-97	M12	M8 x 25	25 x 2
100mm	93-100	M12	M8 x 25	25 x 2
105mm	101-109	M12	M8 x 25	30 x 2.5
100nb / 4"	110-118	M12	M8 x 25	30 x 2.5
120mm	116-126	M12	M10 x 40	30 x .3
135mm	130-141	M12	M10 x 40	30 x .3
125nb / 5"	136-145	M12	M10 x 40	30 x .3
145mm	144-154	M12	M10 x 40	30 x .3
150nb / 6"	160-169	M12	M10 x 40	30 x .3
175mm	170-180	M16	M10 x 40	30 x .3
200nb / 8"	219-230	M16	M10 x 40	30 x .3
250nb / 10"	273-283	M16	M10 x 40	30 x .3

# Heavy Duty Surefix *HD* Rubber Lined Clip

For Copper, Plastic and Stainless Steel Pipes

## Construction

Mild Steel BZP Finish

## For Use With

Copper & Plastic Tubes

## Special Features

Rubber Lining tested to DIN4109 for Acoustic Use



Pipe Size	Grip Range (mm)	Boss Type	Screw (mm)	Material (mm)
67cu / 2"	60-69	M12	M8 x 25	25 x 2
76cu / 2 1/2"	75-81	M12	M8 x 25	25 x 2
80nb / 3"	83-91	M12	M8 x 25	25 x 2
108cu	102-112	M12	M8 x 25	30 x 2.5
125mm	122-138	M12	M10 x 40	30 x 3
155mm	153-164	M12	M10 x 40	30 x 3
200mm	196-209	M16	M10 x 40	30 x 3



**Construction**  
Mild Steel  
BZP Finish  
HT Sets & Nuts

**For Use With**  
Steel Tubes  
Cast Iron Tubes  
Insulated Pipe Supports

**Other sizes available on request**

Size ID (mm)	Size NB	Hole Centres (mm)	Bolt Size (mm)	Material Width & Thickness (mm)
65		115	M10 x 40	30 x 3
76	65NB / 2 1/2"	125	M10 x 40	30 x 3
83		130	M10 x 40	30 x 3
89	80NB / 3"	137	M10 x 40	30 x 3
95		143	M12 x 40	30 x 3
102		156	M10 x 40	30 x 3
108		163	M10 x 40	40 x 3
114	100 NB / 4"	175	M10 x 40	40 x 3
121		187	M10 x 40	40 x 3
127		190	M10 x 40	40 x 3
133		200	M10 x 40	40 x 3
140		205	M10 x 40	40 x 3
146		210	M10 x 40	40 x 3
152		218	M10 x 40	40 x 3
159		228	M12 x 40	40 x 3
168	150 NB / 6"	236	M12 x 40	40 x 3
173		240	M12 x 50	40 x 3
178		248	M12 x 50	40 x 3
186		258	M12 x 50	40 x 5
193		265	M12 x 50	40 x 5
199		276	M12 x 50	40 x 5
208		284	M12 x 50	40 x 5
216		290	M12 x 50	40 x 5
220	200 NB / 8"	300	M12 x 50	40 x 5
225		302	M12 x 50	40 x 5
232		310	M12 x 50	40 x 5
244		313	M16 x 50	40 x 5
252		318	M16 x 50	40 x 5
259		320	M16 x 50	40 x 5
268		336	M12 x 50	40 x 5
273	250 NB / 10"	360	M16 x 50	50 x 6
283		364	M16 x 50	50 x 6
290		374	M16 x 50	50 x 6
298		383	M16 x 50	50 x 6
308		405	M16 x 50	50 x 6
323	300 NB / 12"	420	M16 x 50	50 x 6



## Construction

Mild Steel  
 Nylon Coated Finish  
 HT Sets & Nuts

## For Use With

Copper Tubes  
 Stainless Steel Tubes



Size ID (mm)	Size NB (cu)	Hole Centres (mm)	Bolt Size (mm)	Material Width & Thickness (mm)
15	15	50	M6 x 25	25 x 3
22	22	59	M6 x 25	25 x 3
28	28	65	M6 x 25	25 x 3
35	35	72	M6 x 25	25 x 3
42	42	92	M10 x 30	30 x 3
54	54	104	M10 x 30	30 x 3
67	67	116	M10 x 30	30 x 3
76	76	126	M10 x 30	30 x 3
108	108	158	M10 x 30	30 x 3
133	133	193	M10 x 40	40 x 3
159	159	219	M10 x 40	40 x 3

## Split Band Assembly Components

DST 190 - Eye Bolt



**Construction**  
 Mild Steel BZP Finish

**Sizes Available**  
 M8, M10, M12, M16, M20  
 Length - 100mm, 150mm, 200mm

DST 200 - Link Eye



**Construction**  
 Cast Malleable Iron  
 BZP Finish

**Sizes Available**  
 M8, M10, M12

DST 203 - Bow Nut



**Construction**  
 Mild Steel  
 BZP Finish

**Sizes Available**  
 M10, M12, M16, M20

# DST 105 - Bossed Split Band

For Steel Pipes & Insulated Pipe Supports

Created on: 15 Oct 2018

Version: 1.01

Last Updated: 14 Apr 2020

## Construction

Mild Steel

BZP Finish

HT Sets & Nuts

## For Use With

Steel Tubes

Cast Iron Tubes

Insulated Pipe Supports



Size ID (mm)	Size NB	Hole Centres (mm)	Boss	Bolt Size (mm)	Material Width & Thickness (mm)
65		115	M10	M10 x 40	30 x 3
76	65NB / 2 1/2"	125	M10	M10 x 40	30 x 3
83		130	M10	M10 x 40	30 x 3
89	80NB / 3"	137	M10	M10 x 40	30 x 3
95		143	M10	M10 x 40	30 x 3
102		156	M10	M10 x 40	30 x 3
108		163	M10	M10 x 40	40 x 3
114	100 NB / 4"	175	M10	M10 x 40	40 x 3
121		187	M12	M10 x 40	40 x 3
127		190	M12	M10 x 40	40 x 3
133		200	M12	M10 x 40	40 x 3
140		205	M12	M10 x 40	40 x 3
146		210	M12	M10 x 40	40 x 3
152		218	M12	M10 x 40	40 x 3
159		228	M12	M12 x 40	40 x 3
168	150 NB / 6"	236	M12	M12 x 40	40 x 3
173		240	M12	M12 x 50	40 x 3
178		248	M12	M12 x 50	40 x 3
186		258	M12	M12 x 50	40 x 5
193		265	M12	M12 x 50	40 x 5
199		276	M12	M12 x 50	40 x 5
208		284	M12	M12 x 50	40 x 5
216		290	M12	M12 x 50	40 x 5
220	200 NB / 8"	300	M12	M12 x 50	40 x 5
225		302	M12	M12 x 50	40 x 5
232		310	M12	M12 x 50	40 x 5
244		313	M12	M16 x 50	40 x 5
252		318	M12	M16 x 50	40 x 5
259		320	M12	M16 x 50	40 x 5
268		336	M12	M12 x 50	40 x 5
273	250 NB / 10"	360	M12	M16 x 50	50 x 6
283		364	M16	M16 x 50	50 x 6
290		374	M16	M16 x 50	50 x 6
298		383	M16	M16 x 50	50 x 6
308		405	M16	M16 x 50	50 x 6
323	300 NB / 12"	420	M16	M16 x 50	50 x 6



## Construction

Mild Steel  
 BZP Finish

## For Use With

Steel Tubes  
 Cast Iron Tubes  
 Insulated Pipe Supports



Size ID (mm)	Size NB	Hole Centres (mm)	Max Bolt Size (mm)	Material Width & Thickness (mm)
65		119	M12	30 x 3
76	65NB / 2 1/2"	144	M12	30 x 3
83		145	M12	30 x 3
89	80NB / 3"	163	M12	30 x 3
95		159	M12	30 x 3
102		166	M12	30 x 3
108		180	M12	40 x 3
114	100 NB / 4"	204	M12	40 x 3
121		192	M12	40 x 3
127		197	M12	40 x 3
133		204	M12	40 x 3
140		220	M12	40 x 3
146		212	M12	40 x 3
152		221	M12	40 x 3
159		228	M12	40 x 3
168	150 NB / 6"	238	M12	40 x 3
173		237	M12	40 x 3
178		247	M12	40 x 3
186		258	M12	40 x 3
193		262	M12	40 x 5
199		263	M12	40 x 5
208		268	M12	40 x 5
216		286	M12	40 x 5
220	200 NB / 8"	313	M12	40 x 5
225		297	M12	40 x 5
232		305	M12	40 x 5
244		313	M12	40 x 5



**Construction**  
Mild Steel  
Nylon Coated Finish

**For Use With**  
Copper Tubes  
Stainless Steel Tubes

Size ID (mm)	Size NB (cu)	Hole Centes (mm)	Bolt Size (mm)	Material Width & Thickness (mm)
15	15	53	8	25 x 3
22	22	60	8	25 x 3
28	28	71	8	25 x 3
35	35	74	8	25 x 3
42	42	94	12	30 x 3
54	54	108	12	30 x 3
67	67	120	12	30 x 3
76	76	130	12	30 x 3
108	108	162	12	30 x 3
133	133	197	14	40 x 3
159	159	223	14	40 x 3

## DST 170 - Filbow Clamp for Steel Pipes



**Construction**  
Cold Rolled Mild Steel  
Pre-Galv Finish

**For Use With**  
Steel Tubes

Nominal Imperial	OD (mm)	Height	Width (mm)	Hole Ø	Material (mm)
1/2"	28	51.5	36.5	10.5	25 x 1.2
3/4"	30	53.5	37.5	10.5	25 x 1.2
1"	36	65.5	46.5	10.5	25 x 1.2
1 1/4"	46	79.9	55.7	10.5	25 x 1.2
1 1/2"	52	85.9	58.7	10.5	25 x 1.2
2"	66	99.9	65.7	10.5	25 x 1.2
2 1/2"	78	116	75.5	10.5	25 x 1.5
3"	92	132	84.5	10.5	25 x 1.5
4"	116	167.5	107.5	10.5	25 x 2
5"	142	200	126.5	13	32 x 2.5
6"	170	238	150.5	13	32 x 3

## Properties

CFC/HCFC-free with zero Ozone Depletion Potential (ODP)

High Closed Cell Content

Inert Bore Coated for use on all Pipes Including Copper

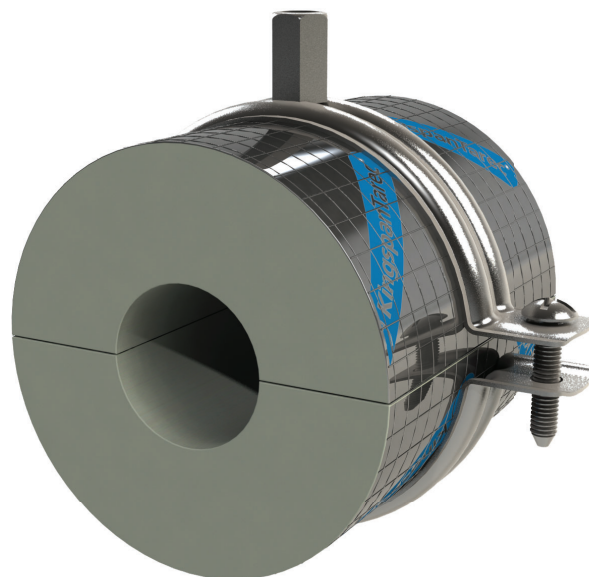

General Physical Properties (Metric)

Property	Test Method	Unit	Typical Value			
Nominal Density (Min)	(EN ISO 845) / (ASTM D 1622)	Kg/m <sup>3</sup>	37	60	80	120
Thermal Conductivity (Min)	(EN 12667) / (ASTM C 518)	W/m-K	0.021	0.029	0.03	0.032
Colour			Grey	Grey	Grey	Grey
Operating Temperature Limits	Upper Limit	°C	120	120	120	120
	Lower Limit	°C	-180	-180	-180	-180
Minimum Compressive Strength at +23 °C	(EN 826) / (ASTM D 1621) Parallel Perpendicular	kPa	150	320	590	1000
		kPa	100	170	440	800

Fire Test Specifications

Fire Test	Test Method	Specification			
Fire Propagation	BS 476-6: 1989	Index of Performance (I) not exceeding 12 and sub index (i1) not exceeding 6*			
Surface Spread of Flame	BS 476-7: 1997	Class 1*	Class 1*	Class 1*	Class 1*
Vertical Burning	DIN 4102-1: 1998	B2	B2	B2	B2

These test results combined enable a Class 0 classification to the Building Regulations in England & Wales, Northern Ireland and the Republic of Ireland, and a Low Risk classification to the Building Standards in Scotland. These tests were conducted on samples of 25mm/1" thickness faced with a reinforced aluminium foil vapour barrier jacket.



## Hard Wood Block Insulation



### Material

Hardwood - Kiln Dried

### Length

100mm (Tolerance of -1.5mm Maximum)

### Thickness

15, 20, 25, 30, 40, 50, 63, 75 (Other Thicknesses available upon request)

Tolerance on thickness not exceeding +/-1.5mm

### Bore Sizes

Steel - 15nb, 20nb, 25nb, 32nb, 40nb, 50nb, 65nb, 80nb, 100nb, 125nb, 150nb, 200nb, 250nb, 300nb

Copper - 15cu, 22cu, 28cu, 35cu, 42cu, 54cu, 67cu, 76cu, 108cu, 133cu, 159cu.

Plastic - Available upon request.

## Calcium Silicate Insulation

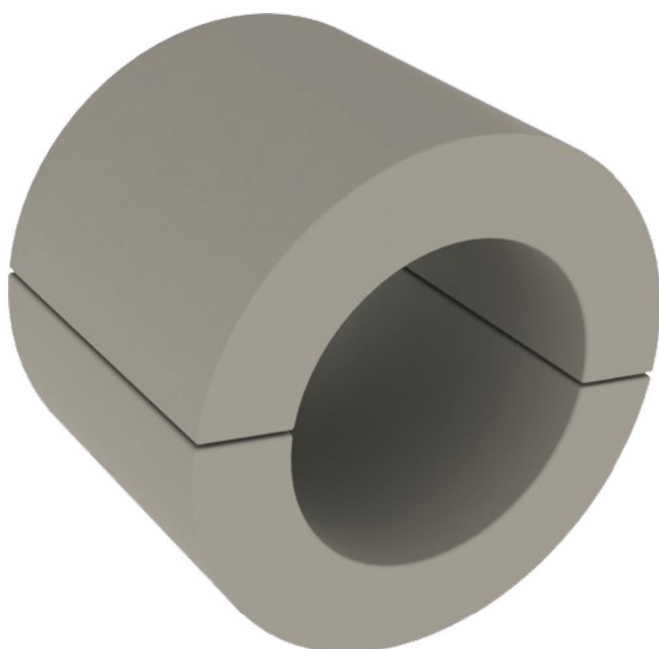

### Description

A tough and durable calcium silicate insulation offering exceptional thermal efficiency on hot process

applications. Non combustible, it is an inert material, containing no asbestos.

### Appearance

White/off white rigid insulation.

### Product Application

Calcium Silicate is an ideal insulation material for high temperature pipes. Used throughout the Petrochemical, Power Generation, Furnace and primary aluminium sectors, Calcium Silicate combines excellent thermal efficiency with high compressive strength, able to withstand foot traffic.

Typical Product Performance		
	Insulite 650	Insulite 1050
Maximum Service Temp:	650°C	1050°C
Age Density:	220kg/m <sup>3</sup>	265kg/m <sup>3</sup>
Compressive Strength:	0.8 Mpa	1.8Mpa
Combustibility:	Non-comb	Non-comb
Linear Shrinkage:	<2%	1.4%
Flexural Strength:	0.4 Mpa	0.8 Mpa
Thermal Conductivity @ 200°C	0.06W/mK	0.07W/mK

## Construction

Mild Steel  
 BZP Finish

## For Use With

Steel Tubes  
 Cast Iron Tubes  
 Insulated Pipe Supports



Size ID (mm)	Rod Dia (mm)	Size NB (mm)	Rod Dia (mm)
46	M10		
51	M10		
56	M10		
62	M10		
67	M10		
72	M10		
78	M10		
85	M10		
91	M10	15	M6
97	M10	20	M6
104	M10	25	M6
110	M10	32	M10
116	M10	40	M10
123	M10	50	M10
129	M10	65	M10
135	M12	80	M12
141	M12	100	M12
146	M12	125	M12
150	M12	150	M12
154	M12	200	M16
161	M12	250	M16
166	M12	300	M16
170	M12		
175	M12		
180	M12		
185	M12		
191	M12		
195	M12		
201	M12		
208	M12		
212	M12		
216	M12		
222	M12		
228	M12		
234	M12		
240	M12		
246	M12		
254	M16		
260	M16		
264	M16		
268	M16		
275	M16		
285	M16		
292	M16		
301	M16		
310	M16		

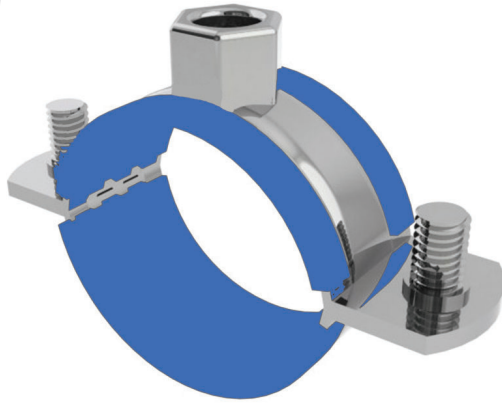

## Construction

Mild Steel  
BZP Finish

## For Use With

Copper & Plastic Tubes

## Special Features

Silicon Low Friction Lining

Size (mm)	Boss Size	Material Type	Temperature Limits °C	Part Number
16	M10	20 x 1	-10 - +90	GC16
20	M10	20 x 1	-10 - +90	GC20
25	M10	20 x 1	-10 - +90	GC25
32	M10	20 x 1	-10 - +90	GC32
40	M10	20 x 1.2	-10 - +90	GC40
50	M10	20 x 1.2	-10 - +90	GC50
56	M10	20 x 1.2	-10 - +90	GC56
63	M10	25 x 1.5	-10 - +90	GC63

## Expansion Products DSTMS1 & 2 Modular Slide Guide

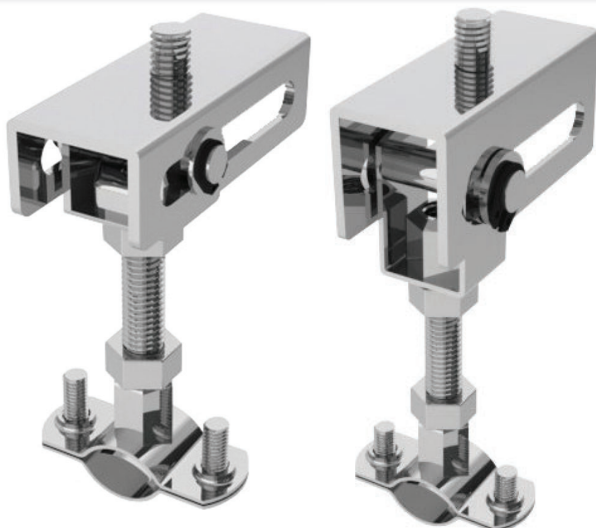

MS1 Slimline

MS2 Standard

## Construction

Mild Steel  
BZP Finish

## For Use With

Unlined & Rubber Lined  
Brackets to Create a Guided  
System

Type	Internal Thread	Max Travel	SWL
MS1	M10	50mm	0.25kN
MS2	M8/M10	50mm	0.25kN

## DST BH - Ball Hanger

## Construction

Mild Steel BZP Finish



Size	Movement	SWL
M8	+/-5°	0.15kN
M10	+/-5°	0.20kN
M12	+/-5°	0.25kN

## For Use With

Unlined & Lined Clip Range &  
Hanging brackets to reduce  
drop rod lateral loads



### Construction

Mild Steel BZP Finish  
 Low Friction Slide Insert

### For Use With

Unlined & Rubber Lined Clips  
 Surefix HD on Larger Sizes

### Special Features

Dual & Triple Bossed  
 Lockable for transport

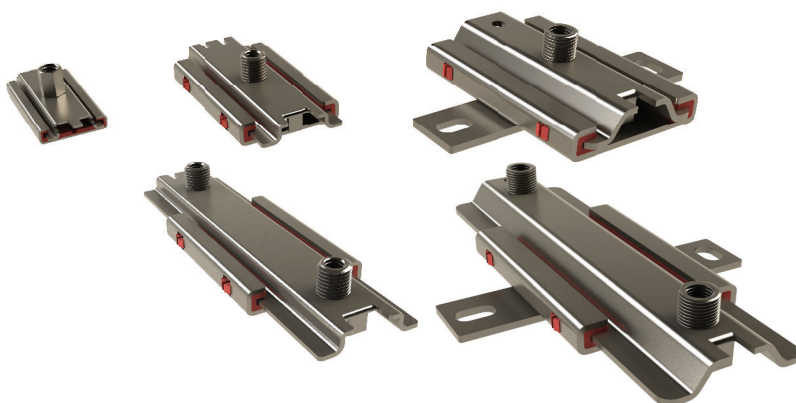

Type	Internal Thread	External Thread	Max Travel	SWL
LF1	M8/M10	N/A	65mm	0.5kN
LF2-1	M10	M16	90mm	2.0kN
LF2-2	M10	M16	120mm	2.0kN
LF3-1	M12/M16	1/2"	120mm	6.0kN
LF3-2	M12/M16	1/2"	135mm	6.0kN

				LF1		LF2-*		LF3-*	
									
									
Steel NB	Steel NB	Steel OD	CU OD	LF1-***UL	LF1-***RL	LF2-*-*UL	LF2-*-*RL	LF3-*-*UL	LF3-*-*RL
			15		LF1-015RL		LF2-*-*015RL		LF3-*-*015RL
			18	LF1-018UL	LF1-018RL	LF2-*-*018UL	LF2-*-*018RL	LF3-*-*018UL	LF3-*-*018RL
1/2"	15	21	22	LF1-021UL	LF1-022RL	LF2-*-*021UL	LF2-*-*022RL	LF3-*-*021UL	LF3-*-*022RL
3/4"	20	27	28	LF1-027UL	LF1-028RL	LF2-*-*027UL	LF2-*-*028RL	LF3-*-*027UL	LF3-*-*028RL
1"	25	34	35	LF1-034UL	LF1-035RL	LF2-*-*034UL	LF2-*-*035RL	LF3-*-*034UL	LF3-*-*035RL
1 1/4"	32	42	42	LF1-042UL	LF1-042RL	LF2-*-*042UL	LF2-*-*042RL	LF3-*-*042UL	LF3-*-*042RL
1 1/2"	40	48		LF1-048UL	LF1-048RL	LF2-*-*048UL	LF2-*-*048RL	LF3-*-*048UL	LF3-*-*048RL
			54		LF1-054RL		LF2-*-*054RL		LF3-*-*054RL
2"	50	60		LF1-060UL	LF1-060RL	LF2-*-*060UL	LF2-*-*060RL	LF3-*-*060UL	LF3-*-*060RL
			67				LF2-*-*067RL		LF3-*-*067RL
2 1/2"	65	76	76			LF2-*-*076UL	LF2-*-*076RL	LF3-*-*076UL	LF3-*-*076RL
3"	80	89				LF2-*-*089UL	LF2-*-*089RL	LF3-*-*089UL	LF3-*-*089RL
			108				LF2-*-*108RL		LF3-*-*108RL
4"	100	114				LF2-*-*114UL	LF2-*-*114RL	LF3-*-*114UL	LF3-*-*114RL
HEAVY DUTY									
								LF3-*-*HDUL	LF3-*-*HDRL
			133						LF3-*-*133HDRL
5"	125	140						LF3-*-*140HDUL	LF3-*-*140HDRL
			159						LF3-*-*159HDRL
6"	150	168						LF3-*-*168HDUL	LF3-*-*168HDRL
8"	200	220						LF3-*-*220HDUL	LF3-*-*220HDRL
10"	250	273						LF3-*-*273HDUL	LF3-*-*273HDRL
MAXIMUM TRAVEL				60mm		LF2-1 90mm	LF2-2 120mm	LF3-1 120mm	LF3-2 135mm

# DST AAB - Adjustable Anchor Bracket

## For Steel, Copper & Stainless Steel Pipes

Created on: 15 Oct 2018  
Version: 1.01  
Last Updated: 14 Apr 2020

The DST AAB Adjustable Anchor Bracket banks either 2 or 3 Split split bands on a set of steel cleat which can be adjusted for height and fall.

As a standard upto 54mm od bands will be powder coated, with larger sizes BZP for steel pipes or powder coated for copper & stainless steel.

Other band combinations are available upon request including brass, stainless steel & thicker profile steel bands.

### Construction

Mild Steel BZP Finish  
High Tensile BZP Set Screws

### For Use With

Copper, Steel & Stainless Steel pipes

### Special Features

Adjustable Height & Angle to facilitate fall in pipework.

Pipe Size	Band Material	Band QTY	Finish	SWL (kN)	Part Code	Torque Settings
15	25 x 3	2	Black Powder Coat	2.0	AB1015	40nm
22	25 x 3	2	Black Powder Coat	2.0	AB1022	40nm
28	25 x 3	2	Black Powder Coat	2.0	AB1028	40nm
15	25 x 3	2	Black Powder Coat	2.0	AB1022	40nm
20	25 x 3	2	Black Powder Coat	2.0	AB1028	40nm
25	25 x 3	2	Black Powder Coat	2.0	AB1035	40nm
15	25 x 3	3	Black Powder Coat	3.0	AB2015	40nm
22	25 x 3	3	Black Powder Coat	3.0	AB2022	40nm
28	25 x 3	3	Black Powder Coat	3.0	AB2028	40nm
35	25 x 3	3	Black Powder Coat	3.0	AB2035	40nm
42	30 x 3	3	Black Powder Coat	6.5	AB2042	60nm
54	30 x 3	3	Black Powder Coat	6.5	AB2054	60nm
67	30 x 3	3	Black Powder Coat	6.5	AB2067	60nm
76	30 x 3	3	Black Powder Coat	6.5	AB2076	60nm
108	40 x 3	3	Black Powder Coat	8.0	AB2108	60nm
133	40 x 3	3	Black Powder Coat	8.0	AB2133	60nm
159	40 x 3	3	Black Powder Coat	8.0	AB2159	60nm
15	25 x 3	3	Black Powder Coat	3.0	AB2022	40nm
20	25 x 3	3	Black Powder Coat	3.0	AB2028	40nm
25	25 x 3	3	Black Powder Coat	3.0	AB2035	40nm
32	25 x 3	3	Black Powder Coat	3.0	AB2042	60nm
40	30 x 3	3	Black Powder Coat	6.5	AB2040	60nm
50	30 x 3	3	BZP	6.5	AB2050	60nm
65	30 x 3	3	BZP	6.5	AB2065	60nm
80	30 x 3	3	BZP	6.5	AB2080	60nm
100	40 x 3	3	BZP	8.0	AB2100	60nm
125	40 x 3	3	BZP	8.0	AB2125	60nm
150	40 x 3	3	BZP	8.0	AB2150	60nm

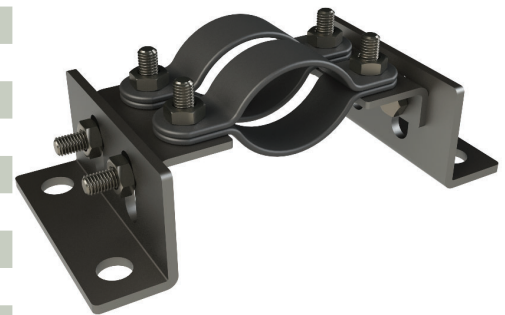

## Construction

Mild Steel BZP or Powder Finish  
 High Tensile BZP Set Screws

## For Use With

Copper, Steel & Stainless Steel  
 pipes

## Special Features

Fabricated on Site using DST100  
 or DST130 Split Bands

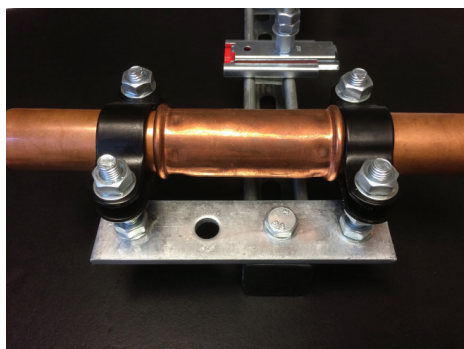

The Slip Anchor and Band Anchor are an effective way of installing anchors on site with relatively low costs.

The idea is to use multiple split bands to ensure a firm mechanical grip on the pipework. In the case of the Slip Anchor, a band is placed on either side of a slip coupling to add a failsafe mechanism. The coupling could be any type of slip coupling, but not a pipe connector unless its a welded flange.

Pipe Size	Band Material	No Of Bands	Finish	Anchor Type
15	25 x 3	2	Black Powder Coat	Slip
22	25 x 3	2	Black Powder Coat	Slip
28	25 x 3	2	Black Powder Coat	Slip
35	25 x 3	2	Black Powder Coat	Slip
42	30 x 3	2	Black Powder Coat	Slip
54	30 x 3	2	Black Powder Coat	Slip
67	30 x 3	2	Black Powder Coat	Slip
76	30 x 3	2	Black Powder Coat	Slip
108	40 x 3	2	Black Powder Coat	Slip

15	25 x 3	2	Black Powder Coat	Slip
20	25 x 3	2	Black Powder Coat	Slip
25	25 x 3	2	Black Powder Coat	Slip
32	25 x 3	2	Black Powder Coat	Slip
40	30 x 3	2	Black Powder Coat	Slip
50	30 x 3	2	BZP	Slip
65	30 x 3	2	BZP	Slip
80	30 x 3	2	BZP	Slip
100	40 x 3	2	BZP	Slip

Pipe Size	Band Material	No Of Bands	Finish	Anchor Type
15	25 x 3	2	Black Powder Coat	Band
22	25 x 3	2	Black Powder Coat	Band
28	25 x 3	2	Black Powder Coat	Band
35	25 x 3	2	Black Powder Coat	Band
42	30 x 3	2	Black Powder Coat	Band
54	30 x 3	3	Black Powder Coat	Band
67	30 x 3	3	Black Powder Coat	Band
76	30 x 3	3	Black Powder Coat	Band
108	40 x 3	3	Black Powder Coat	Band

15	25 x 3	2	Black Powder Coat	Band
20	25 x 3	2	Black Powder Coat	Band
25	25 x 3	2	Black Powder Coat	Band
32	25 x 3	2	Black Powder Coat	Band
40	30 x 3	2	Black Powder Coat	Band
50	30 x 3	3	BZP	Band
65	30 x 3	3	BZP	Band
80	30 x 3	3	BZP	Band
100	40 x 3	3	BZP	Band





**Construction**  
Mild Steel  
HT Sets & Nuts

**For Use With**  
Steel Tubes  
Cast Iron Tubes  
Insulated Pipe Supports

Nominal Imperial	Pipe Size Metric (NB)	Material A (mm)	Material B (mm)	Bolt Size
1/2"	15	30 x 3	30 x 5	M10 x 30
3/4"	20	30 x 3	30 x 5	M10 x 30
1"	25	30 x 3	30 x 5	M10 x 30
1 1/4"	32	30 x 3	30 x 5	M10 x 30
1 1/2"	40	30 x 3	30 x 5	M10 x 30
2"	50	30 x 3	30 x 5	M10 x 30
2 1/2"	65	30 x 3	30 x 5	M10 x 30
3"	80	40 x 3	40 x 5	M12 x 40
4"	100	40 x 3	40 x 5	M12 x 40
5"	125	50 x 3	50 x 6	M16 x 50
6"	150	50 x 3	50 x 6	M16 x 50
8"	200	50 x 6	50 x 8	M16 x 50

## DST 115 Hanging Roller



**Construction**  
Mild Steel

**For Use With**  
Steel Tubes  
Cast Iron Tubes  
Insulated Pipe Supports

Nominal Imperial	Pipe Size Metric (NB)	Hole Ø	Material (mm)
1/2"	15	12	30 x 3
3/4"	20	12	30 x 3
1"	25	12	30 x 3
1 1/4"	32	12	30 x 3
1 1/2"	40	12	30 x 3
2"	50	12	30 x 3
2 1/2"	65	12	30 x 3
3"	80	14	40 x 3
4"	100	14	40 x 3
5"	125	19	50 x 6
6"	150	19	50 x 6
8"	200	23	60 x 8



## Construction

Mild Steel  
 HT Sets & Nuts

## For Use With

Steel Tubes  
 Cast Iron Tubes  
 Insulated Pipe Supports



Nominal Imperial	Pipe Size Metric (NB)	Material (mm)	Fixing Holes
1/2"	15	30 x 5	12
3/4"	20	30 x 5	12
1"	25	30 x 5	12
1 1/4"	32	30 x 5	12
1 1/2"	40	30 x 5	12
2"	50	30 x 5	12
2 1/2"	65	30 x 5	12
3"	80	40 x 5	12
4"	100	40 x 5	12
5"	125	50 x 6	14
6"	150	50 x 6	14
8"	200	50 x 8	19

# DST 134 S/E 'U' Bolt

For Copper Pipes

## Construction

Mild Steel  
 Nylon Coated Finish

## For Use With

Copper Tubes  
 Stainless Steel Tubes

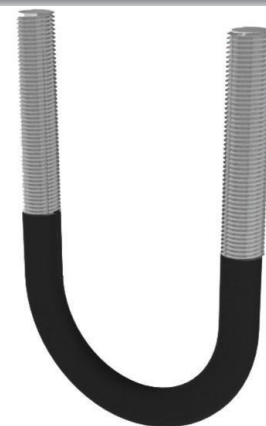

Size ID (mm)	Size NB (cu)	Rod Ø	Leg Centres	Thread Length Standard	Thread Length Extended
15	15	M6	22	30	75
22	22	M6	29	30	75
28	28	M6	35	30	75
35	35	M6	42	30	85
42	42	M8	52	40	85
54	54	M8	64	40	85
67	67	M8	76	40	85
76	76	M10	88	40	85
108	108	M10	120	40	85
133	133	M10	145	40	85
159	159	M12	173	40	85

## DST 240 G/M/B - Munsen Rings

Construction

Metric Threads



240G = Galvanised

240M = Malleable  
Iron

240B = Cast Brass

## DST 241 G/M/B - School Board Clips



241G = Galvanised

241M = Malleable  
Iron

241B = Cast Brass

## DST 242 G/M/B - Backplates



242G = Galvanised

242M = Malleable  
Iron

242B M10 Male & Female Threads

## High Tensile Nut

### Construction

Steel Grade 8.8 DIN934.  
Cold Formed.  
BZP Finish

### Sizes Available

M4, M5, M6, M8, M10,  
M12, M16, M20, M24

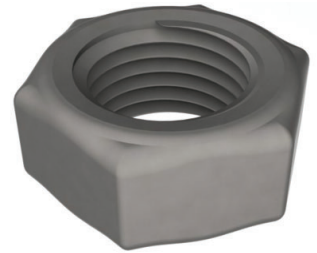

## Wedge Nut

### Construction

Mild Steel  
BZP Finish

### Sizes Available

M6, M8, M10 & M12

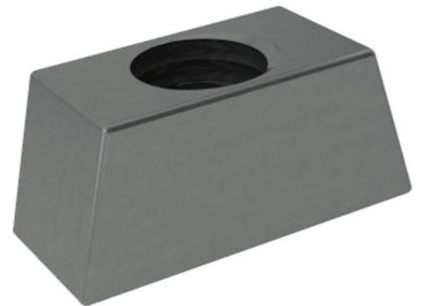

## Flange Clamp

### Construction

Mild Steel  
BZP Finish

### Sizes Available

M8, M10 & M12





## STRUT: Plain or Slotted

- 41 x 41 x 6m
- 41 x 41 x 3m
- 41 x 21 x 6m
- 41 x 21 x 3m
- 41 x 41 x 6m Back to Back
- 41 x 41 x 3m Back to Back
- 41 x 21 x 6m Back to Back
- 41 x 21 x 3m Back to Back

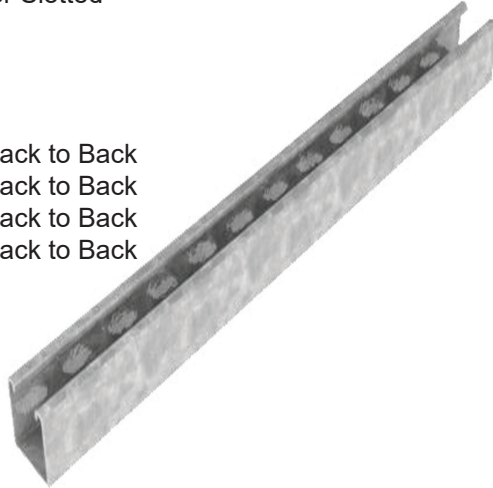

## CANTILEVER ARMS

- 150mm Long
- 300mm Long
- 450mm Long
- 600mm Long
- 750mm Long
- 900mm Long

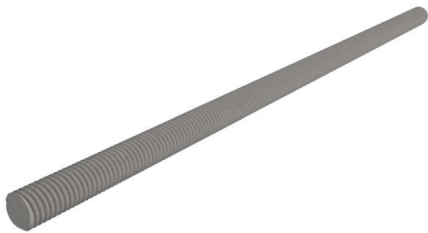
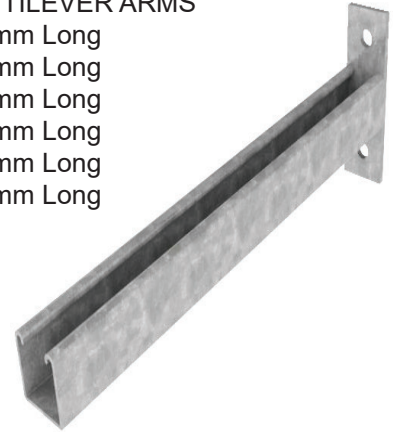

STUDDING 1m & 3m

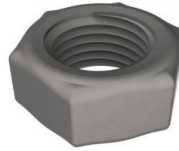

NUTS

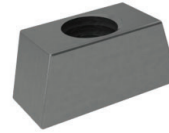

WEDGE NUTS



WASHERS



BOLTS & SETS



PURLIN CLIPS



CHANNEL NUTS

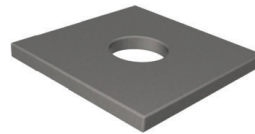

DST01



DST02

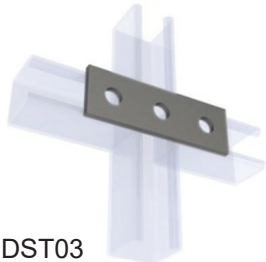

DST03



DST04



DST05



DST06



DST07



DST08



DST09  
41 x 21

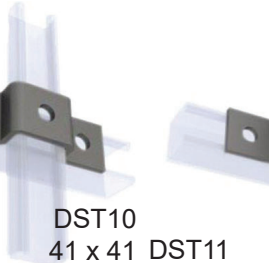

DST10  
41 x 41

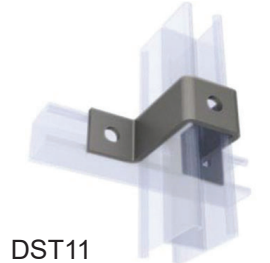

DST11



DST12



DST13

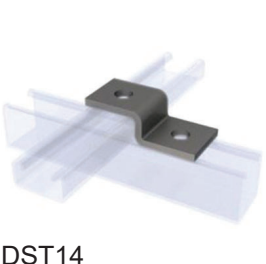

DST14



DST15



DST16



DST17



DST18

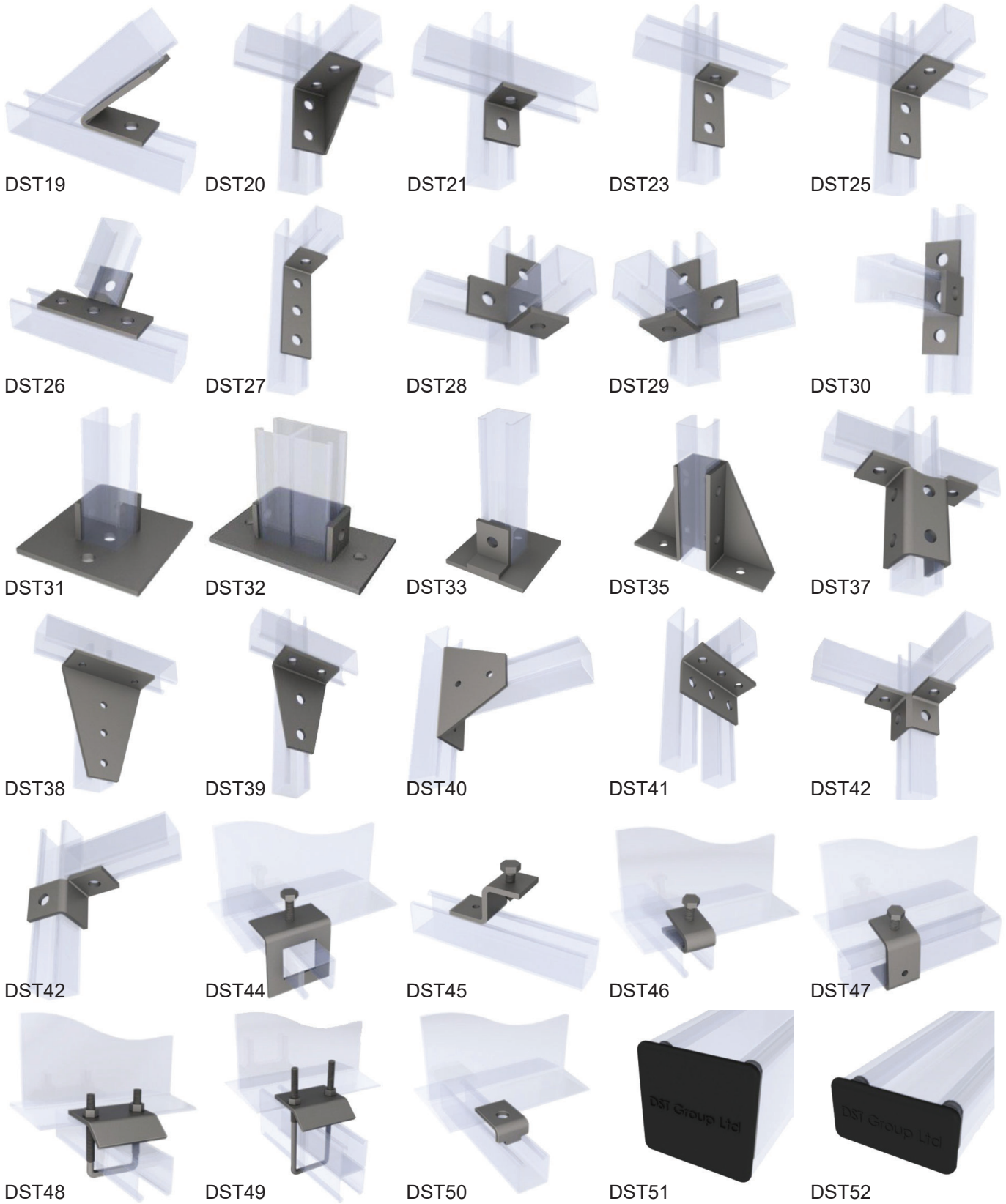

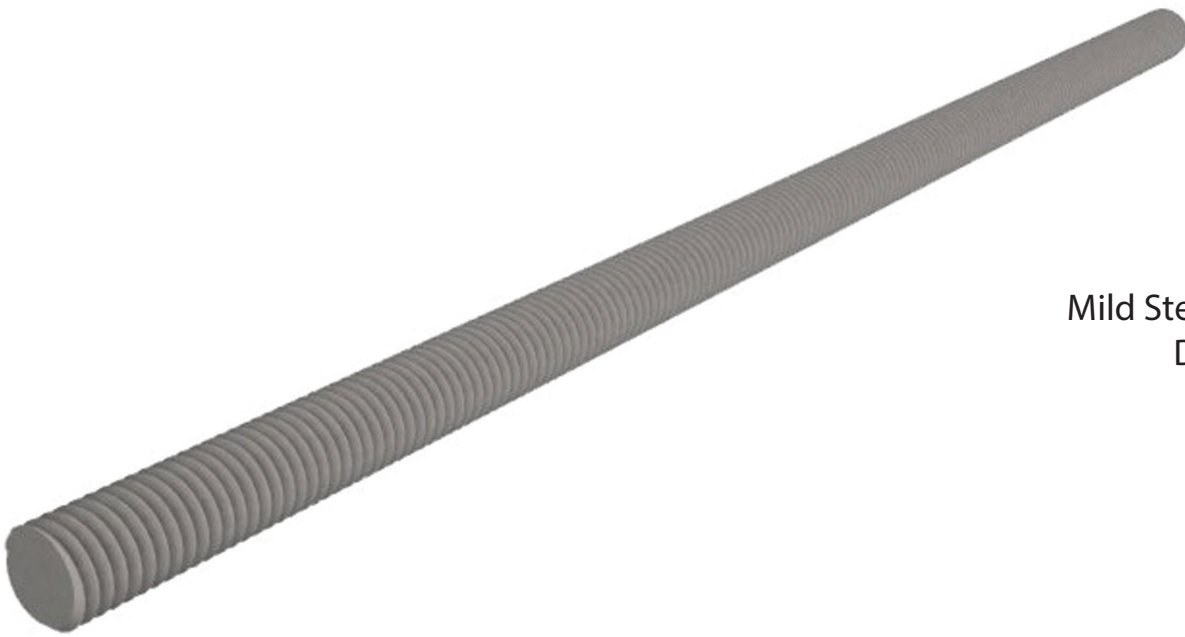

## Construction

Mild Steel 4.8 Grade to  
DIN EN20891.-1

BZP Finish

Standard Lengths	Cut Lengths (mm)			
Size	Size	Size	Size	Size
M6 x 1m	M10 x 25	M10 x 160	M10 x 295	M10 x 430
M6 x 3m	M10 x 30	M10 x 165	M10 x 300	M10 x 435
M8 x 3m	M10 x 35	M10 x 170	M10 x 305	M10 x 440
M10 x 1m	M10 x 40	M10 x 175	M10 x 310	M10 x 445
M10 x 3m	M10 x 45	M10 x 180	M10 x 315	M10 x 450
M12 x 1m	M10 x 50	M10 x 185	M10 x 320	M10 x 455
M16 x 1m	M10 x 55	M10 x 190	M10 x 325	M10 x 460
M16 x 3m	M10 x 60	M10 x 195	M10 x 330	M10 x 465
M20 x 1m	M10 x 65	M10 x 200	M10 x 335	M10 x 470
M20 x 3m	M10 x 70	M10 x 205	M10 x 340	M10 x 475
M24 x 1m	M10 x 75	M10 x 210	M10 x 345	M10 x 480
M24 x 3m	M10 x 80	M10 x 215	M10 x 350	M10 x 485
	M10 x 85	M10 x 220	M10 x 355	M10 x 490
	M10 x 90	M10 x 225	M10 x 360	M10 x 495
	M10 x 95	M10 x 230	M10 x 365	M10 x 500
	M10 x 100	M10 x 235	M10 x 370	M10 x 505
	M10 x 105	M10 x 240	M10 x 375	M10 x 510
	M10 x 110	M10 x 245	M10 x 380	M10 x 515
	M10 x 115	M10 x 250	M10 x 385	M10 x 520
	M10 x 120	M10 x 255	M10 x 390	M10 x 525
	M10 x 125	M10 x 260	M10 x 395	M10 x 530
	M10 x 130	M10 x 265	M10 x 400	M10 x 535
	M10 x 135	M10 x 270	M10 x 405	M10 x 540
	M10 x 140	M10 x 275	M10 x 410	M10 x 545
	M10 x 145	M10 x 280	M10 x 415	M10 x 550
	M10 x 150	M10 x 285	M10 x 420	M10 x 555
	M10 x 155	M10 x 290	M10 x 425	M10 x 560



# Expansion & Anti-Vibration

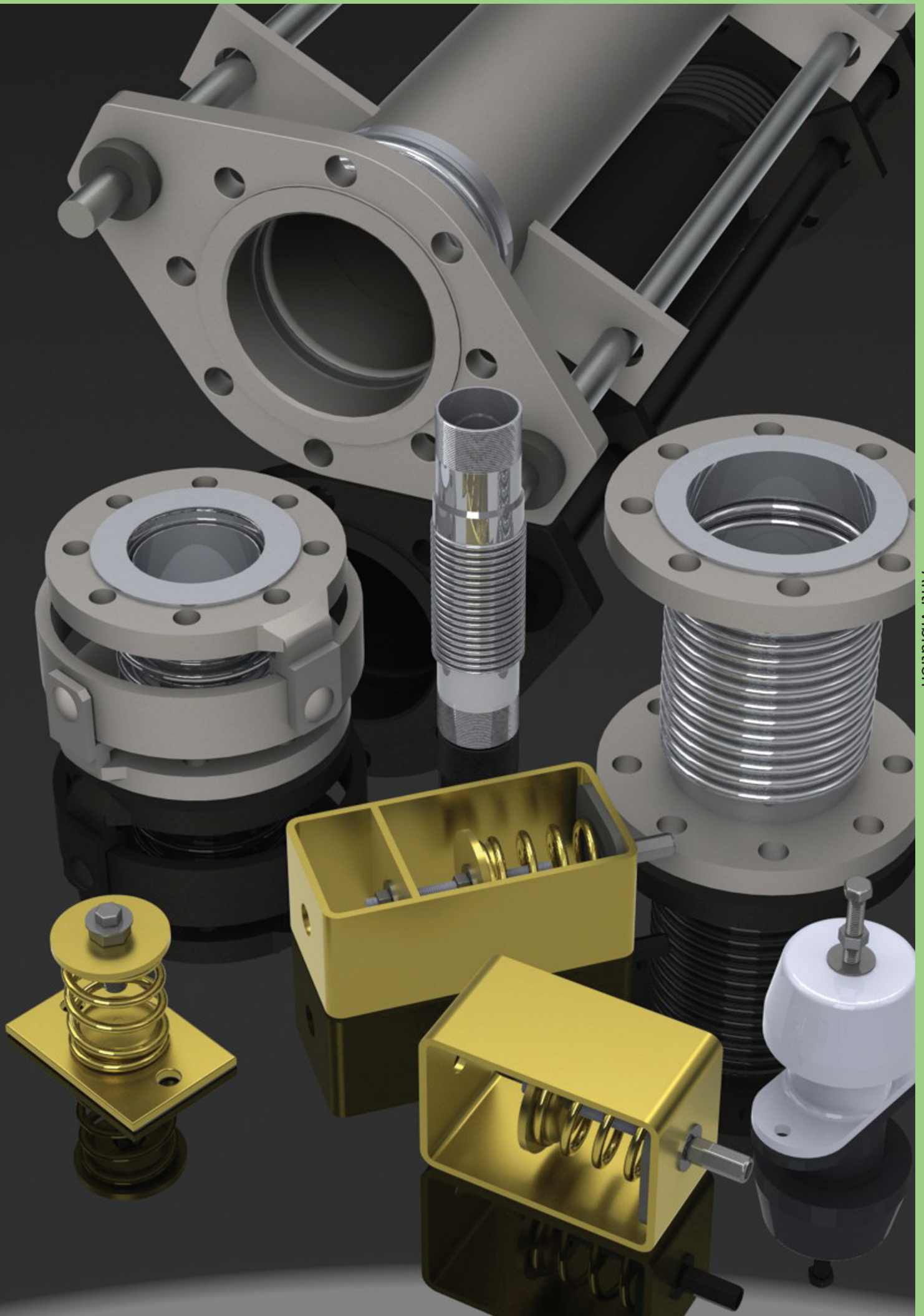

- 31 AX2 Axial Bellows
- 32 AX1 Axial Bellows
- 33 AX3 Screwed Axial Bellows
- 34 AX3(SPE) Axial Bellows c/w Stainless Pipe Ends
- 35 FA1 & FA2 Fully Articulated Bellows
- 36 AN1 & AN2 Angular Bellows
- 37 GI1 & GI2 Gimbal Bellows
- 38 Untied EPDM Pump Flexibles
- 39 Tied EPDM Pump Flexibles
- 40 Screwed EPDM Pump Flexibles
- 43 FA3 Stainless Steel Pump Flexibles
- 44 EPDM Hoses
- 45 Stainless Steel Hoses
- 47 Inertia Bases
- 48 Enclosed Spring Mounts
- 49 Restrained Spring Mounts
- 50 Open Spring Mounts
- 51 Neprene Mounts and Hangers
- 52 -53 Spring Hangers
- 54 Air & Dirt Separators
- 56 Dosing Pots

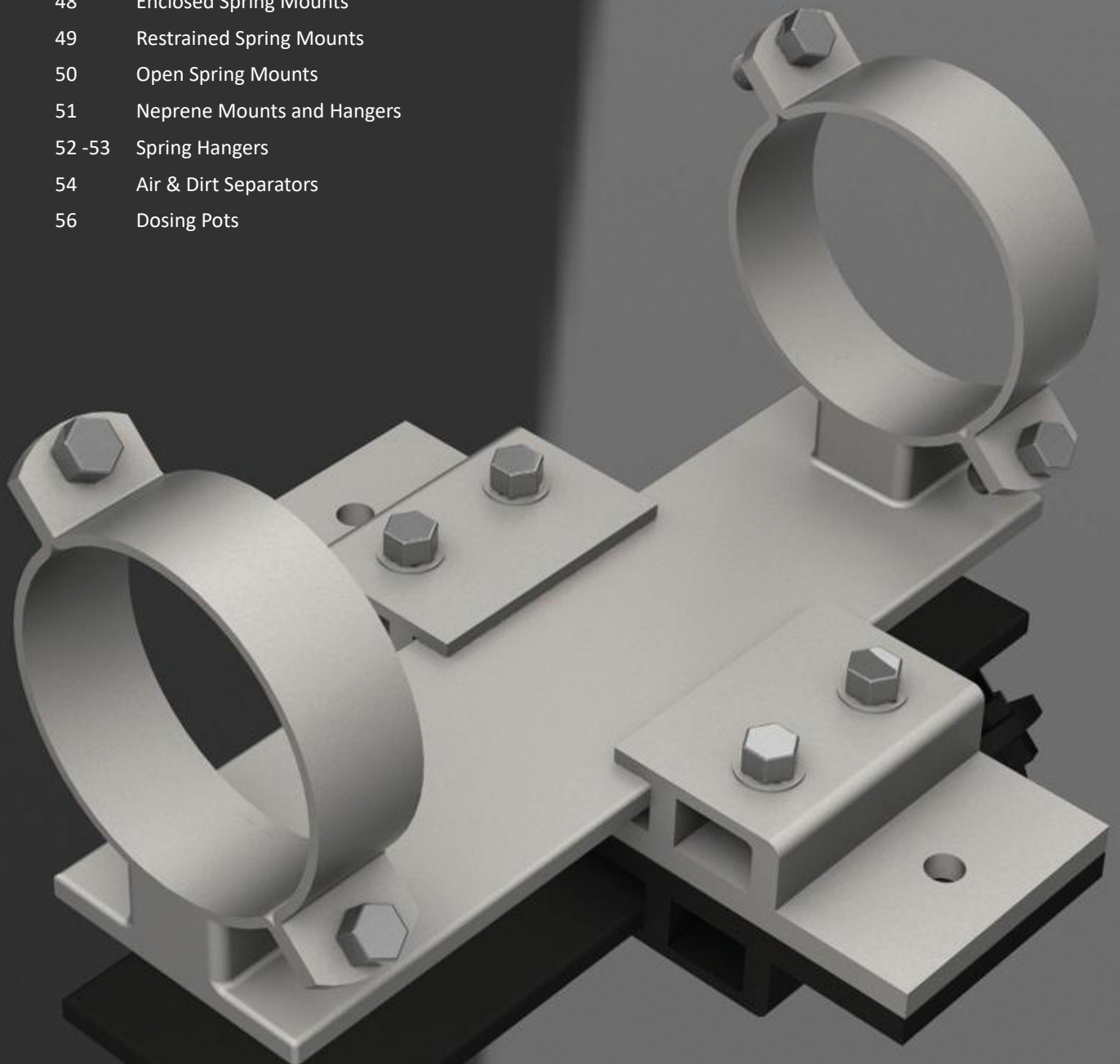



## Key Points

- Require Full Guiding
- Available for any Temperature or Pressure
- Supplied with CE Certs where Applicable
- Internal Flow Liner as Standard
- Bellows are Pre-Cold Drawn



### DST Type AX2 Axial Bellows

Designed to accept linear expansion on copper and stainless steel pipe systems.

Standard product details are shown below, although these may vary dependant upon application and PED requirements.

### Material Specification

Flanges: (Stainless steel to all wetted areas)	Carbon Steel PN16 With Stainless steel facings
Convolutions:	316 Stainless Steel
Internal Sleeve:	316 Stainless Steel

### Working Conditions

Pressure:	16 Bar
Temperature:	120 Degrees C
Test:	1.5x Working

### PED Requirements

All Bellows supplied by DST Group Ltd are manufactured and certified in accordance with EU PED Legislation and as such carry the relevant CE certification where required.

Size (mm)	Axial Compression (mm)	Installed Length	Effective Area cm <sup>2</sup>	Force to Compress N/mm	Part Number
32nb / 35cu	30	130	12.8	37	AX2/032/PN16
40nb / 42cu	30	130	19.0	37	AX2/040/PN16
50nb / 54cu	50	225	35.6	55	AX2/050/PN16
65nb / 67cu	50	225	46.5	87	AX2/065/PN16
80nb / 76cu	50	230	61.7	90	AX2/080/PN16
100nb / 108cu	50	230	103.2	116	AX2/100/PN16
125nb / 133cu	60	240	177.5	118	AX2/125/PN16
150nb / 159cu	60	240	253.6	166	AX2/150/PN16
200nb	70	275	453.5	176	AX2/200/PN16
250nb	70	280	684.6	276	AX2/250/PN16

- The anchor loads generated by this type of Axial Expansion Compensator are high. A bracket guide with a low frictional resistance should be used.

Please note these units are not suitable for use on a drop rod system and need to be suitably guided (e.g. DST LF Slide Guide or DST 253 Slide Guide). Please consult the Expansion Compensator Application Guide for positioning of anchor points and subsequent support centres. (See page 116)

### Primary Pipe Guide Spacings



### Key Points

Require Full Guiding

Available for any Temperature or Pressure

Supplied with CE Certs where Applicable

Internal Flow Liner as Standard

Bellows are Pre-Cold Drawn

### DST Type AX1 Axial Bellows

Designed to accept linear expansion on carbon steel and stainless steel pipe systems.

Standard product details are shown below, although these may vary dependant upon application and PED requirements.

### Material Specification

Carbon Steel PN16 With Stainless steel facings  
(Stainless steel to all wetted areas)

321 Stainless Steel (Available in 316 stainless steel for potable water)

321 Stainless Steel (Available in 316 or 304 stainless steel for potable water)

### Working Conditions

Pressure: 16 Bar

Temperature: To suit customer requirements

Test: 1.5x Working

### PED Requirements

All Bellows supplied by DST are manufactured and certified in accordance with EU PED Legislation and as such carry the relevant CE certification where required.

Size (mm)	Axial Compression (mm)	Installed Length	Effective Area cm <sup>2</sup>	Force to Compress N/mm	Part Number
32nb	30	210	15	61	AX1/032/PN16
40nb	30	215	22	78	AX1/040/PN16
50nb	50	233	40	135	AX1/050/PN16
65nb	50	233	62	107	AX1/065/PN16
80nb	50	233	81	295	AX1/080/PN16
100nb	50	233	127	379	AX1/100/PN16
125nb	60	336	196	295	AX1/125/PN16
150nb	60	336	273	355	AX1/150/PN16
200nb	70	372	470	284	AX1/200/PN16
250nb	70	372	700	354	AX1/250/PN16
300nb	70	372	958	420	AX1/300/PN16

The anchor loads generated by using this type of Axial Expansion Compensator are high. A guide bracket with a low frictional resistance should be used.

Please note these units are not suitable for use on a drop rod system and need to be suitably guided (e.g. DST 253 Slide Guide or DST 114 Roller Chair and Guide). Please consult the Expansion Compensator Application Guide for positioning of anchor points and subsequent support centres. (See Page 114)

### Primary Pipe Guide Spacings.



Primary Guide  
2-4 Pipe od's

Secondary Guide  
12 - 14 Pipe od's

Anchor  
Point



## Key Points

- Require Full Guiding
- Available in any Temperature or Pressure
- Supplied with CE certs where Applicable
- Internal Flow liner as Standard
- Bellows are Pre-Cold Drawn
- Material Specification



### DST Type AX3 Axial Bellows

Designed to accept linear expansion on Steel & Copper pipe systems.

### Working Conditions

Pressure: Standard 10 Bar (Upto 16 Bar - Dependant on PED Conditions)  
 Temperature: 120 Degrees C  
 Test: 1.5x Working

### PED Requirements

All Bellows supplied by DST Group Ltd are manufactured and certified in accordance with EU PED Legislation and as such carry the relevant CE certification where required.

Size (mm)	Axial Compression (mm)	Installed Length	Effective Area cm <sup>2</sup>	Force to Compress N/mm	Part Number
15	25	200	3	3.9	AX3/015/MSC(25)
20	25	200	6	7.8	AX3/020/MSC(25)
25	25	200	9	12.7	AX3/025/MSC(25)
32	25	210	13	17.2	AX3/032/MSC(25)
40	25	220	20	19.6	AX3/040/MSC(25)
50	25	250	30	19.6	AX3/050/MSC(25)
65	25	273	50	25.0	AX3/065/MSC(25)
15	50	300	3	3.9	AX3/015/MSC(50)
20	50	300	6	7.8	AX3/020/MSC(50)
25	50	300	9	12.7	AX3/025/MSC(50)
32	50	310	13	17.2	AX3/032/MSC(50)
40	50	320	20	19.6	AX3/040/MSC(50)
50	50	350	30	19.6	AX3/050/MSC(50)

The anchor loads generated by using this type of Axial Expansion Compensator are high. It is worth keeping in mind the type of pipework bracketry that will be used. A guide bracket with a low frictional resistance should be used such as DST LF Slide guides or DST Guide Clips.

Please note these units are not suitable for use on a drop rod system and need to be suitably guided. Please consult the Expansion Compensator Application Guide for positioning of anchor points and subsequent support centres. (See Page 116)

### Primary Pipe Guide Spacings

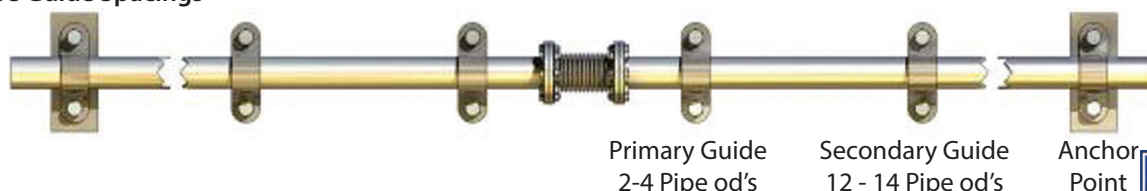

### Key Points

Require Full Guiding

Available for any Temperature or Pressure

Supplied with CE Certs where Applicable

Internal Flow Liner as Standard

Bellows are Pre-Cold Drawn



#### DST Type AX3 (SPE) Axial Bellows

Designed to accept linear expansion on Steel & Copper pipe systems.

#### Working Conditions

Pressure: Standard 10 Bar (Upto 16 Bar - Dependant on PED Conditions)  
Temperature: 120 Degrees C  
Test: 1.5x Working

#### PED Requirements

All Bellows supplied by DST Group Ltd are manufactured and certified in accordance with EU PED Legislation and as such carry the relevant CE certification where required.

Size (mm)	Axial Compression (mm)	Installed Length	Effective Area cm <sup>2</sup>	Force to Compress N/mm	Part Number
15	25	200	3.0	3.9	AX3/015/SPE(25)
18	25	200	3	7.8	AX3/012/SPE(25)
22	25	200	6	12.7	AX3/020/SPE(25)
28	25	200	9	12.7	AX3/025/SPE(25)
35	25	210	13	17.2	AX3/032/SPE(25)
42	25	220	20	19.6	AX3/040/SPE(25)
54	25	250	30	17.6	AX3/050/SPE(25)

The anchor loads generated by using this type of Axial Expansion Compensator are high. It is worth keeping in mind the type of pipework bracketry that will be used. A guide bracket with a low frictional resistance should be used such as DST LF Slide guides or DST Guide Clips.

Please note these units are not suitable for use on a drop rod system and need to be suitably guided. Please consult the Expansion Compensator Application Guide for positioning of anchor points and subsequent support centres. (See Page 116)

#### Primary Pipe Guide Spacings

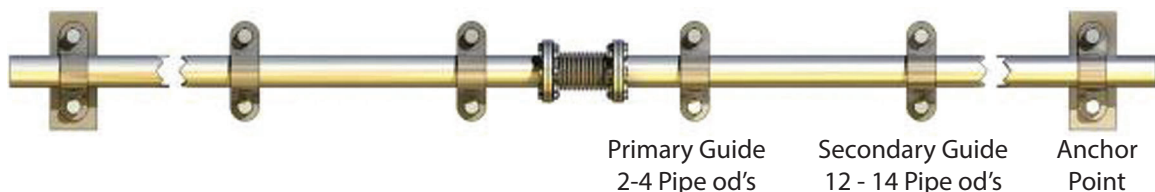

### Key Points

- FA1 for steel pipes
- FA2 for copper & stainless steel
- Supplied with CE certs where applicable
- Internal flow liner as standard

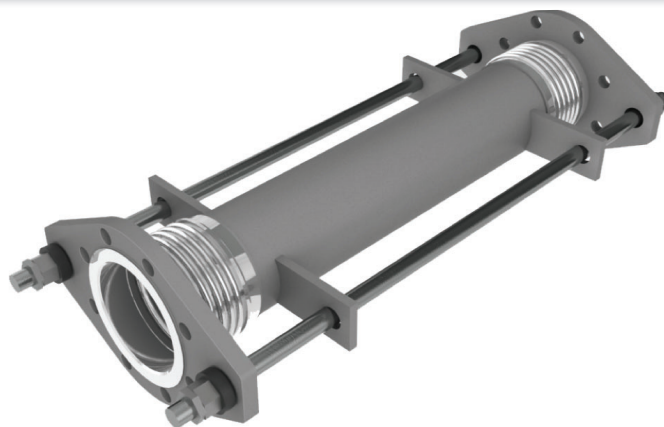

Size	Installed Length +/- 25 (mm)	Force to Deflect +/- 25mm (N/mm)	Installed Length +/- 50 (mm)	Force to Deflect +/- 50 (mm)	Part Number
25	465	10.7	750	2.8	FA1/025/PN16
32	465	10.7	750	2.8	FA1/032/PN16
40	465	10.7	750	2.8	FA1/040/PN16
50	465	12.1	750	4	FA1/050/PN16
65	465	15.9	750	5	FA1/065/PN16
80	465	56.7	750	16	FA1/080/PN16
100	465	94.0	750	27	FA1/100/PN16
125	760	21.6	1000	11	FA1/125/PN16
150	760	38.2	1000	19	FA1/150/PN16
200	1010	29.8	1250	17	FA1/200/PN16
250	1010	55.2	1250	32	FA1/250/PN16

Size	Installed Length +/- 75 (mm)	Force to Deflect +/- 75mm (N/mm)	Installed Length +/- 100 (mm)	Force to Deflect +/- 100 (mm)	Part Number
25	1035	1.3	1320	1.3	FA1/025/PN16
32	1035	1.3	1320	1.3	FA1/032/PN16
40	1035	1.3	1320	1.3	FA1/040/PN16
50	1035	1.7	1320	1.3	FA1/050/PN16
65	1035	2.2	1320	1.3	FA1/065/PN16
80	1035	7.7	1320	2.7	FA1/080/PN16
100	1035	12.3	1320	5.4	FA1/100/PN16
125	1240	4.3	1480	5.4	FA1/125/PN16
150	1240	11.1	1480	4.5	FA1/150/PN16
200	1490	11.5	1730	4.5	FA1/200/PN16
250	1490	22.8	1730	4.5	FA1/250/PN16

### Material Specification

Connections:	Carbon Steel Drilled PN1 6 (Van-stone Facings on FA2)
Convolutions:	321 Stainless Steel (316 Stainless steel on FA2)
Internal Sleeve:	321 Stainless Steel (316 Stainless steel on FA2)
Tie Rods:	Carbon Steel
Hemispherical Washers:	Carbon Steel
Connecting Spool:	Carbon Steel (316 Stainless steel on FA2)

The DST Type FA1 & FA2 Lateral Expansion compensator is suitable for use on systems up to 250°C at 16 bar pressure PED certification supplied dependant upon application.

All units are supplied at installation lengths and are pre stressed. Please note DST Group Ltd can design and supply lateral expansion compensators to accommodate higher system temperatures / pressures and other rates of lateral movement or special dimensions. Please advise at time of enquiry / order the system temperature and pressure to allow correct selection of compensator.

### Standard Installation

These units are often used when new mains are being connected to existing mains. They allow a lateral movement to occur. These units are also useful for connections from boilers and plant, which will compensate any stresses put onto the "Headers". Advice should always be sought when using these units to ensure the units will allow the amount of movement which will occur. Please consult the Expansion Compensator Application Guide for positioning of the anchor points and subsequent support centres. (See page 116)

### Key Points

AN1 for Steel Pipes

AN2 for Copper & Stainless Steel

Supplied with CE Certs where Applicable

Internal Flow Liner as Standard



Size (mm)	Angular Deflection	Installed Length	Effective Area cm <sup>2</sup>	Force to Deflect Nm/deg	Part Number
25	+/- 5°	195	40	1.27	AN1/025/PN16
32	+/- 5°	195	40	3.04	AN1/032/PN16
40	+/- 5°	200	40	3.04	AN1/040/PN16
50	+/- 5°	133	40	3.34	AN1/050/PN16
65	+/- 5°	133	62	1.47	AN1/065/PN16
80	+/- 5°	133	81	1.47	AN1/080/PN16
100	+/- 5°	133	127	1.27	AN1/100/PN16
125	+/- 6.5°	199	195	3.04	AN1/125/PN16
150	+/- 6.5°	199	273	3.04	AN1/150/PN16
200	+/- 7.5°	212	469	3.34	AN1/200/PN16
250	+/- 7.5°	212	700	3.04	AN1/250/PN16

### Material Specification

Connections:	Carbon Steel Drilled PN16 (Van-stone facings on AN2) Other Flanges Available If Required
Convolutions:	321 Stainless Steel (316 Stainless steel on AN2)
Internal Sleeve:	321 Stainless Steel (316 Stainless steel on AN2)
Hinge Pins:	Carbon Steel

The DST Type AN1 & AN2 Angular Expansion compensators are suitable for use on systems up to 200°C at 16 bar pressure. All units are supplied at installation lengths and are pre stressed. Please note DST Group Ltd can design and supply angular expansion compensators to accommodate higher system temperatures / pressures or special dimensions. Please advise at time of enquiry / order the system temperature and pressure to allow correct selection of compensator.

### PED Requirements

CE Certificates issued if required. All units are categorised to PED standards, and we require accurate temperatures and pressures at time of order to enable correct selection and certification.

### Standard Installation

These units are commonly used in pairs, although three pin systems can be designed if required. Please contact our sales office for application and design advice. These units can be used on a drop rod system. Please consult the Expansion Compensator Application Guide for positioning of anchor points. (See page 116)



## Key Points

- GI1 for Steel Pipes
- GI2 for Copper & Stainless Steel
- Supplied with CE Certs where Applicable
- Internal Flow Liner as Standard



Size (mm)	Angular Deflection	Installed Length	Force to Deflect Nm/deg	Part Number
25	+/- 5°	195	8.3	GI1/025/PN16
32	+/- 5°	195	8.3	GI1/032/PN16
40	+/- 5°	195	8.3	GI1/040/PN16
50	+/- 5°	180	8.3	GI1/050/PN16
65	+/- 5°	180	10.1	GI1/065/PN16
80	+/- 5°	180	31.4	GI1/080/PN16
100	+/- 5°	180	60.8	GI1/100/PN16
125	+/- 6.5°	225	36.2	GI1/125/PN16
150	+/- 6.5°	225	55.3	GI1/150/PN16
200	+/- 7.5°	250	107.1	GI1/200/PN16
250	+/- 7.5°	250	192	GI1/250/PN16

## Material Specification

Connections:	Carbon Steel Drilled PN16 (Van-stone facings on GI2) Other Flanges Available If Required
Convolutions:	321 Stainless Steel (316 Stainless steel on GI2)
Internal Sleeve:	321 Stainless Steel (316 Stainless steel on GI2)
Hinge Pins:	Carbon Steel

The DST Type GI1 & GI2 Gimbal Expansion compensators are suitable for use on systems up to 200°C at 16 bar pressure. All units are supplied at installation lengths and are pre stressed.

Please note DST Group Ltd can design and supply gimbal expansion compensators to accommodate higher system temperatures / pressures or special dimensions. Please advise at time of enquiry / order the system temperature and pressure to allow correct selection of compensator.

## PED Requirements

CE Certificates issued if required. All units are categorised to PED standards, and we require accurate temperatures and pressures at time of order to enable correct selection and certification.

## Standard Installation

These units are commonly used in pairs, although three pin systems can be designed if required. Please contact our sales office for application and design advice. These units can be used on a drop rod system. (See page 116)

### Key Points

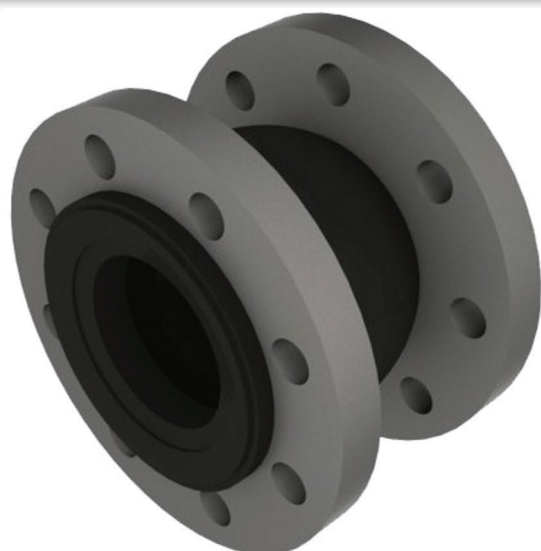

Flanges: Carbon Steel - Drilled PN16 or PN6 (Other Flanges Available)

Nylon Re-inforced EPDM Rubber Body

Steel Reinforced Collars

Round flanges - No Tie Bars

Size (mm)	Installed Length	Material Type	Temperature Limits °C	Part Number
32	130	Nylon Reinforced EPDM	-10 - 90	DST/032/PN16/6
40	130	Nylon Reinforced EPDM	-10 - 90	DST/040/PN16/6
50	130	Nylon Reinforced EPDM	-10 - 90	DST/050/PN16/6
65	130	Nylon Reinforced EPDM	-10 - 90	DST/065/PN16/6
80	130	Nylon Reinforced EPDM	-10 - 90	DST/080/PN16/6
100	130	Nylon Reinforced EPDM	-10 - 90	DST/100/PN16/6
125	130	Nylon Reinforced EPDM	-10 - 90	DST/125/PN16/6
150	130	Nylon Reinforced EPDM	-10 - 90	DST/150/PN16/6

- DST D-Flex Pump Flexibles are installed to absorb vibration and noise levels caused by "Plant" upon which they are fitted. These are suitable for use on systems carrying Chilled & Heating Water. Please see above for temperature & Pressure limits.
- DST D Flex units are not suitable for use with Potable Water, Water with Oil additives, Compressed Air and Food Applications.
- DST D Flex Untied units should not be installed on pumps located on Inertia bases
- DST D-Flex units are manufactured from spherical moulded EPDM, which is a soft compound to offer a high isolation efficiency and high noise absorbing properties.
- The units are a full bore thus removing pressure drop problems. The EPDM rubber is nylon re-inforced, and has a steel wire re-inforced collar.
- Flanges BZP coated carbon steel PN16.
- D-Flex units have a 10 year design life and are warranted for a period of 12 months from supply.
- DST D Flex units are stamped with Origin of Manufacture, Date Of Manufacture, Batch Number and Size.
- Please note no torsion forces should be applied to these units.
- DST Group Ltd also Supply DIN 4809 Approved Pump Flexibles. Please Contact our Sales Office for further information.

## Key Points

- Flanges: Carbon Steel - Drilled PN16  
(Other Flanges Available)
- Nylon Re-inforced EPDM Rubber Body
- Steel Reinforced Collars
- Tie Bars: Anti-Tamper Carbon Steel

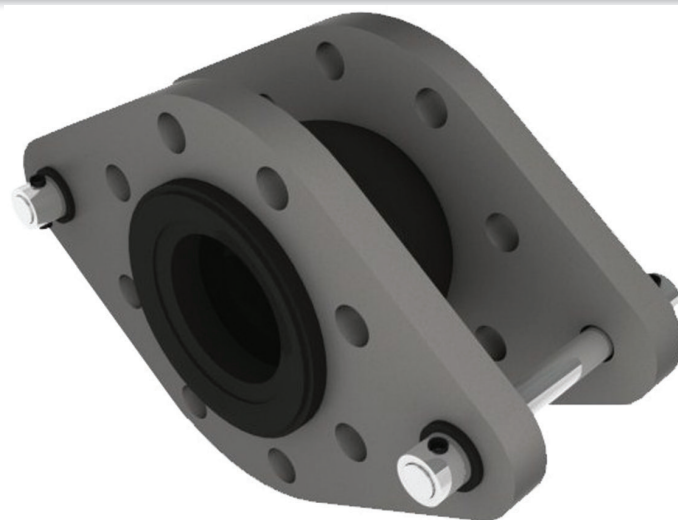

Size (mm)	Installed Length	Material Type	Temperature Limits °C	Part Number
32	130	Nylon Reinforced EPDM	-10 - 90	DST/032/PN16T
40	130	Nylon Reinforced EPDM	-10 - 90	DST/040/PN16T
50	130	Nylon Reinforced EPDM	-10 - 90	DST/050/PN16T
65	130	Nylon Reinforced EPDM	-10 - 90	DST/065/PN16T
80	130	Nylon Reinforced EPDM	-10 - 90	DST/080/PN16T
100	130	Nylon Reinforced EPDM	-10 - 90	DST/100/PN16T
125	130	Nylon Reinforced EPDM	-10 - 90	DST/125/PN16T
150	130	Nylon Reinforced EPDM	-10 - 90	DST/150/PN16T
200	130	Nylon Reinforced EPDM	-10 - 90	DST/200/PN16T
250	130	Nylon Reinforced EPDM	-10 - 90	DST/250/PN16T
300	On Request	Nylon Reinforced EPDM	-10 - 90	DST/300/PN16T
350	On Request	Nylon Reinforced EPDM	-10 - 90	DST/350/PN16T
400	On Request	Nylon Reinforced EPDM	-10 - 90	DST/400/PN16T

- DST D-Flex Pump Flexibles are installed to reduce Vibration and noise levels caused by “Plant” upon which they are fitted. These are suitable for use on systems carrying Chilled & Heating Water. Please see above for temperature & Pressure limit. DST D-Flex units are not suitable for use with Potable Water, Water with Oil additives, Compressed Air and Food Applications.
- DST D-Flex units are manufactured from spherical moulded EPDM, which is a soft compound to offer a high isolation efficiency and high noise absorbing properties.
- The D-flex units tied type has specially designed anti tamper tie bars. This will only allow the units to be installed at their optimal length and avoid elongation of the unit. These units rated to Maximum 10bar working pressure, 15bar test pressure
- The units are a full bore thus removing pressure drop problems.  
The EPDM rubber is nylon re-inforced, and has a steel wire re-inforced collar.
- Flanges BZP coated carbon steel PN16.
- D-Flex units have a 10 year design life and are warrantied for a period of 12 months from supply.
- DST D Flex units are stamped with Origin of Manufacture, Date Of Manufacture, Batch Number and Size.
- Please note no torsion forces should be applied to these units.
- DST Group Ltd also supply DIN 4809 Approved Pump Flexibles. Please contact our sales office for further information.

## Key Points

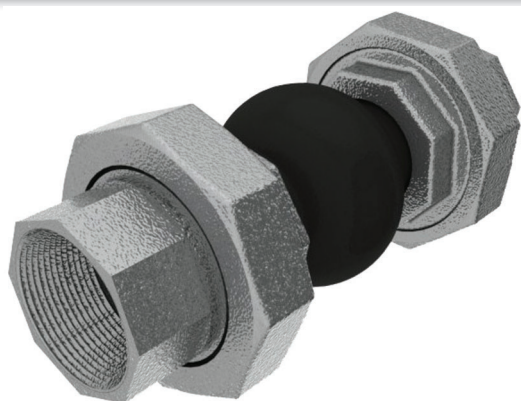

Unions: Carbon Steel

Nylon Re-inforced EPDM Rubber Body

Steel Reinforced Collars

Size (mm)	Installed Length	Material Type	Temperature Limits °C	Part Number
15	200	Nylon Reinforced EPDM	-10 - 90	PGS/015
20	200	Nylon Reinforced EPDM	-10 - 90	PGS/020
25	200	Nylon Reinforced EPDM	-10 - 90	PGS/025
32	200	Nylon Reinforced EPDM	-10 - 90	PGS/032
40	200	Nylon Reinforced EPDM	-10 - 90	PGS/040
50	200	Nylon Reinforced EPDM	-10 - 90	PGS/050

- DST D-Flex Pump Flexibles are installed to absorb vibration and noise levels caused by "Plant" upon which they are fitted. These are suitable for use on systems carrying Chilled & Heating Water. Please see above for temperature & Pressure limits.
- DST D Flex units are not suitable for use with Potable Water, Water with Oil additives, Compressed Air and Food Applications.
- DST D Flex Untied units should not be installed on pumps located on Inertia bases
- DST D-Flex units are manufactured from spherical moulded EPDM, which is a soft compound to offer a high isolation efficiency and high noise absorbing properties.
- The units are a full bore thus removing pressure drop problems. The EPDM rubber is nylon re-inforced, and has a steel wire re-inforced collar.
- Unions BZP coated carbon steel PN16.
- D-Flex units have a 10 year design life and are warrantied for a period of 12 months from supply.
- DST D Flex units are stamped with Origin of Manufacture, Date Of Manufacture, Batch Number and Size.
- Please note no torsion forces should be applied to these units.
- DST Group Ltd also supply DIN 4809 approved pump flexibles. Please contact our sales office for further information.



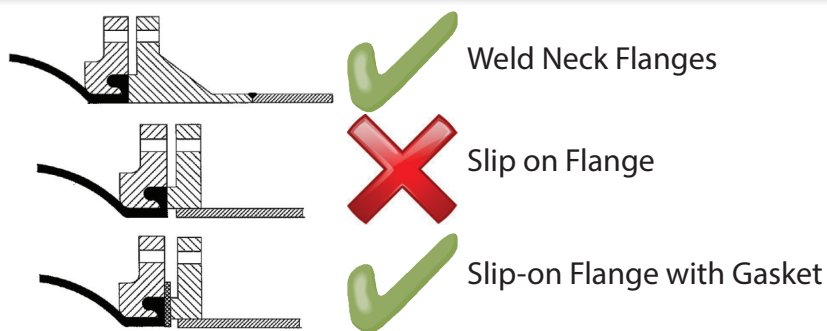

## A. Pre-installation Check

### 1. Selection

Prior to installation, check you have the right bellows for the particular duty.

Rubber bellows have temperature and pressure limitations. See DST GROUP LTD Data Sheets for your product.

All rubber bellows will extend under pressure. These pressure thrust forces can be very substantial at pressures above 2 bar and 65mm N.B. size. Unless the pipe work can be sufficiently anchored a tied bellows should be fitted.

### 2. Mating Flanges

We recommend the rubber bellows are mated up against full-bore weld neck flanges. If installed in this manner no additional gaskets are required.

We advise against using slip on or screwed flanges as mating flanges, as these can damage the rubber bellows. Once the sealing face has been damaged medium, will penetrate the reinforcement layers and destroy the integrity of the bellows.

If it is unavoidable to use this type of mating flange, a gasket must be installed. (This should be a hard gasket such as Klingerite and be at least 3mm thick) The gasket should reach the internal bore of the rubber bellows. Another option is to fill the gap of the slip on flange with weld and grind it flush.

### 3. Misalignment

Check the two mating flanges are parallel and that they are in line (maximum allowed offset is 5mm in any direction). The gap between flanges should be within +/- 5mm of the bellows neutral. Under no circumstances must the Pump Flexible be used to take up misalignment.

Ensure the pipework is adequately supported. The bellows must not support pipes or plant.

## B. Installation

### 1. Bolts

Bolts should be inserted from the bellows side. On some larger sizes this may not be possible. In that case a bolt of the exact length needs to be selected. An alternative is to use studding cut to length and fitted with a nut at both sides. This is important, as the bellows will increase in diameter under pressure. Even if there is space between the bolt and the bellows in an un-pressurised state, they may foul when pressurised. Bolts of the right diameter must be used to ensure correct alignment.

### 2. Alignment

Take care when inserting the bellows into the gap between the two mating flanges. Sharp edges can damage the sealing face of the rubber bellows. Before tightening the bolts, ensure the bellows sits evenly in its flange groove and does not get pinched between flanges. The sealing face of the bellows must be concentric with the sealing face of the mating flanges.

### 3. Tightening the Bolts

Great care has to be taken with the tightening of the flange bolts. Remember you are tightening against a rubber face. As with gaskets, over tightening will cause the joints to leak and it will damage the bellows. "Tighter is definitely not better!"

Tighten opposite bolts to get an even pressure all round (check the gap between the flanges).

Rubber will set and the bolts will have to be retightened after 24 hours.

### 4. Tie Bars

Once the bellows is fitted, ensure the tie bars are tight. All tie bars should be at equal length. When three or more tie bars are fitted it may be necessary to remove one tie bar to install the bellows. Ensure that washers are re-assembled in the right order and orientation.

## C. Taking Care of Rubber Bellows

1. Paint - Do not paint rubber bellows. The paint will attack the rubber. (This also applies to paint splatter).
2. Welding - Protect the rubber from weld spatter.
3. Lagging - Do not Lag rubber bellows on heating systems. The increased temperature will reduce the life of the bellows.
4. Tie Bar Check - Once the system is filled but not under pressure, check the tie bars are still tight (pipe work on springs may have dropped due to the weight of the water).  
  
Note: - tie bars should never be slackened off to reduce noise or vibration transmission, major damage to equipment may occur.
5. Water Treatment - Most bellows use an EPDM inner liner. EPDM is a proven material in heating and chilled water systems. It is resistant to glycol and to most chemicals used in water treatment, when used in normal concentrations. Suppliers of water treatment chemicals are reluctant to give information about their formulations, we cannot approve any specific chemical.

Always check with the chemical supplier that the additives are suitable for use with EPDM rubber. For other mediums check with DST Group Ltd for suitability.

## D. Best Practice

The following are only recommendations but if followed they will ensure proper installation and maximum service life of the rubber bellows.

1. Fitting - We recommend the use of stool pieces to align mating flanges and to ensure the correct gap. (They are available from DST Group Ltd).
2. System - When the bellows are installed on rotating equipment such as pumps to absorb noise and vibration, the pipe work either side of the bellows should be guided. This ensures the bellows move and not the pipe work thus acting as an acoustic break.
3. Restraint - The inherent resistance of pump flexibles is negligible in respect of calculations for anchorage points. Under pressure the D-Flex acts like a plunger, thus requiring to fix anchorage points or larger size D-Flex

## Key Points

- Suitable for Potable Water
- Suitable for High Temperatures
- PED Certified as Required
- Stainless Steel to all Wetted Areas

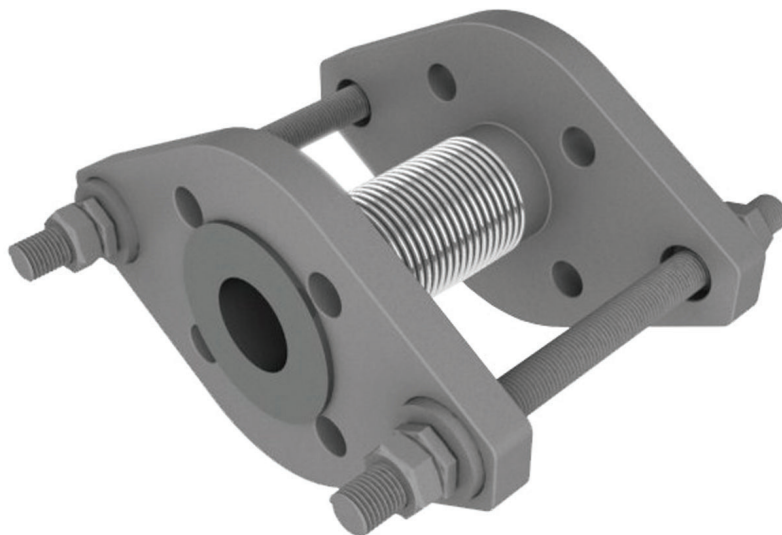

Size (mm)	Installed Length	Material Type	Temperature Limits °C	Part Number
32nb / 35cu	150	316 St/Steel to all Wet Areas	-10 - 200	FA3/032/PN16T
40nb / 42cu	150	316 St/Steel to all Wet Areas	-10 - 200	FA3/040/PN16T
50nb / 54cu	150	316 St/Steel to all Wet Areas	-10 - 200	FA3/050/PN16T
65nb / 67cu	150	316 St/Steel to all Wet Areas	-10 - 200	FA3/065/PN16T
80nb / 76cu	150	316 St/Steel to all Wet Areas	-10 - 200	FA3/080/PN16T
100nb / 108cu	150	316 St/Steel to all Wet Areas	-10 - 200	FA3/100/PN16T
125nb / 133cu	150	316 St/Steel to all Wet Areas	-10 - 200	FA3/125/PN16T
150nb / 159cu	150	316 St/Steel to all Wet Areas	-10 - 200	FA3/150/PN16T
200nb	150	316 St/Steel to all Wet Areas	-10 - 200	FA3/200/PN16T
250nb	On Request	316 St/Steel to all Wet Areas	-10 - 200	FA3/250/PN16T
300nb	On Request	316 St/Steel to all Wet Areas	-10 - 200	FA3/300/PN16T
350nb	On Request	316 St/Steel to all Wet Areas	-10 - 200	FA3/350/PN16T
400nb	On Request	316 St/Steel to all Wet Areas	-10 - 200	FA3/400/PN16T

DST D-Flex Pump Flexibles are installed to reduce Vibration and noise levels caused by “Plant” upon which they are fitted. These are suitable for use on systems carrying high temperature water or potable water systems. Please see above for temperature & Pressure limits. DST FA3 units are suitable for use with Potable Water, Water with Oil additives, Compressed Air and Food Applications.

## Material Specification

Connections:	Carbon Steel Drilled PN16 Van-stone Facings
Convolutions:	316 Stainless steel
Internal Sleeve:	316 Stainless steel
Tie Rods:	Carbon Steel
Hemispherical Washers:	Carbon Steel
Connecting Spool:	316 Stainless steel

The DST Type FA3 Pump Flexible is suitable for use on systems up to 200oC at 16 bar pressure. PED certification supplied dependant upon application.

All units are supplied at installation lengths and are pre stressed. Please note, DST Group Ltd can design and supply flexible connections to accommodate higher system temperatures / pressures. Please advise at time of enquiry / order the system temperature and pressure to allow correct selection of compensator.

## Key Points

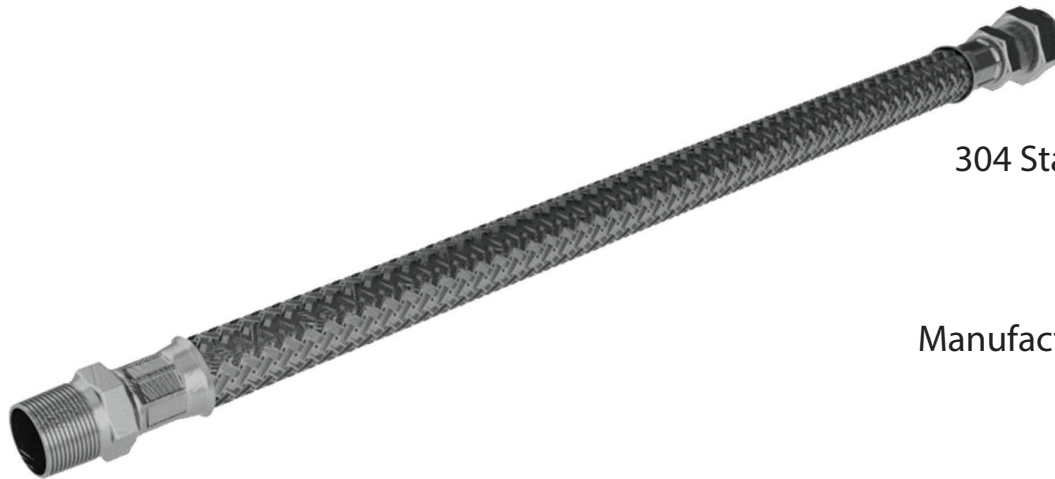

EPDM Rubber Core

304 Stainless Steel Overbraid

Hose WRAS Approved

Manufactured by DST in the UK

0 - 100oC @ 10 Bar

- Description - EPDM Rubber hose with 304 Stainless steel overbraid, swaged fittings to clients requirements.
- Testing - Hydrostatic batch test to minimum 20 bar cold. Test Certificate can be submitted upon request.
- Approvals - All hose is WRAS approved irrespective of application.
- Applications - Fan Coil Connections  
Radiant Panel Connections  
Tap Connections

## Fittings

**FIT001**  
Fixed Taper Male



**FIT004**  
Compression



**FIT002**  
Swivel Flat Face Female



**FIT005**  
Brass Standpipe



**FIT006**  
Flat Face 90° Female Elbow





## Key Points

- 321 Stainless Steel Core
- 304 Stainless Steel Overbraid
- Manufactured in the UK
- 0 - 100oC @ 10 Bar



- Description - 321 Stainless steel hose with 304 Stainless steel overbraid. Welded fittings to client requirements.
- Testing - Hydrostatic batch test to minimum 20 bar cold. Test Certificate can be submitted upon request.
- Applications -
  - Fan Coil Connections
  - Radiant Panel Connections
  - Tap Connections
  - Final Connections to Equipment

## Fittings

**FIT001**  
Fixed Taper Male



**FIT006**  
Flat Face 90° Female Elbow



**FIT002**  
Swivel Flat Face Female



**FIT007**  
Coned Face 90° Female Elbow



**FIT003**  
Swivel Coned Seat Female



## Key Points

10 Year Guarantee for EPDM. 2 Year Guarantee for Stainless Steel

25 Year Design Life

ISO9001 Quality System

Manufactured at DSTGroup Ltd in the UK

## Installation

Installation conditions as below must be adhered to, to ensure longevity of the product.

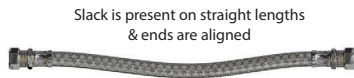
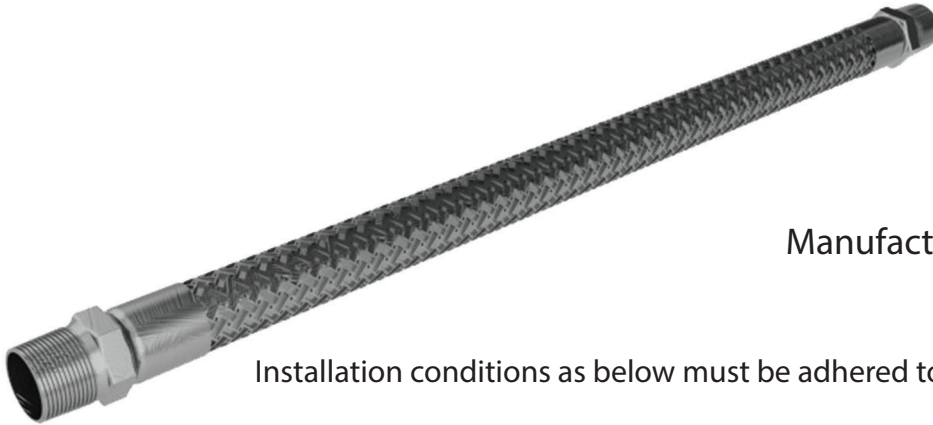

Avoid bending radius becoming too small by using elbows

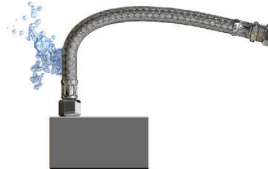

Hose is long enough to allow smooth curve



Do not bend hose too close to crimped end



Observe minimum bend radius

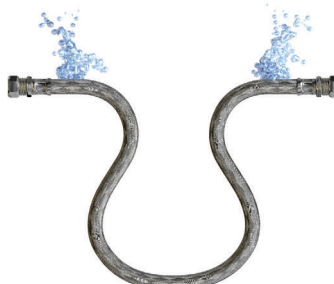

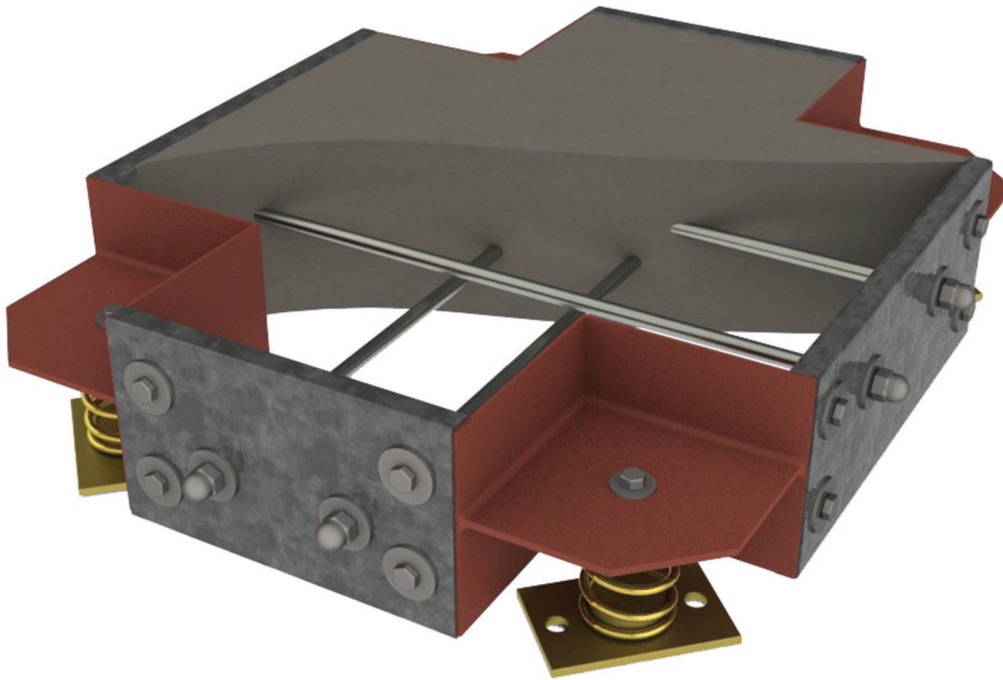

- DST Group Ltd Inertia Bases are supplied in a flat pack form to allow ease of installation on site, but can be delivered assembled if required. These are supplied with spring mounts and all fixings required to assemble the inertia base.
- DST Group Ltd can calculate the size of inertia base required. Please forward the pump details to DST Group Ltd Sales Office. As standard the DST Ltd Group Inertia Bases are supplied either 150mm or 300mm deep.
- DST Group Ltd Inertia Bases are supplied to provide no less than 1.5 : 1.0 Rate of inertia. As standard these bases are supplied with Springs.
- DST Group Ltd can, if required supply these bases fully assembled and cast with a 24N mix of concrete.
- DST Group Ltd advise that DST/\*\*\*/PN16T Tied DST D-Flex Pump Flexibles are used for isolating vibration from pump connections.

#### ■ Please Note:

Spring selection should be based upon equipment weight - DST Group Ltd can advise on selection at time of ordering.

Plant and pipework can be loaded unevenly, therefore different spring loads maybe required at different locations - Again DST Group Ltd can advise on selection at time of ordering.

Standard springs and housings are BZP with yellow passivate, othercoatings can be offered for external use. Please advise if your application is external.

Springs when fitted should be loaded equally, installing one spring before another will lead to uneven load.

### Key Points

Anti-Vibration Mount for Plant & Machinery

Enclosed Spring for Greater Stability.

Standard 25mm Deflection

Can be used in Conjunction with Inertia Bases



Model	Overall Width (mm)	Bolt Centres (mm)	Bolt Ø	Fixing Bolt Ø	Weight Range (Kg)	Deflection (mm)
DS/0-0050	130	110	M10	M12	11-23	25
DS/0-0080	130	110	M10	M12	18-37	25
DS/0-0130	130	110	M10	M12	30-60	25
DS/0-0200	130	110	M10	M12	45-91	25
DS/0-0300	130	110	M10	M12	68-137	25
DS/0-0500	130	110	M10	M12	114-228	25
DS/0-0630	130	110	M10	M12	148-296	25
DS/0-0800	130	110	M10	M12	182-364	25
DS/1-0150	173	148	M12	M12	34-69	25
DS/1-0200	173	148	M12	M12	45-91	25
DS/1-0300	173	148	M12	M12	68-137	25
DS/1-0500	173	148	M12	M12	114-228	25
DS/1-0750	173	148	M12	M12	170-341	25
DS/1-1000	173	148	M12	M12	227-455	25
DS/1-1200	173	148	M12	M12	273-546	25
DS/1-1400	173	148	M12	M12	318-637	25
DS/1-2-1700	173	148	M12	M12	386-773	25
DS/1-2-1900	173	148	M12	M12	432-864	25

### Please Note

Spring selection should be based upon equipment weight - DST Group Ltd can advise on selection at time of ordering.

Plant and pipework can be loaded unevenly, therefore different spring loads may be required at different locations - DST Group Ltd can advise on selection at time of ordering.

Standard housing is powder coated, the standard spring is BZP, other coatings can be offered for external use. Please advise if your application is external.

Springs when fitted should be loaded equally, installing one spring before another will lead to uneven load.



## Key Points

- 2 Year Guarantee
- 25 Year Design Life
- ISO9001 Quality System
- Manufactured in the UK

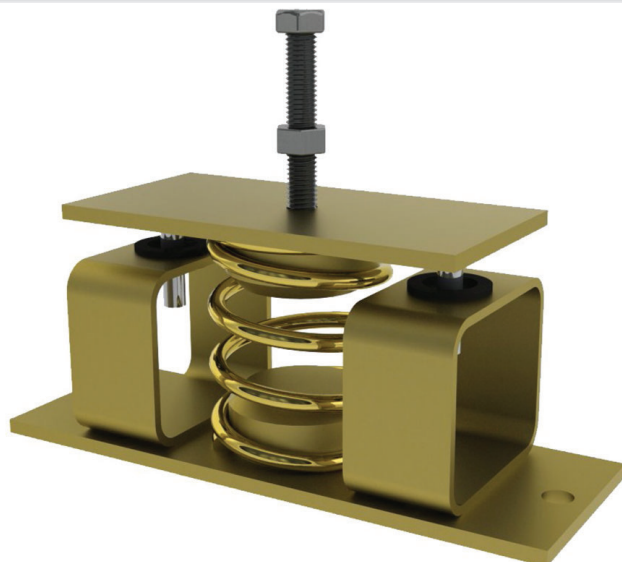

Model	Overall Width (mm)	Bolt Centres (mm)	Bolt Ø	Fixing Bolt Ø	Weight Range (Kg)	Deflection (mm)
RS/0-0050	230	198	M12	M12	11-23	30
RS/0-0080	230	198	M12	M12	18-37	30
RS/0-0130	230	198	M12	M12	30-60	30
RS/0-0200	230	198	M12	M12	45-91	30
RS/0-0300	230	198	M12	M12	68-137	30
RS/0-0500	230	198	M12	M12	114-228	30
RS/0-0630	230	198	M12	M12	148-287	30
RS/0-0800	230	198	M12	M12	182-364	30
RS/0-1100	230	198	M12	M12	250-500	30
RS/1-0425	230	198	M12	M12	97-194	30
RS/1-0600	230	198	M12	M12	136-273	30
RS/1-0750	230	198	M12	M12	170-341	30
RS/1-1000	230	198	M12	M12	227-455	30
RS/1-1400	230	198	M12	M12	318-637	30
RS/1-1700	230	198	M12	M12	386-773	30
RS/1-2000	230	198	M12	M12	455-910	30
RS/1-2400	230	198	M12	M12	545-1091	30

## Please Note:

Spring selection should be based upon equipment weight - DST Group Ltd can advise on selection at time of ordering.

Plant and pipework can be loaded unevenly, therefore different spring loads may be required at different locations - DST Group Ltd can advise on selection at time of ordering.

Standard springs and housings are BZP with yellow passivate, other coatings can be offered for external use. Please advise if your application is external.

Springs when fitted should be loaded equally, installing one spring before another will lead to uneven load.

## Key Points

2 Year Guarantee

25 Year Design Life

ISO9001 Quality System

Manufactured in the UK

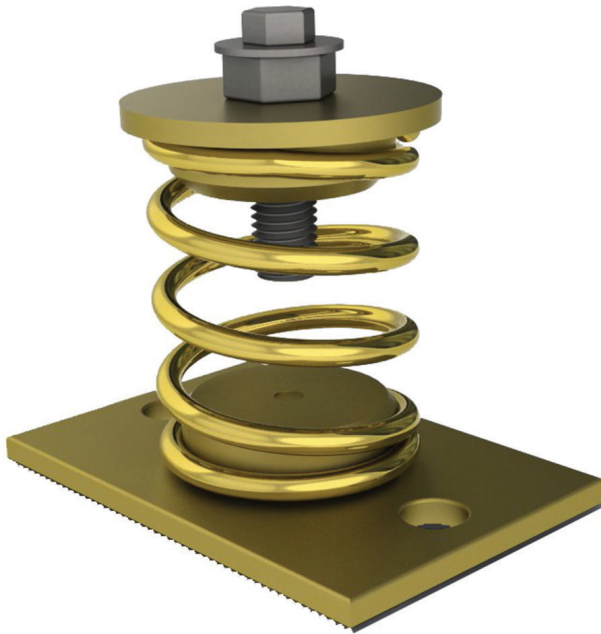

Model	Overall Width (mm)	Bolt Centres (mm)	Bolt Ø	Fixing Bolt Ø	Weight Range (Kg)	Deflection (mm)
OS/0-0050	130	92	M12	M10	11-23	30
OS/0-0080	130	92	M12	M10	18-37	30
OS/0-0130	130	92	M12	M10	30-60	30
OS/0-0200	130	92	M12	M10	45-91	30
OS/0-0300	130	92	M12	M10	68-137	30
OS/0-0500	130	92	M12	M10	114-228	30
OS/0-0630	130	92	M12	M10	148-287	30
OS/0-0800	130	92	M12	M10	182-364	30
OS/0-1100	130	92	M12	M10	250-500	30
OS/1-0425	165	120	M12	M12	97-194	30
OS/1-0600	165	120	M12	M12	136-273	30
OS/1-0750	165	120	M12	M12	170-341	30
OS/1-1000	165	120	M12	M12	227-455	30
OS/1-1400	165	120	M12	M12	318-637	30
OS/1-1700	165	120	M12	M12	386-773	30
OS/1-2000	165	120	M12	M12	455-910	30
OS/1-2400	165	120	M12	M12	545-1091	30

### Please Note:

Spring selection should be based upon equipment weight - DST Group Ltd can advise on selection at time of ordering.

Plant and pipework can be loaded unevenly, therefore different spring loads may be required at different locations - DST Group Ltd can advise on selection at time of ordering.

Standard springs and housings are BZP with yellow passivate, other coatings can be offered for external use. Please advise if your application is external.

Springs when fitted should be loaded equally, installing one spring before another will lead to uneven load.

## Key Points

- Suitable for isolating vibration from packaged units
- Pressurisation Units
- Please advise the weight and plant footprint requiring isolation for mount recommendations



Weight (Kg)	Material Type	Hole Tapping Size	Dimensions (mm) Width x Height	Part Number
150	Neoprene Commercial Grade Black Rubber	M10	75 x 32	CMC/150/M
300	Neoprene Commercial Grade Black Rubber	M12	90 x 40	CMC/300/M

## Key Points

- Isolating vibration from Pipework
- Please advise the weight of plant requiring isolation for hanger recommendations

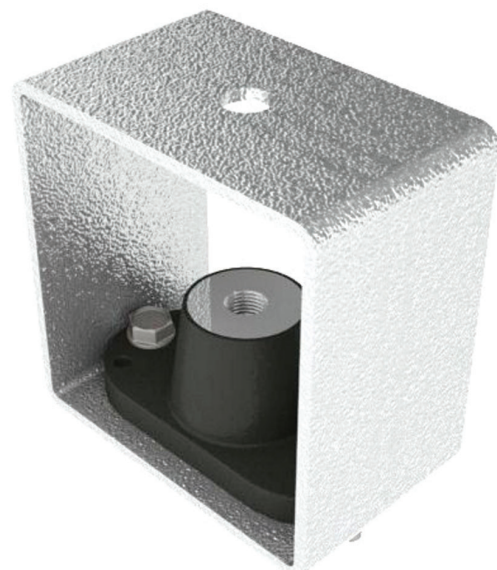

Weight (Kg)	Material Type	Hole Tapping Size	Dimensions (mm) Width x Height	Part Number
150	Neoprene Commercial Grade Black Rubber	M10	75 x 32	CMC/150/M
300	Neoprene Commercial Grade Black Rubber	M12	90 x 40	CMC/300/M

## Please Note:

Mount selection should be based upon equipment weight - DST Group Ltd can advise on selection at time of ordering.

Plant and pipework can be loaded unevenly, therefore different mount loads maybe required at different locations - Again DST Group Ltd can advise on selection at time of ordering.

Mounts when fitted should be loaded equally, installing one mount before another will lead to uneven load.

## Key Points

2 Year Guarantee

25 Year Design Life

ISO9001 Quality System

Manufactured in the UK



Model	Overall Width (mm)	Bolt Centres (mm)	Bolt Ø	Fixing Bolt Ø	Weight Range (Kg)	Deflection (mm)
SHO S/0-0050	150	180	M12	M12	11-23	30
SHO S/0-0080	150	180	M12	M12	18-37	30
SHO S/0-0130	150	180	M12	M12	30-60	30
SHO S/0-0200	150	180	M12	M12	45-91	30
SHO S/0-0300	150	180	M12	M12	68-137	30
SHO S/0-0500	150	180	M12	M12	114-228	30
SHO S/0-0630	150	180	M12	M12	148-287	30
SHO S/0-0800	150	180	M12	M12	182-364	30
SHO S/0-1100	150	180	M12	M12	250-500	30
SHO S/1-0425	250	250	M16	M16	97-194	30
SHO S/1-0600	250	250	M16	M16	136-273	30
SHO S/1-0750	250	250	M16	M16	170-341	30
SHO S/1-1000	250	250	M16	M16	227-455	30
SHO S/1-1400	250	250	M16	M16	318-637	30
SHO S/1-1700	250	250	M16	M16	386-773	30
SHO S/1-2000	250	250	M16	M16	455-910	30
SHO S/1-2400	250	250	M16	M16	545-1091	30

### Please Note:

Spring selection should be based upon equipment weight - DST Group Ltd can advise on selection at time of ordering.

Plant and pipework can be loaded unevenly, therefore different spring loads may be required at different locations - DST Group Ltd can advise on selection at time of ordering.

Standard springs and housings are BZP with yellow passivate, other coatings can be offered for external use. Please advise if your application is external.

Springs when fitted should be loaded equally, installing one spring before another will lead to uneven load.



## Key Points

- 2 Year Guarantee
- 25 Year Design Life
- ISO9001 Quality System
- Manufactured in the UK



Model	Overall Width (mm)	Bolt Centres (mm)	Bolt Ø	Fixing Bolt Ø	Weight Range (Kg)	Deflection (mm)
SHOS/0/P-0050	150	180	M12	M12	11-23	30
SHOS/0/P-0080	150	180	M12	M12	18-37	30
SHOS/0/P-0130	150	180	M12	M12	30-60	30
SHOS/0/P-0200	150	180	M12	M12	45-91	30
SHOS/0/P-0300	150	180	M12	M12	68-137	30
SHOS/0/P-0500	150	180	M12	M12	114-228	30
SHOS/0/P-0630	150	180	M12	M12	148-287	30
SHOS/0/P-0800	150	180	M12	M12	182-364	30
SHOS/0/P-0110	150	180	M12	M12	250-500	30
SHOS/1/P-0425	250	250	M16	M16	97-194	30
SHOS/0/P-0600	250	250	M16	M16	136-273	30
SHOS/1/P-0750	250	250	M16	M16	170-341	30
SHOS/1/P-1000	250	250	M16	M16	227-455	30
SHOS/1/P-1400	250	250	M16	M16	318-637	30
SHOS/1/P-1700	250	250	M16	M16	386-773	30
SHOS/1/P-2000	250	250	M16	M16	455-910	30
SHOS/1/P-2400	250	250	M16	M16	545-1091	30

## Please Note:

Spring selection should be based upon equipment weight - DST Group Ltd can advise on selection at time of ordering.

Plant and pipework can be loaded unevenly, therefore different spring loads maybe required at different locations - DST Group Ltd can advise on selection at time of ordering.

Standard springs and housings are BZP with yellow passivate, other coatings can be offered for external use. Please advise if your application is external.

Springs when fitted should be loaded equally, installing one spring before another will lead to uneven load.

# Contamination Control

## RapidVent Air & Dirt Separator

### Key Points

Microbubble Type

Flanged PN16

10 Bar Working Pressure

110 Degrees C



Flanged Air and Dirt Remover with internals designed to create a large surface area for water to flow over causing coalescence. The coalescent effect releases microbubble of air and dirt which are able to rise to the top of the unit to be vented in the case of air, or sink to the base of the unit to be collect in the base of the unit and drained at a later stage.

Pipe Size	Face to Face	Body Diameter	Height	Flange	Flow Rate @ 1.5m/s
50mm	430mm	168mm	589mm	PN16	12m <sup>3</sup> /h
65mm	430mm	168mm	589mm	PN16	20m <sup>3</sup> /h
80mm	490mm	220mm	780mm	PN16	28m <sup>3</sup> /h
100mm	490mm	220mm	780mm	PN16	47m <sup>3</sup> /h
125mm	630mm	325mm	952mm	PN16	70m <sup>3</sup> /h
150mm	630mm	325mm	952mm	PN16	100m <sup>3</sup> /h
200mm	810mm	410mm	1266mm	PN16	175m <sup>3</sup> /h

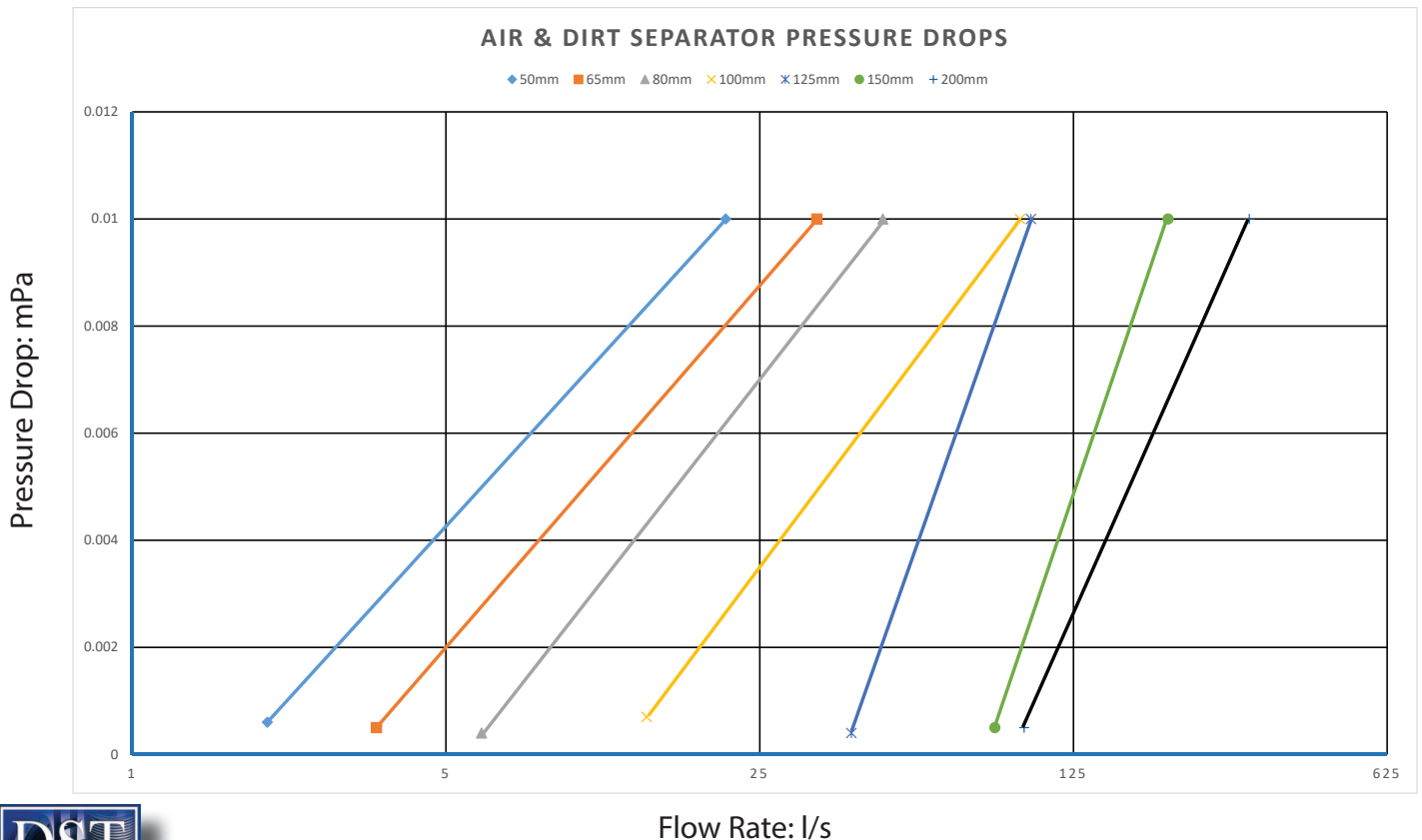

## RapidVent Air & Dirt Separators Selection & Installation

### Selection

DST offer a complete range of air and dirt separators. Check that the correct separator has been selected for the operating conditions that exist. To enable efficient air and dirt removal the separator should be line size.

### Location

1. Micro Bubbles are easily released from circulating water where the highest temperature and lowest pressure conditions occur in the system
2. The separators should normally be fitted where water is at the highest temperature and the lowest pressure available.
3. The examples shown below are typical installation layouts, but other acceptable and efficient locations for the separator exist.
4. When selecting the position for the separator please be aware that pressure also has a major effect on the release of micro bubbles.
5. For temperatures normally found within heating systems a one metre drop in head pressure is equivalent to a rise in temperature of four degrees centigrade.
6. Where lower temperatures are involved in cooling applications system pressure becomes the determining factor of the position of the separator.
7. DST air and dirt separators should be installed in horizontal pipework, the direction of flow is optional.

### Installation

1. Automatic air vent and isolation valve should be fitted to the top of the separator,
2. Commissioning valve on the side
3. Drain valve on the base as shown in the illustration at the top of this page.
4. To protect the automatic air vent the isolation valve should be closed prior to flushing the system.
5. Flexible hose or fixed pipework should be installed to enable dirty water to be drained to a convenient safe place.

### Maintenance

1. Automatic air vent should be checked periodically to ensure it is functioning correctly.
2. To prevent sediment build up and maintain efficiency the separator should be flushed at regular intervals.
3. Dirt sludge and solid particles can be removed by opening the drain valve on the base of the separator until the water runs clear.

**WARNING To prevent scalding safe practice must be observed when venting hot water at pressure.**

## Key Points



Steel Construction

Supplied With Tundish & All Valves

Powder Coated Finish

Wall Mounting Brackets Fitted

Vessel for measuring accurately the amount of chemical dose for a system, and then allowing water to be flushed through it to complete the dosing cycle.

Available in 3.5, 6, 11 & 18 Litre Versions

Rated 10 Bar at 120 Deg C.

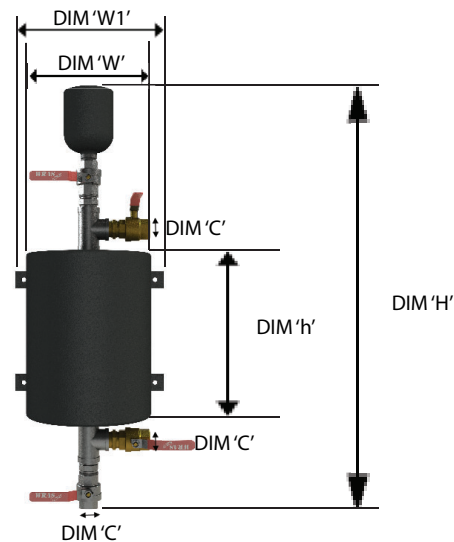

SIZE	DIM 'H'	DIM 'h'	DIM 'W'	DIM 'W1'	DIM 'C'	Material
<b>3.5</b>	770mm	186mm	168mm	315mm	1"	Mild Steel
<b>6L</b>	770mm	250mm	210mm	315mm	1"	Mild Steel
<b>11L</b>	800mm	365mm	220mm	315mm	1"	Mild Steel
<b>18L</b>	1030mm	590mm	220mm	315mm	1"	Mild Steel



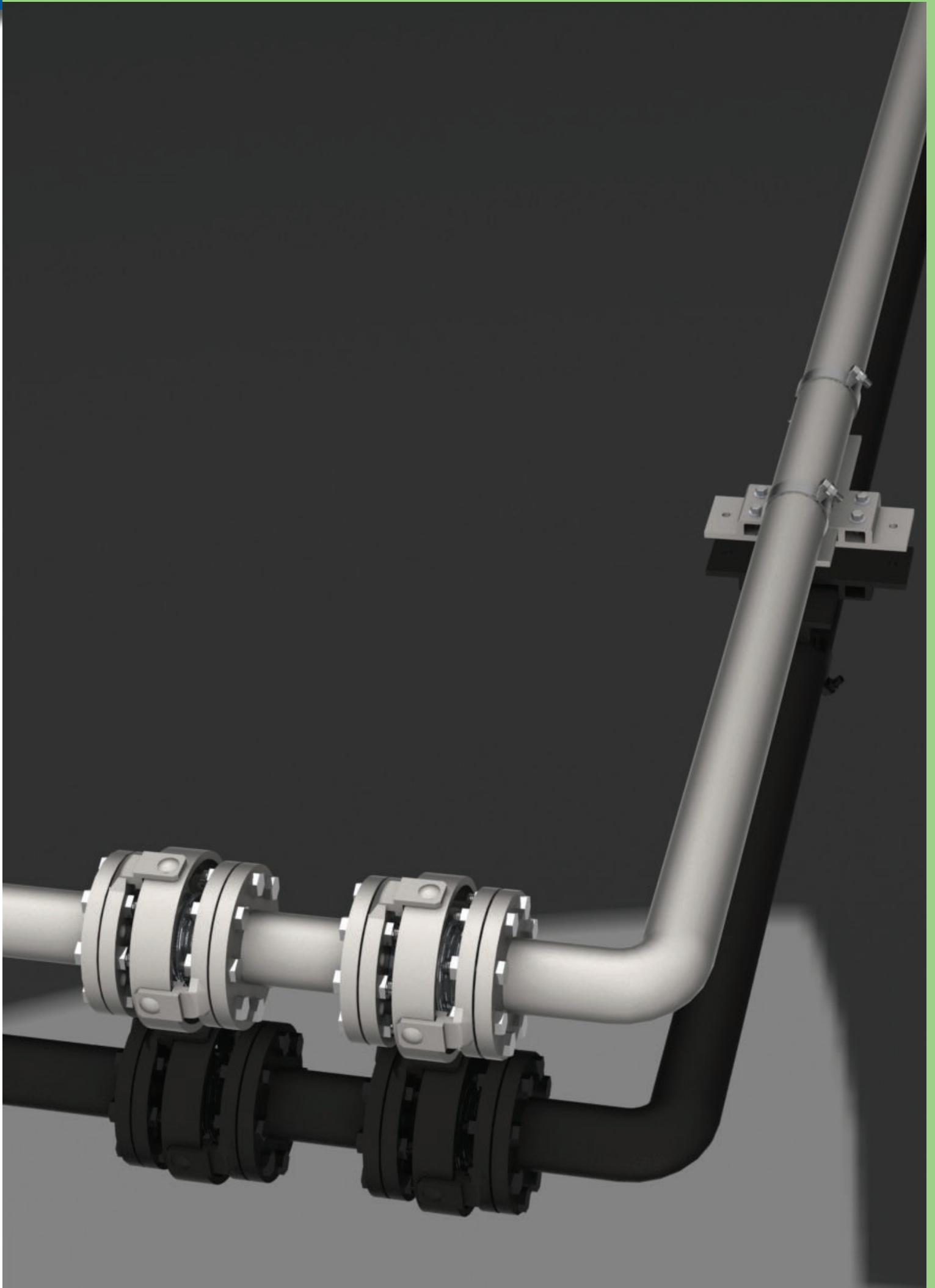

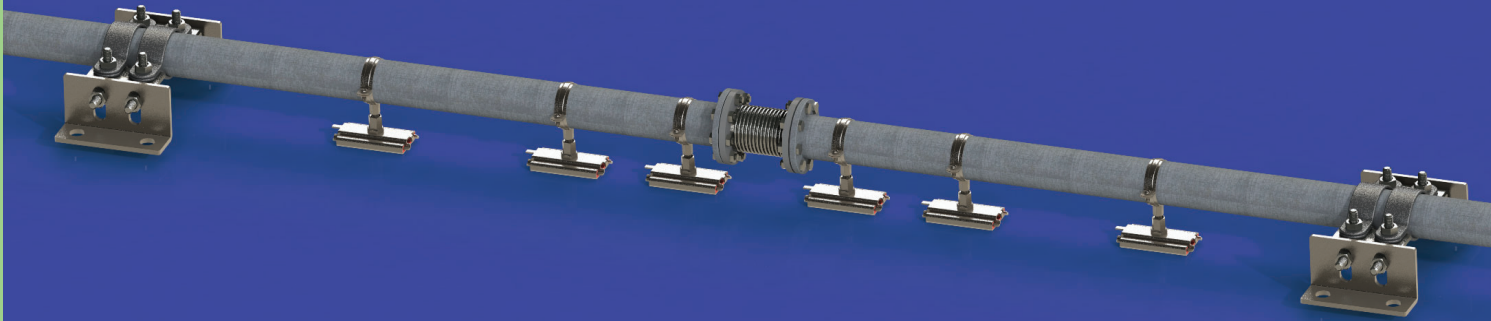

It is an accepted rule of physics that a material, when subjected to a change of temperature, will expand or contract directly related to the temperature. Pipework is therefore subject to the same principal.

Factors to be considered when calculating the amount of expansion are as follows:

1. The amount of temperature change – based upon the lowest ambient temperature.
2. The overall length of pipe upon which calculations are to be based.
3. The co-efficient of expansion for the required material.

### Carbon Steel Pipes

The co-efficient of expansion for carbon steel is:  $0 - 100^{\circ}\text{C} = \text{Cof}\Delta 1.11$   
 (These Co-efficients can be used for standard stainless steels)  $101^{\circ}\text{C} + = \text{Cof}\Delta 1.21$

### Copper Pipes

Copper expands at a 50% higher rate, the equation would be:  $0 - 100^{\circ}\text{C} = \text{Cof}\Delta 1.11 \times 1.5$   
 (These Co-efficients can be used for thin wall stainless steels)  $101^{\circ}\text{C} + = \text{Cof}\Delta 1.21 \times 1.5$

### Plastic Pipes

The rate of expansion for plastics differs between materials and manufacturers; it is always advisable to check the rate of thermal expansion with the manufacturer.

The following table shows the expansion ratio in mm/m. This can be used instead of calculating individual sections of pipe.

Expansion Ratio of Pipe			
Steam or Water Temperature		Expansion in mm/m	
$^{\circ}\text{C}$	$^{\circ}\text{F}$	Steel Pipes	Copper Pipes
0	0	0	0
65	149	0.72	1.08
82	180	0.91	1.37
120	248	1.45	2.18
134	272	1.62	2.43
144	290	1.74	2.61
152	305	1.83	2.76
170	338	2.05	3.09
184	363	2.23	3.34
198	388	2.39	n/a
205	405	2.48	n/a
217	422	2.62	n/a
226	439	2.73	n/a

By using the table above we can extract the movement ratio in mm/m and multiply by the total length of pipework:

#### Example 1

To calculate the expansion on a 75m length of carbon steel pipe passing 10bar steam:

Temperature Rise =  $184^{\circ}\text{C}$   
 Expansion in mm/m =  $2.23\text{mm/m}$   
 Pipe Length =  $75\text{m}$   
 Total Expansion =  $75 \times 2.23 = 167.5\text{mm}\Delta$

#### Example 2

To calculate the expansion on a 25m length of copper pipe supplying LTHW at  $82^{\circ}\text{C}$ :

Temperature Rise =  $82^{\circ}\text{C}$   
 Expansion in mm/m =  $1.37\text{mm/m}$   
 Pipe Length =  $25\text{m}$   
 Total Expansion =  $25 \times 1.37 = 34.25\text{mm}\Delta$

Pipework systems have various changes in direction within itself. As this occurs pipework systems should have some natural flexibility within it. The following pages will help the engineer use the changes in direction to naturally flex the expansion that will occur.

Expansion within hot pipework is always present. Expansion rates of 74.4mm over a length of 30mtrs steel pipework carrying steam at 205°C needs channelling somewhere.

Items which need to be addressed by the engineer:

- A. Method of pipework bracketing to allow natural flexibility to occur.
- B. Pipework material
- C. Pipework nominal size.
- D. Location and layout of pipework including length.
- E. Minimum and maximum temprature of pipework, media and ambient. Applicable to ambient temperatures 0°C and under.
- F. Working and test pressure of pipework media
- G. Connection points to plant etc.
- H. Structure of building.

Once we have addressed all these items then we can look at solutions.

To help take into account the above items, the engineer should use pipework anchors. Pipework anchors can separate large complicated pipework systems into smaller more manageable systems.

Positioning the anchors so an offset occurs between the anchors could naturally compensate the expansion.

The forces imposed upon an anchor is primarily made up from two areas:

- A. Force to Deflect pipework offset.
- B. Frictional force due to pipework bracketry.

Forces subjected onto the anchor positions can be calculated using the following formulae:-

$$F = \frac{24IX}{L^3} \quad \text{For carbon steel pipes.}$$

$$F = \frac{8.4IX}{L^3} \quad \text{For copper pipes.}$$

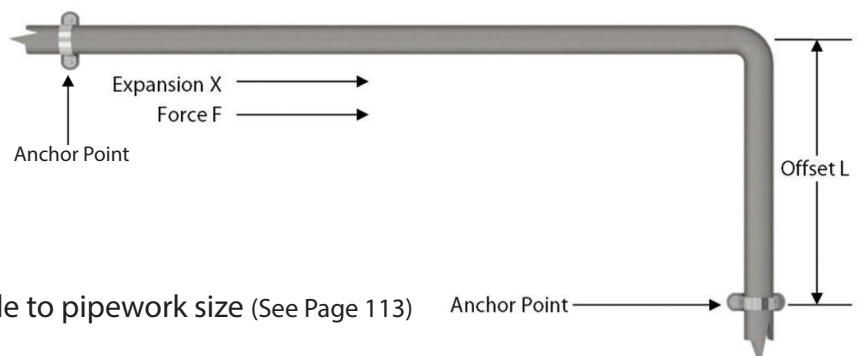

F = Force in Newtons

I = Moment of Inertia in cm<sup>4</sup> Applicable to pipework size (See Page 113)

X = Expansion in mm

L = Length of offset in metres (shortest length)

You will also need to add to this result the force is encountered via frictional resistance of pipework bracketry on the pipework.

Examples of frictional resistance can be calculated using the following formulae:-

$$F = L \times 15 \times \frac{I/D}{25}$$

F = Force in Newtons

L = Length of pipework (longest length)

15 = 15 Newtons which is the frictional resistance based on the use of a DST-253 Slide Guide

I/D = Inside diameter of the pipework



## Example 1

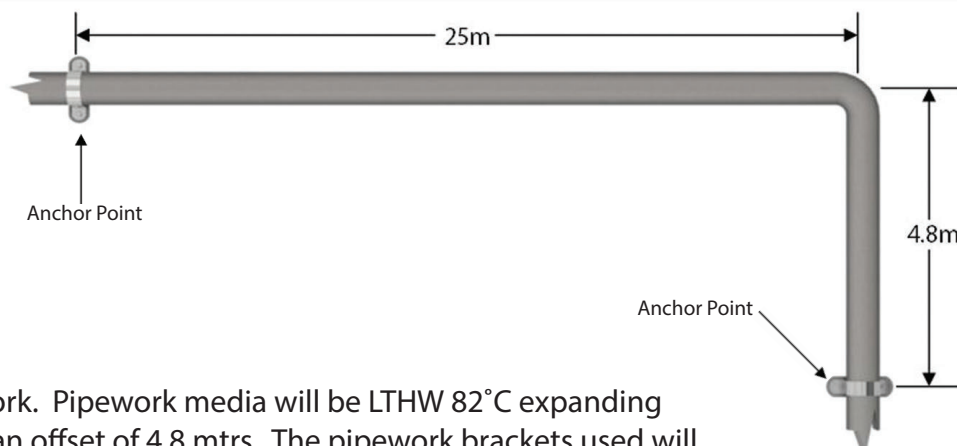

25 mtrs 65NB Steel Pipework. Pipework media will be LTHW 82°C expanding (0.91 x 25) 22.75mm with an offset of 4.8 mtrs. The pipework brackets used will be DST 253 Slide Guides.

$$(A) \quad \frac{F = 24IX}{L^3} \quad \frac{F = 24 \times 54.5 \times 22.75}{112.68} = 264.08 \text{ Newtons}$$

(B) We also need to add the force to overcome frictional resistance:

$$F = L \times 15 \times \frac{I/D}{25} \quad \frac{F = 25 \times 15 \times 65}{25} = 937.5 \text{ Newtons}$$

Therefore the total anchor load will be:

$$(A) = 264.08 + (B) = 937.50 = 1201.58 \text{ Newtons}$$

## Example 2

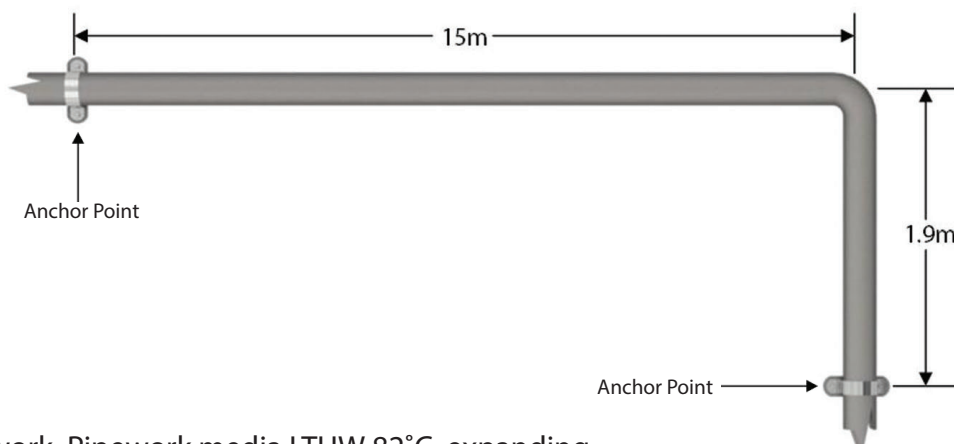

42cu (table Y) copper pipework. Pipework media LTHW 82°C. expanding (1.37 x 15) = 20.55mm The pipework brackets used will be DST Group Ltd Surefix UL pipe clip + DST Ballhanger.

$$(A) \quad \frac{F = 8.4IX}{L^3} \quad \frac{F = 8.4 \times 3.93 \times 20.55}{6.86} = 98.89 \text{ Newtons}$$

(B) We also need to add the force to overcome frictional resistance.

$$F = L \times 30 \times \frac{I/D}{25} \quad \frac{F = 15 \times 30 \times 42}{25} = 675.00 \text{ Newtons}$$

Therefore the total anchor load will be:

$$(A) = 98.89 + (B) = 675.00 = 773.89 \text{ Newtons}$$

If natural offsets occur within the design of the pipework system, it may be possible to utilise this to take up thermal expansion by using the natural flexibility of the pipework. The tables below show the minimum length of offset required for steel and copper pipes subjected to thermal expansion.

A system utilising an offset to take up expansion can be bracketed utilising most common types of brackets including drop rods, sliding and rolling supports. For more information, please see the first section of this product guide for more details.

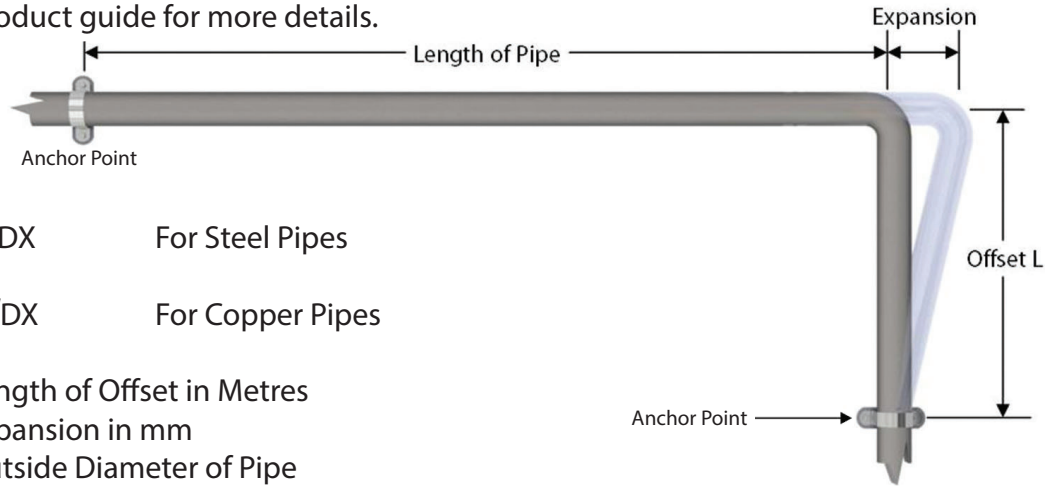

Offset L = 0.1  $\sqrt{DX}$  For Steel Pipes

Offset L = 0.06  $\sqrt{DX}$  For Copper Pipes

- L = Length of Offset in Metres
- X = Expansion in mm
- D = Outside Diameter of Pipe

Table Showing Single Offset For Steel Pipes (Without cold draw)

Expansion X	Pipe Nominal Bore											
	15nb	20nb	25nb	32nb	40nb	50nb	65nb	80nb	100nb	125nb	150nb	200nb
1mm	0.46	0.52	0.58	0.65	0.69	0.77	0.87	0.94	1.09	1.18	1.29	1.48
3mm	0.79	0.90	1.01	1.12	1.20	1.34	1.51	1.63	1.84	2.05	2.24	2.57
5mm	1.02	1.16	1.30	1.45	1.55	1.73	1.95	2.11	2.39	2.65	2.89	3.32
10mm	1.45	1.64	1.84	2.04	2.19	2.44	2.75	2.98	3.38	3.74	4.09	4.69
15mm	1.77	2.01	2.25	2.51	2.68	3.00	3.38	3.65	4.13	4.58	5.01	5.74
20mm	2.05	2.32	2.61	2.89	3.09	3.46	3.89	4.22	4.77	5.90	5.79	6.63
30mm	2.51	2.84	3.19	3.54	3.79	4.24	4.77	5.16	5.85	6.48	7.09	8.12
40mm	2.89	3.29	3.69	4.09	4.38	4.89	5.51	5.97	6.75	7.48	8.19	9.38
60mm	3.55	4.02	4.02	5.01	5.36	6.00	6.75	7.31	8.27	9.17	10.04	11.49
80mm	4.09	4.65	4.65	5.79	6.19	6.92	7.79	8.43	9.54	10.58	11.59	13.27
100mm	4.58	5.19	5.19	6.48	6.92	7.75	8.71	9.43	10.67	11.83	12.96	14.83

Table Showing Single Offset For Copper Pipes (Without cold draw)

Expansion X	Pipe Nominal Bore											
	15nb	22nb	28nb	35nb	42nb	54nb	67nb	76nb	108nb	133nb	159nb	219nb
1mm	0.23	0.28	0.32	0.35	0.39	0.44	0.49	0.52	0.62	0.69	0.76	0.89
3mm	0.40	0.49	0.55	0.61	0.67	0.76	0.85	0.91	1.08	1.19	1.31	1.54
5mm	0.52	0.63	0.71	0.79	0.87	0.99	1.09	1.17	1.39	1.55	1.69	1.99
10mm	0.73	0.89	1.00	1.12	1.22	1.39	1.55	1.65	1.97	2.19	2.39	2.81
15mm	0.90	1.09	1.23	1.37	1.52	1.71	1.90	2.02	2.41	2.68	2.93	3.44
20mm	1.03	1.26	1.42	1.59	1.74	1.97	2.19	2.34	2.78	3.09	3.38	3.97
30mm	1.28	1.54	1.74	1.94	2.12	2.41	2.69	2.86	3.42	3.79	4.14	4.86
40mm	1.47	1.78	2.01	2.24	2.45	2.79	3.11	3.31	3.98	4.38	4.78	5.62
60mm	1.80	2.18	2.46	2.75	3.01	3.42	3.80	4.05	4.83	5.36	5.86	6.88
80mm	2.07	2.52	2.84	3.17	3.48	3.94	4.39	4.68	5.58	6.19	6.77	7.94
100mm	2.32	2.81	3.17	3.55	3.89	4.41	4.91	5.23	6.24	6.92	7.56	8.88

Example of how cold draw can be used:

30m of 100NB Steel Pipework

82°C LTHW

$\Delta = L \times T \times C \text{ of } \Delta$

$$\Delta = 30 \times 82 \times 1.11 = 27.3\text{mm } \Delta$$

27.3mm will require a 5.85m Offset (According to the table on the previous page)

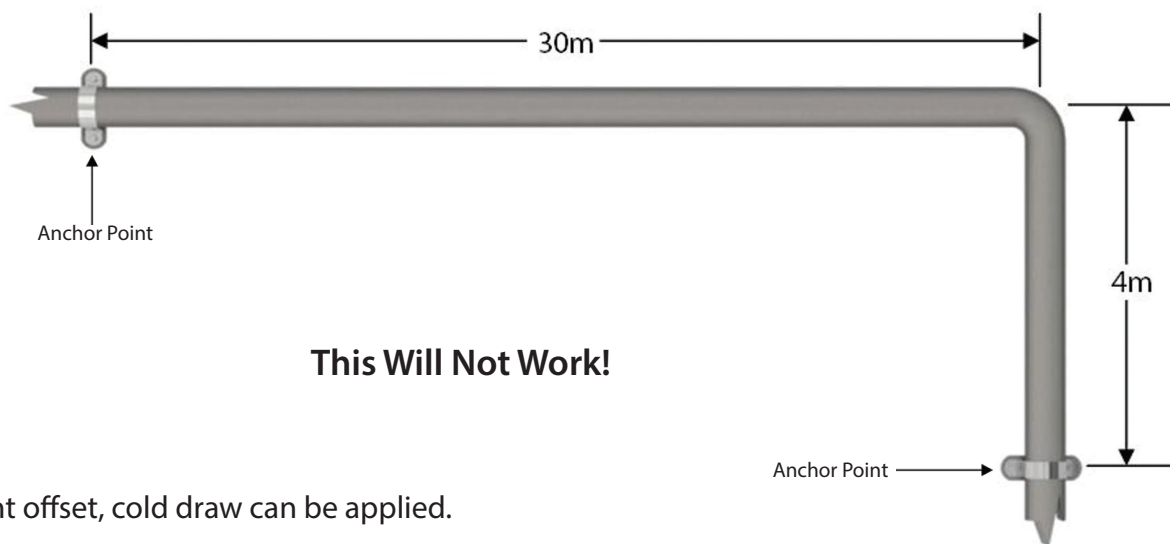

If there is insufficient offset, cold draw can be applied.

Standard practice would be to reduce the length of the pipework or "COLD DRAW" it by 50% of the expected expansion.

Once applied, the pipework is in effect pre-stressed, allowing the offset to take up twice the amount of expansion.

Therefore, if 27.3mm of expansion will require a 5.85m Offset, with 50% cold draw, the expansion is effectively 13.65mm, therefore the offset required will be 3.94m.

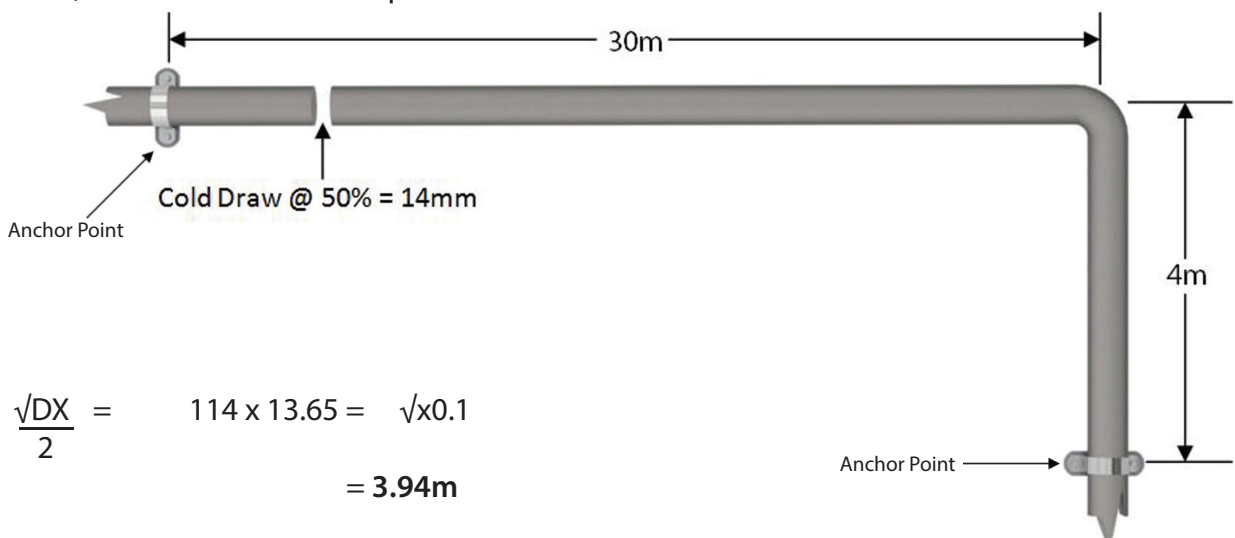

$$\text{Offset } L = 0.1 \frac{\sqrt{DX}}{2} = 114 \times 13.65 = \sqrt{x0.1} = 3.94\text{m}$$

If the use of expansion devices is not suitable for the application, you may be able to utilise expansion loops to take up the thermal expansion of the pipework. Loops should always be positioned in the middle of a pipe run, with anchors at each end of the run.

Loops are often useful on a drop rod system as axial expansion devices cannot be used on such a system. If you design a loop into a pipework system, we strongly recommend the use of DST Ball Hangers to aid movement.

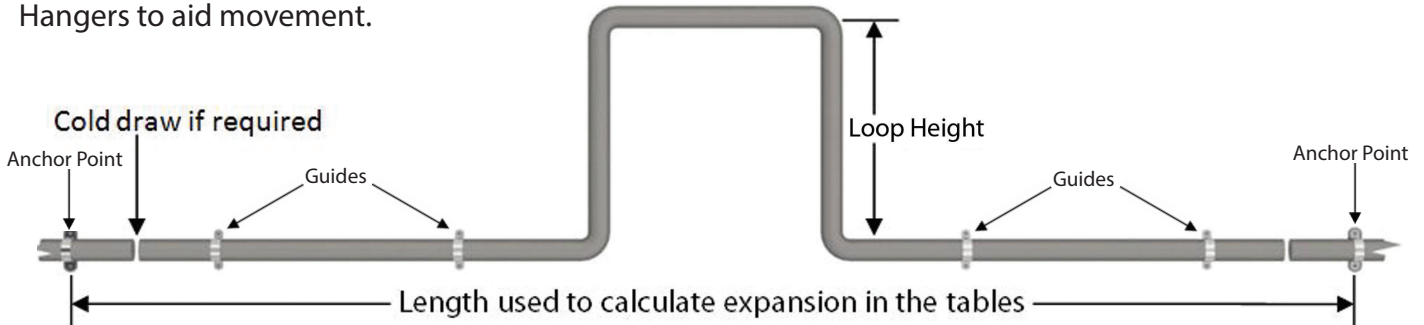

Offset  $L = 0.1 \frac{DX}{2}$  For Steel Pipes  $L = \text{Length of Offset in Metres}$   
 $X = \text{Expansion in mm}$   
 $D = \text{Outside Diameter of Pipe}$

Offset  $L = 0.06 \frac{DX}{2}$  For Copper Pipes

Table Showing Single Offset For Steel Pipes (Without cold draw)

Expansion X	Pipe Nominal Bore											
	15nb	20nb	25nb	32nb	40nb	50nb	65nb	80nb	100nb	125nb	150nb	200nb
1mm	0.32	0.36	0.41	0.46	0.49	0.55	0.62	0.67	0.75	0.84	0.92	1.05
3mm	0.56	0.64	0.71	0.79	0.85	0.95	1.07	1.15	1.31	1.45	1.59	1.82
5mm	0.72	0.82	0.92	1.02	1.09	1.22	1.38	1.49	1.69	1.87	2.05	2.35
10mm	1.02	1.16	1.30	1.45	1.55	1.73	1.94	2.11	2.39	2.65	2.89	3.31
15mm	1.25	1.50	1.59	1.77	1.89	2.12	2.39	2.58	2.92	3.24	3.55	4.06
20mm	1.45	1.64	1.84	2.05	2.19	2.45	2.76	2.98	3.38	3.74	4.09	4.69
30mm	1.77	2.01	2.26	2.51	2.68	3.00	3.38	3.65	4.13	4.58	5.01	5.74
40mm	2.05	2.32	2.61	2.89	3.09	3.46	3.89	4.22	4.77	5.29	5.79	6.63
60mm	2.50	2.84	3.19	3.54	3.79	4.24	4.77	5.17	5.58	6.48	7.09	8.12
80mm	2.89	3.29	3.69	4.09	4.38	4.89	5.11	5.97	6.75	7.48	8.19	9.93
100mm	3.24	3.67	4.12	4.58	4.89	5.48	6.16	6.67	7.54	8.37	9.17	10.48

Table Showing Single Offset For Copper Pipes (Without cold draw)

Expansion X	Pipe Nominal Bore											
	15nb	22nb	28nb	35nb	42nb	54nb	67nb	76nb	108nb	133nb	159nb	219nb
1mm	0.16	0.19	0.22	0.25	0.27	0.31	0.35	0.37	0.44	0.49	0.53	0.63
3mm	0.28	0.34	0.38	0.43	0.48	0.54	0.60	0.64	0.76	0.85	0.92	1.08
5mm	0.56	0.44	0.50	0.56	0.61	0.69	0.77	0.83	0.98	1.09	1.19	1.40
10mm	0.59	0.63	0.71	0.79	0.87	0.98	1.09	1.17	1.39	1.55	1.69	1.98
15mm	0.63	0.77	0.87	0.97	1.06	1.21	1.34	1.43	1.71	1.89	2.07	2.43
20mm	0.73	0.89	1.00	1.12	1.22	1.39	1.55	1.65	1.97	2.19	2.39	2.81
30mm	0.90	1.09	1.23	1.37	1.51	1.71	1.90	2.03	2.41	2.67	2.93	3.43
40mm	1.04	1.26	1.42	1.59	1.73	1.97	2.19	2.34	2.79	3.09	3.38	3.97
60mm	1.27	1.54	1.74	1.94	2.12	2.41	2.69	2.86	3.42	3.79	4.14	4.86
80mm	1.47	1.77	2.01	2.24	2.46	2.78	3.11	3.31	3.94	4.38	4.78	5.62
100mm	1.64	1.99	2.24	2.51	2.75	3.12	3.47	3.69	4.41	4.89	5.35	6.28

Cold draw can be used if the size of the loop cannot be accommodated. The rate of cold draw is normally 50% of the total movement. If the pipework is suspended using drop rods, it would be advisable to use DST Ball Hangers to reduce stresses as the pipework moves.



### Drop Rod Calculation Example:

Calculation of Drop Rod Length =  $\Delta \times \tan 5^\circ$

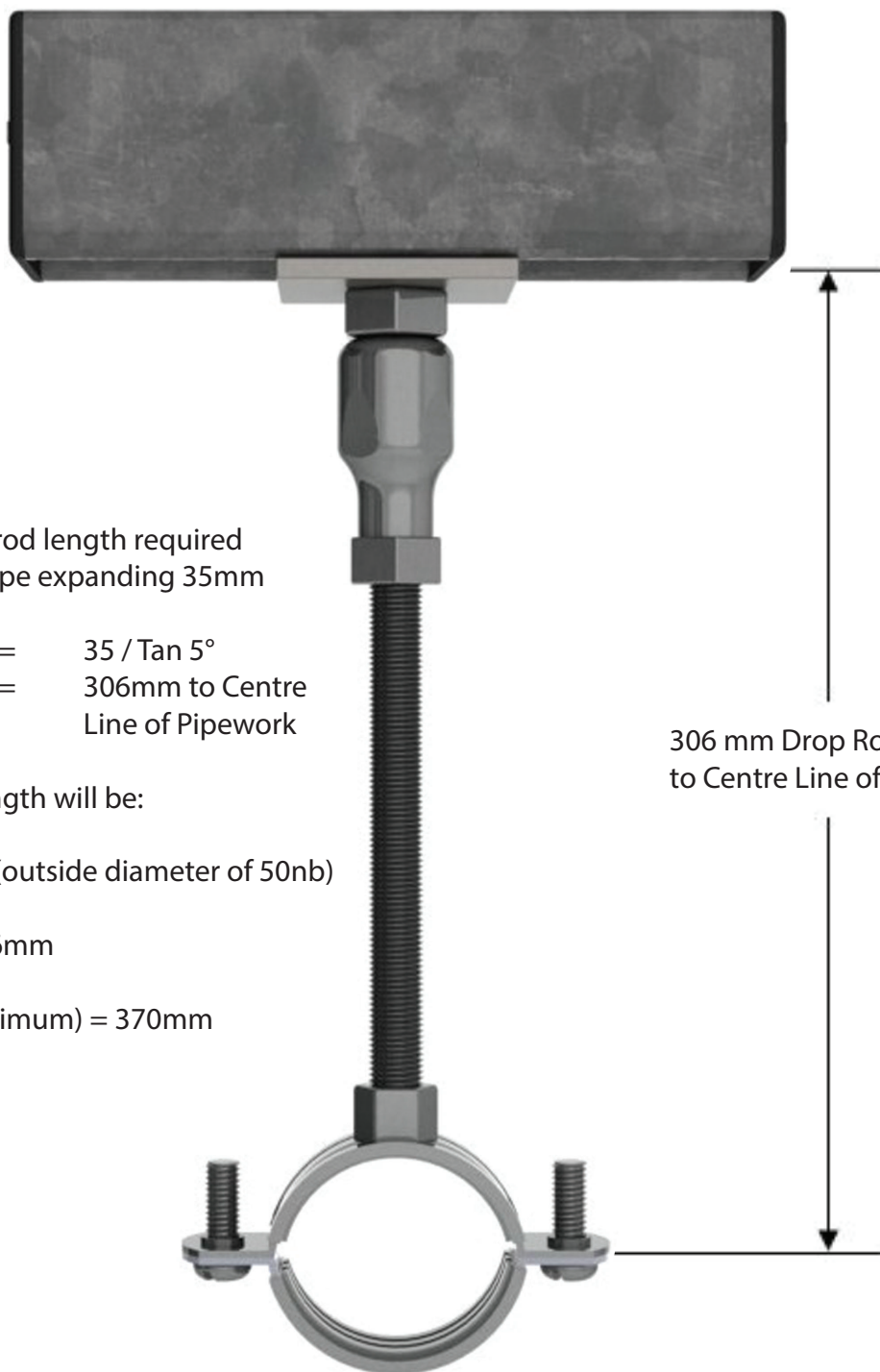

To Calculate the drop rod length required for a length of 50nb pipe expanding 35mm

$$\begin{aligned} \text{Expansion in mm} &= 35 / \tan 5^\circ \\ &= 306\text{mm to Centre Line of Pipework} \end{aligned}$$

Therefore drop rod length will be:

$$400\text{mm} - \frac{1}{2} \text{ of } 60\text{mm (outside diameter of 50nb)}$$

$$400\text{mm} - 30\text{mm} = 276\text{mm}$$

$$\text{Drop Rod Length (minimum)} = 370\text{mm}$$

306 mm Drop Rod Length to Centre Line of Pipework

If the drop rod length required is too long for the installation, DST Ball Hangers or DST Hemispherical Cups and Washers can be used to increase the movement, but decrease the drop rod length. Further advice can be given by one of our Technical Sales Engineers.

### ■ Pipe Anchors for AX1, AX2 and AX3 Expansion Compensators

Pipe anchors are needed to overcome the forces set up when axial bellows and under pressure. The following conditions can exist:

Pipeline under test pressure

Pipeline under working pressure and temperature

Each condition must be investigated:

- Pipeline under test pressure - this force is made up of test pressure multiplied by the effective area.
- Pipeline under working pressure and temperature - the force is made up of three components;
  - a. The force to overcome internal pressure; i.e working pressure multiplied by effective area.
  - b. The force to compress the expansion joint. This is calculated by using the force to compress in Newtons/mm.
  - c. The force to overcome the friction of pipe movement, which can be estimated at 30N per metre of pipeline for each 25mm of pipe diameter. This assumes about the worst possible condition of face to face sliding supports. Coefficient of friction about 0.4. If hangers or rollers are used, reduce the figure of 15N per metre of pipeline.

Thus the Total Force = a + b + c

Expansion joints should not be removed during a pressure test. The purpose of a pressure test is to put the pipeline under stresses greater than those which occur under working conditions. If the expansion joints are removed the anchors and guides are not subjected to any stresses and therefore faults in their design will not show up.

When positioning anchors, great care should be taken to ensure that the main structure to which the anchor is attached, is in fact strong enough to withstand the forces transmitted by the anchor. Also ensure that when a number of pipes are anchored at one point, the total force under working conditions is considered.

Bellow is an example showing the anchor forces set up under different conditions.

In these examples 1bar = 100kN/m<sup>2</sup>

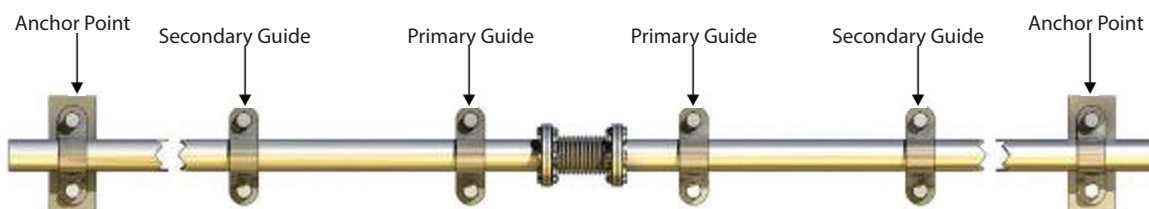

Calculate the anchor force for a 25m long pipeline of 32mm NB at 6 bar working pressure and temperature of 82°C, using modular slide guides.

At 82°C the expansion in mm/metre is 1.0

Therefore the total expansion is 1.0 x 25 = 25mm

Test pressure is 1.5 x working pressure = 1.5 x 6 = 9 bar (=900 kN/m<sup>2</sup>)

Effective area can be taken from the product catalogue, in this case = 16cm<sup>2</sup>

For a pipeline under the test conditions, TOTAL FORCE = test pressure x effective area = 900 x 16 x 0.1 = 1,440 N

Working Pressure of 6 (=600 kN/m<sup>2</sup>)

For a pipeline under working conditions, TOTAL FORCE = a + b + c

a = 600 x 16 x 0.1 = 960 N

b = 15 x 25 = 375N

c = 15 x 25 x  $\frac{32}{25}$  = 480 N

therefore, TOTAL FORCE = 960 + 375 + 480 = 1,815N

### Pipe Anchors Using Lateral/Angular Expansion Compensators FA1, FA2, AN1, AN2, GI1, GI2

It is preferable to install the above type of Expansion Compensators if the engineer has concerns over Anchor Loads. The Anchor Loads created by the use of these units are significantly lower than the load created by using an Axial Expansion Compensator.

Anchor Loads using Lateral / Angular Expansion Compensators are created from Two Fields.

1. The Force To Deflect The Expansion Compensator.
2. The Force Created Due to Frictional Resistance.

#### Example



1. The Force To Deflect. This information can be found earlier in this guide for DST Type DST/AN1/PN16. In this case 100mm it will be:  
$$\text{Force to Deflect Each Expansion Compensator} = 98 \text{ N / deg} \times 2$$
$$= 196.00 \text{ Newtons}$$
2. Force To Overcome Friction. In this example we will be bracketing using DST 114 Roller Chair and Guide, which has a frictional resistance of 30 Newtons.

$$\text{Force To Overcome Frictional Resistance} = 15 \times 90 \times \frac{100}{25} = 5400 \text{ Newtons}$$

Therefore The total Anchor Force Will Be:

$$1 = 196 \text{ Newtons} \quad + \quad 2 = 5400 \text{ Newtons}$$

$$\text{Anchor Load Total} = 5596 \text{ Newtons}$$

As you can see the majority of the Anchor Load is made up from the frictional resistance of pipework bracketry. It is advisable to use Pipework Bracketry which has a low frictional resistance such as a DST 253 Slide Guide. Please seek further advise from our technical sales team on frictional resistance and futher Pipework Bracketry.

These types of Expansion Compensators are can be used on a Drop Rod system.



DST 102 - Saddle Guide

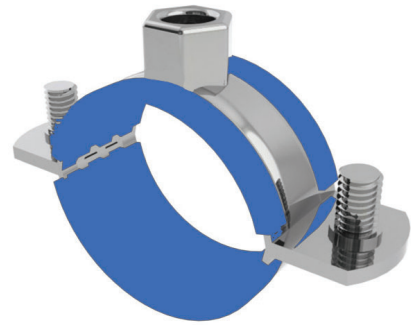

DS Guide CLips

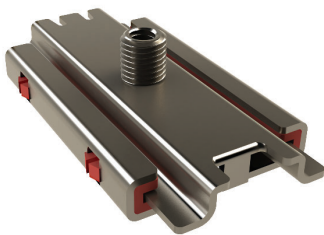

DST LF1, LF2 & LF3  
Low Friction Slide Guide



DST 132 - Nylon Coated Saddle  
Guide C/W Polypropolene Strip



DST240 (O) - Oversized Brass  
Munsen Ring

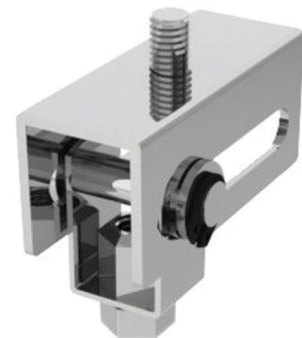

DST MS1 & MS2  
Modular Slide Guide

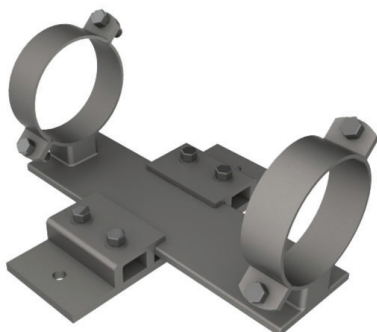

DST 253G - PTFE Slide Guide  
Bracket

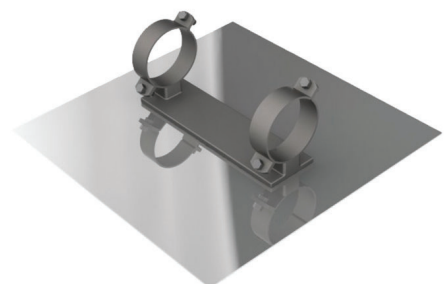

DST 253S - PTFE Skid Bracket

Nominal Size	Flange Table	Outer Ø	Nº of Bolt Holes	Bolt Hole Ø	Bolt Circle (P.C.D)	Nominal Size	Flange Table	Outer Ø	Nº of Bolt Holes	Bolt Hole Ø	Bolt Circle (P.C.D)	Key:
15mm 1/2"	E	95	4	14	67	80 mm 3"	E	184	4	18	146	E = BS10 Table 'E'
	F	95	4	14	67		F	203	8	18	165	F = BS10 Table 'F'
	H	114	4	18	83		H	203	8	18	165	H = BS10 Table 'H'
	150	89	4	16	60		150	191	4	19	152	150 = BS1560 Class 150, ASA 150, ANSI B16.5 Class 150
	300	95	4	16	67		300	210	8	22	168	300 = BS1560 Class 300, ASA 300, ANSI BS16.5 Class 300
	6	80	4	11	55		6	190	4	18	150	
	10	95	4	14	65		10	200	8	18	160	
	16	95	4	14	65		16	200	8	18	160	
20 mm 3/4"	25	95	4	14	65	25	200	8	18	160		
	E	101	4	14	73	E	216	8	18	178	6 = BS4504 PN6, DIN2501 PN6	
	F	101	4	14	73	F	229	8	18	191		
	H	114	4	18	83	H	229	8	18	191	10 = BS4504 PN10, DIN2501 PN16	
	150	98	4	16	70	150	229	8	19	191		
	300	117	4	19	83	300	254	8	22	200	16 = BS4504 PN16, DIN 2501 PN16	
	6	90	4	11	65	6	210	4	18	170		
	10	105	4	14	75	10	220	8	18	180		
25 mm 1"	16	105	4	14	75	16	220	8	18	180		
	25	105	4	14	75	25	235	8	22	190	25 = BS4504 PN25, DIN2501 PN25	
	E	115	4	14	83	E	254	8	18	210		
	F	121	4	18	87	F	279	8	22	235		
	H	121	4	18	87	H	279	8	22	235		
	150	108	4	16	79	150	254	8	22	216		
	300	124	4	19	89	300	279	8	22	235		
	6	100	4	11	75	6	240	8	18	200		
32 mm 1 1/4"	10	115	4	14	85	10	250	8	18	210		
	16	115	4	14	85	16	250	8	18	210		
	25	115	4	14	85	25	270	8	26	220		
	E	121	4	14	87	E	279	8	22	235		
	F	133	4	18	98	F	305	12	22	260		
	H	133	4	18	98	H	305	12	22	260		
	150	117	4	16	89	150	279	8	22	241		
	300	133	4	19	98	300	318	12	22	270		
40 mm 1 1/2"	6	120	4	14	90	6	265	8	18	225		
	10	140	4	18	100	10	285	8	22	240		
	16	140	4	18	100	16	285	8	22	240		
	25	140	4	18	100	25	300	8	26	250		
	E	121	4	14	98	E	337	8	22	292		
	F	133	4	18	105	F	368	12	22	324		
	H	133	4	18	105	H	368	12	22	324		
	150	117	4	16	98	150	343	8	22	298		
50 mm 2"	300	133	4	22	114	300	381	12	25	330		
	6	120	4	14	100	6	320	8	18	280		
	10	140	4	18	110	10	340	8	22	295		
	16	140	4	18	110	16	340	12	22	295		
	25	140	4	18	110	25	360	12	26	310		
	E	152	4	18	114	E	406	12	22	356		
	F	165	4	18	127	F	432	12	25	381		
	H	165	4	18	127	H	432	12	25	381		
65 mm 2 1/2"	150	152	4	19	121	150	406	12	25	362		
	300	165	8	19	127	300	444	12	29	387		
	6	140	4	14	110	6	375	12	18	335		
	10	165	4	18	125	10	395	12	22	350		
	16	165	4	18	125	16	405	12	26	355		
	25	165	4	18	125	25	425	12	30	370		
	E	165	4	18	127	E	457	12	25	406		
	F	184	8	18	146	F	489	16	25	438		
	H	184	8	18	146	H	489	16	25	438		
	150	178	4	19	140	150	482	12	25	432		
	300	191	8	22	149	300	521	16	32	451		
	6	160	4	14	130	6	440	12	22	395		
	10	185	4	18	145	10	445	12	22	400		
	16	185	4	18	145	16	460	12	26	410		
	25	185	8	18	145	25	485	16	30	430		



### Pressure Units

Symbol	Description	Bar	kPa	kN/m <sup>2</sup>	psi	atm	m wg
1 bar	Bar		100.0	100.0	14.5037	0.9869	10.1972
1 kPa	Kilopascal	0.01		1.0	0.145	0.0099	0.102
1 kN/m <sup>2</sup>	Kilonewton per square metre	0.01	1.0		0.145	0.0099	0.102
1 psi	Pound per square inch	0.0689	6.8948	6.8948		0.0681	0.07031
1 atm	Atmosphere	1.0133	101.3250	101.3250	14.696		10.3323
1 m wg	Metre water gauge	0.0981	9.8067	9.8067	1.422	0.0968	

### Vacuum Units

Symbol	Description	mm	Hg in Hg	psi	Torr	bar	atm
1mm Hg	Millimetre of mercury		0.0394	0.49	1.0	0.0013	0.0013
1 in Hg	Inch of mercury	25.4		0.019	25.4	0.00338	0.0334
1 psi	Pound per square inch	51.7	2.04		51.7	0.0689	0.0681
1 Torr	Torr	1.0	0.0394	0.49		0.0013	0.0013
1 bar	Bar	750	29.53	14.5037	750		0.9869
1 atm	Atmosphere	760	29.92	14.696	760	1.0133	

### Linear Units

Symbol	Description	mm	cm	m	in	ft	yd
1 mm	Millimetre		0.1	0.001	0.0394	0.0033	0.0011
1 cm	Centimetre	10		0.1	0.3937	0.0328	0.0109
1 m	Metre	1000	100		39.3701	3.2808	1.0936
1 in	Inch	25.4	2.54	0.0254		0.0833	0.0278
1 ft	Foot	304.8	30.48	0.3048	12		0.3333
1 yd	Yard	914.4	91.44	0.9144	36	3	

### Weight Units

Symbol	Description	g	kg	t	oz	lb	tn
1 g	Gramme		0.001	0.000001	0.036	0.0022	0.0000098
1 kg	Kilogramme	1000		0.001	36.413	2.2047	0.0009843
1 t	Tonne (metric)	1000000	1000		36413.44	2204.7222	0.984251
1 oz	Ounce	28.4	0.0284	0.0000284		0.0625	0.0000279
1 lb	Pound	453.6	0.4536	0.0004536	16		10.0004465
1 tn	Ton (imperial)	1016000	1016	1.016	35840	2240	

### Temperature Units

Symbol	Description	°C	°F	°K
°C	Degree Celsius		Times 1.8, plus 32	Plus 273.16
°F	Degree Fahrenheit	Minus 32 divide 1.8		Divide 1.8 plus 255.38
°K	Degree Kelvin	Minus 273.16	Minus 255.38	

Nominal Size	Material	Wall Thickness	Max O/D	Min O/D	Mean I/D	Int Cross Section Area	Metal Cross Section Area	Surface Area	Moment of Inertia	Section Modulus	Pipe Weight	Water Content
		mm	mm	mm	mm	mm <sup>2</sup>	mm <sup>2</sup>	m <sup>2</sup>	cm <sup>4</sup>	cm <sup>3</sup>	kg/m	l/m
15 mm	Heavy Steel	3.25	21.7	21.1	14.9	175	186	0.067	0.79	0.736	1.45	0.175
	Medium Steel	2.65	31.7	21.1	16.2	205	155	0.067	0.71	0.656	1.22	0.250
1/2"	Copper (Table X)	0.70	15.045	14.965	13.6	145	31.6	0.047	0.08	0.108	0.28	0.145
	Copper (Table Y)	1.00	15.045	14.965	13.0	133	44.1	0.047	0.11	0.145	0.39	0.133
15 mm	Copper (Table Z)	0.50	15.045	14.965	14.0	154	22.9	0.047	0.06	0.080	0.20	0.154
20 mm	Heavy Steel	3.25	27.2	26.6	20.4	326	243	0.085	1.75	1.29	1.90	0.326
	Medium Steel	2.65	27.2	26.6	21.6	367	203	0.085	1.50	1.11	1.58	0.367
3/4"	Copper (Table X)	0.90	22.055	21.975	20.2	321	59.6	0.069	0.33	0.303	0.52	0.321
	Copper (Table Y)	1.20	22.055	21.975	19.6	302	78.3	0.069	0.43	0.387	0.69	0.302
22 mm	Copper (Table Z)	0.60	22.055	21.975	20.8	340	40.2	0.069	0.23	0.210	0.35	0.340
25mm	Heavy Steel	4.05	34.2	33.4	25.7	518	380	0.106	4.29	2.54	2.97	0.518
	Medium Steel	3.25	34.2	33.4	27.3	586	312	0.106	3.70	2.20	2.44	0.586
1"	Copper (Table X)	0.90	28.055	27.975	26.2	540	76.7	0.085	0.71	0.504	0.68	0.540
	Copper (Table Y)	1.20	28.055	27.975	25.6	516	101	0.085	0.91	0.650	0.89	0.516
28 mm	Copper (Table Z)	0.60	28.055	27.975	26.83	565	51.7	0.085	0.49	0.347	0.46	0.565
32 mm	Heavy Steel	4.05	42.9	42.1	34.3	927	490	0.134	9.16	4.31	3.84	0.926
	Medium Steel	3.25	42.9	42.1	35.9	1016	461	0.134	7.74	3.64	3.14	1.016
1 1/4"	Copper (Table X)	0.90	35.07	34.99	32.6	837	128	0.110	1.83	1.043	1.12	0.837
	Copper (Table Y)	1.20	35.07	34.99	32.0	806	158	0.110	2.22	1.270	1.39	0.806
35 mm	Copper (Table Z)	0.70	35.07	34.99	33.6	889	75.5	0.110	1.11	0.635	0.67	0.889
40 mm	Heavy Steel	4.05	48.8	48.0	40.2	1272	566	0.152	13.98	5.79	4.43	1.271
	Medium Steel	3.25	48.8	48.0	41.9	1376	461	0.152	11.78	4.87	3.61	1.376
1 1/2"	Copper (Table X)	1.20	42.07	41.99	39.6	1234	154	0.132	3.21	1.528	1.36	1.234
	Copper (Table Y)	1.50	42.07	41.99	39.0	1197	191	0.132	3.93	1.869	1.69	1.197
42 mm	Copper (Table Z)	0.80	42.07	41.99	40.4	1284	104	0.132	2.20	1.048	0.91	1.284
50 mm	Heavy Steel	4.50	60.8	59.8	51.3	2070	784	0.189	30.8	10.2	6.17	2.070
	Medium Steel	3.65	60.8	59.8	53.0	2205	651	0.189	26.2	8.7	5.10	2.205
2"	Copper (Table X)	1.20	54.07	53.99	51.6	2095	199	0.170	7.0	2.573	1.76	2.095
	Copper (Table Y)	2.00	54.07	53.99	50.0	1965	327	0.170	11.1	4.101	2.88	1.965
54 mm	Copper (Table Z)	0.90	54.07	53.99	52.2	2145	150	0.170	5.3	1.963	1.33	2.145
65 mm	Heavy Steel	4.50	76.6	75.4	67.00	3530	1005	0.239	64.5	170	7.90	3.530
	Medium Steel	3.65	76.6	75.4	68.7	3700	831	0.239	54.5	14.3	6.51	3.700
2 1/2"	Copper (Table X)	1.20	66.75	66.60	64.3	3245	247	0.209	13.2	3.97	2.18	3.245
	Copper (Table Y)	2.00	66.75	66.60	63.1	3125	406	0.209	21.3	6.38	3.58	3.125
67 mm	Copper (Table Z)	1.00	66.75	66.60	64.7	3285	206	0.209	11.1	3.34	1.82	3.285
80 mm	Heavy Steel	4.85	89.5	88.1	79.0	4905	1285	0.279	114	25.6	10.1	4.905
	Medium Steel	4.05	89.5	88.1	80.7	5115	1080	0.279	97.0	21.8	8.47	5.115
3"	Copper (Table X)	1.50	76.3	76.15	73.2	4210	352	0.239	24.4	6.45	3.11	4.210
	Copper (Table Y)	2.00	76.3	76.15	72.2	4100	467	0.239	31.9	8.43	4.11	4.100
76 mm	Copper (Table Z)	1.20	76.3	76.15	73.8	4280	283	0.239	19.9	5.22	2.50	4.280
100 mm	Heavy Steel	5.40	114.9	113.3	103.3	8380	1840	0.358	272	47.7	14.4	8.380
	Medium Steel	4.50	114.9	113.3	105.1	8680	1540	0.358	231	40.6	12.1	8.680
4"	Copper (Table X)	1.50	108.25	108.0	105.1	8680	504	0.340	71.4	13.21	4.45	8.680
	Copper (Table Y)	2.00	108.25	108.0	103.1	8355	832	0.340	115	21.41	7.33	8.355
108 mm	Copper (Table Z)	1.20	108.25	108.0	105.7	8780	405	0.340	71.2	10.66	3.57	8.780
125 mm	Heavy Steel	5.40	140.6	138.7	127.7	13050	2270	0.438	520	73.4	17.8	13.05
	Medium Steel	4.85	140.6	138.7	129.8	13250	2065	0.438	470	67.4	16.2	13.25
5"	Copper (Table X)	1.50	133.5	133.25	130.4	13350	621	0.419	134	20.26	5.47	13.35
	Copper (Table Y)	1.50	133.5	133.25	130.4	13350	621	0.419	134	20.26	5.47	13.35
133 mm	Copper (Table Z)	1.50	133.5	133.25	130.4	13350	621	0.419	134	20.26	5.47	13.35
150 mm	Heavy Steel	5.40	166.1	164.1	154.3	18700	2700	0.518	862	105	21.2	18.70
	Medium Steel	4.85	166.1	164.1	155.3	18950	2065	0.518	787	95.4	19.2	18.95
6"	Copper (Table X)	2.00	159.5	159.25	155.4	18950	988	0.501	304	38.42	8.71	18.95
	Copper (Table Y)	1.50	159.5	159.25	156.4	19200	743	0.501	203	29.09	6.55	19.20
159 mm	Copper (Table Z)	1.50	159.5	159.25	156.4	19200	743	0.501	203	29.09	6.55	19.20
200 mm	Steel	4.88			209.3	34400	3280	0.689	1880	172	25.9	34.42
250 mm	Steel	6.35			260.4	53250	5320	0.859	4745	347	42.0	53.24
300 mm	Steel	7.14			309.6	75300	7080	1.018	8865	547	55.8	75.30

Support Spacing - Space Supports as Table						
Pipe Bore (mm) Nominal	Maximum Support Spacing (m)					
	Steel Pipe		Copper Pipe		Iron Pipe	
	Horizontal	Vertical	Horizontal	Vertical	Horizontal	Vertical
Up to 15	1.8	2.4	1.2	1.8	-	-
20	2.4	3.0	1.4	2.1	-	-
25	2.4	3.0	1.8	2.4	-	-
32	2.7	3.0	2.4	3.0	-	-
40	3.0	3.6	2.4	3.0	-	-
50	3.0	3.6	2.7	3.0	1.8	1.8
65	3.7	4.6	3.0	3.6	-	-
80	3.7	4.6	3.0	3.6	2.7	2.7
100	3.7	4.6	3.0	3.6	2.7	2.7
125	3.7	5.4	3.0	3.6	-	-
150	4.5	5.4	3.6	4.2	3.7	3.7
200	5.0	6.0	-	-	3.7	3.7
250	5.0	6.0	-	-	4.5	5.4
300	6.1	10.0	-	-	8.0	10.0
350	10.0	12.0	-	-	-	-
400	10.5	12.6	-	-	-	-
450	11.0	13.2	-	-	-	-
500	12.0	14.4	-	-	-	-
600	14.0	16.8	-	-	-	-

Pipe Bore (mm) Nominal	Maximum Support Spacing (m)					
	UPVC Pipe		PE Pipe		Glass Pipe	
	Class O,B,C Horizontal	Class D,E,6,7 Vertical	Type 32 Horizontal	Type 50 Vertical	Horizontal	Vertical
Up to 10	-	0.6	0.3	0.45	-	-
15	-	0.6	0.4	0.6	-	-
20	-	0.65	0.4	0.6	-	-
25	-	0.75	0.4	0.6	-	-
32	-	0.8	0.45	0.7	-	-
40	-	0.9	0.45	0.7	0.9	1.7
50	1.1	1.2	0.55	0.85	1.2	1.7
65	1.2	1.4	0.55	0.85	-	-
80	1.4	1.5	0.6	0.9	1.2	1.7
100	1.5	1.7	0.7	1.1	1.2	1.7
125	1.7	1.9	-	-	-	-
150	1.8	2.1	-	1.3	1.2	1.7
175	2.0	2.3	-	-	-	-
200	2.1	2.5	-	-	-	-
225	2.3	2.7	-	-	-	-
250	2.4	2.9	-	-	-	-
300	2.6	3.1	-	-	-	-
350	2.9	3.4	-	-	-	-
400	3.1	3.7	-	-	-	-
450	3.4	3.7	-	-	-	-

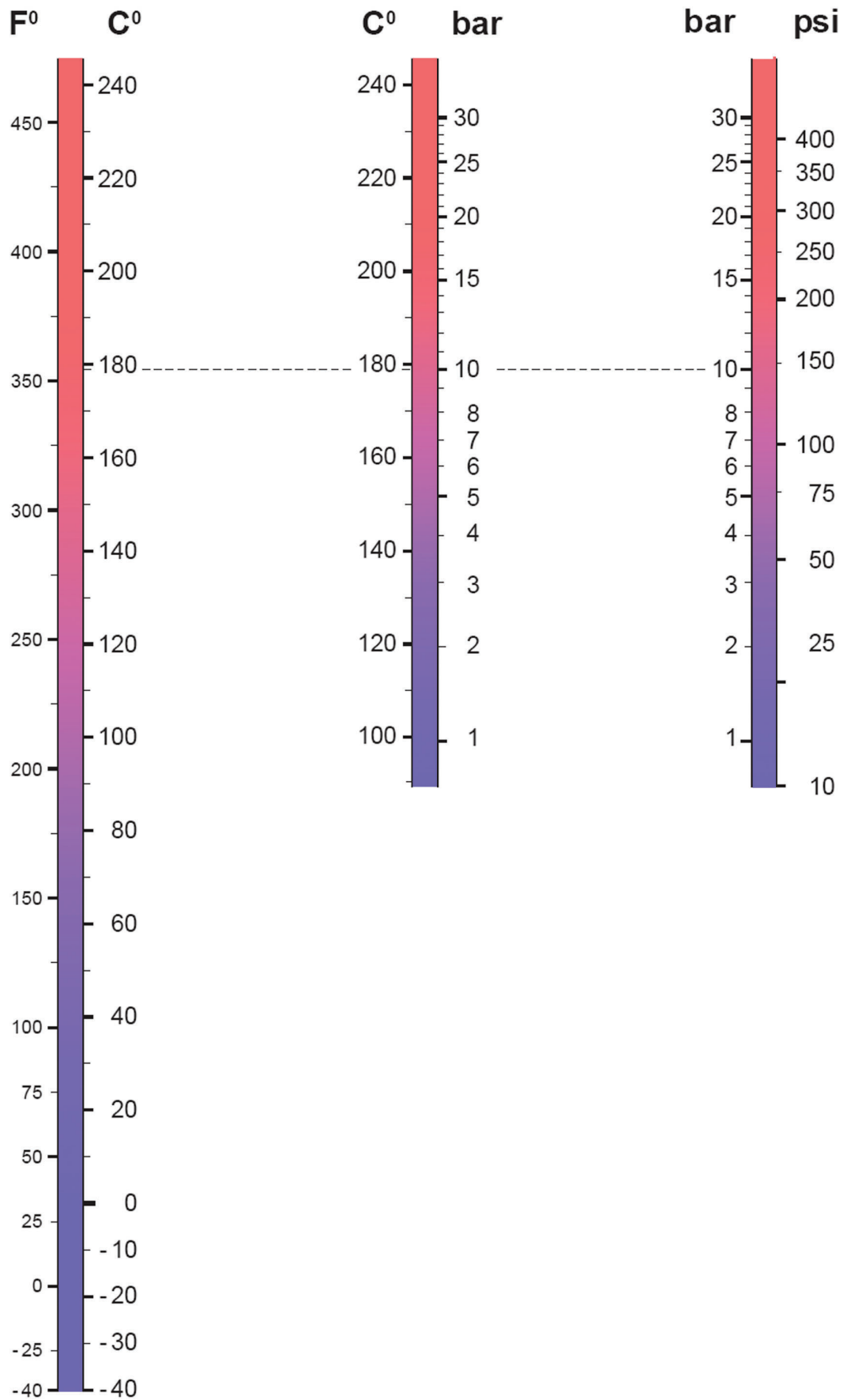

## Flow Conversion Table

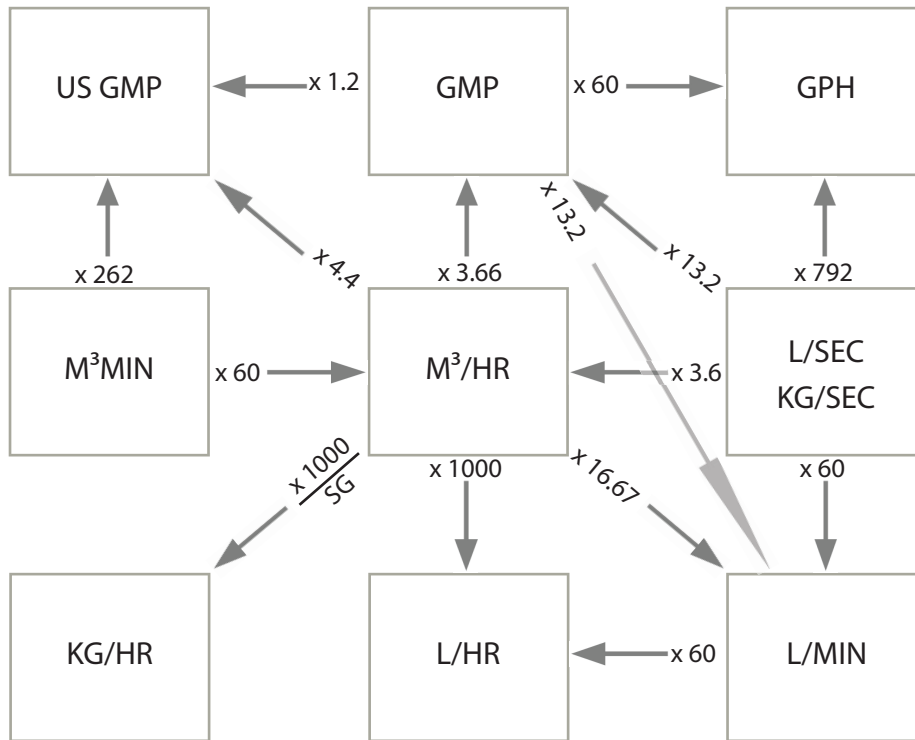

Multiply by conversion factor in direction of arrow.  
Divide by conversion factor for opposite requirement, eg.  $GPM \div 13.2 = L/SEC$

## Pressure Conversion Table

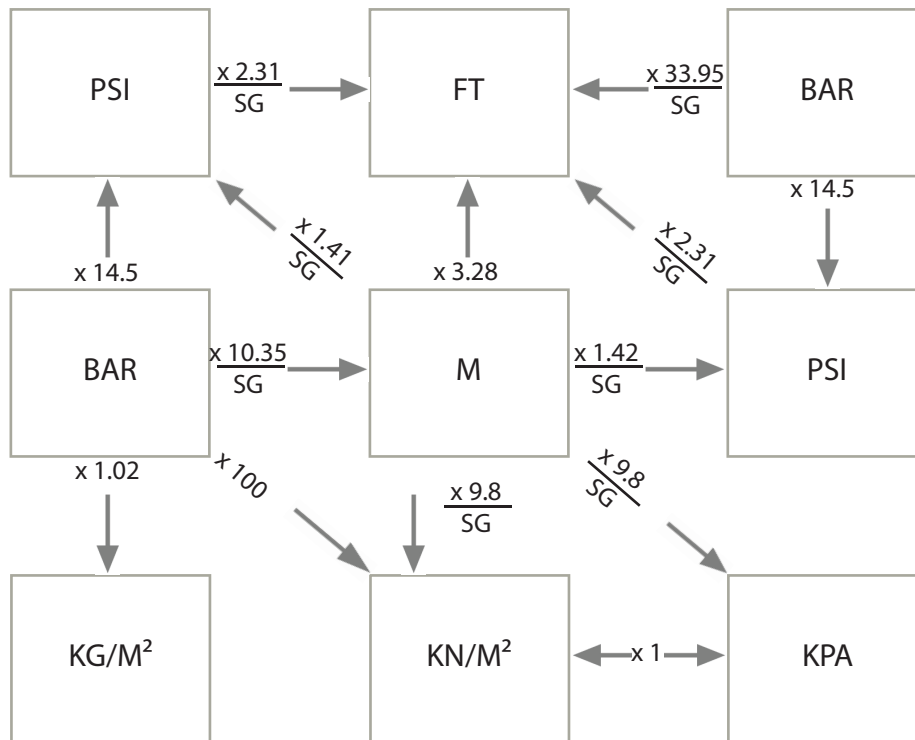

Multiply by conversion factor in direction of arrow.  
Divide by conversion factor for opposite requirement, eg.  $PSI \div 1.42 = M$



# DST Group Limited June 2016 STANDARD CONDITIONS OF SALE

## 1) Interpretation

In these conditions the following terms have the following meaning:-

**Seller** - DST Group Limited

**Buyer** - The person, firm or company purchasing the products subject of the contract between the Seller and the Buyer

**Products** - The goods or materials which shall be the subject of the contract between the Seller and the Buyer

**Price** - The price specified in the Seller's quotation, acknowledgement, order or otherwise communicated to the Buyer and agreed

## 2) General

2.1. These conditions prevail over any conditions stipulated by the Buyer, whether express or by implication or incorporation. If the Buyer's documentation shall contain any conditions as to sale and purchase they shall be of no contractual effect between the Seller and the Buyer.

2.2. Save as is otherwise expressly agreed in writing by the Seller or as is expressly provided in these conditions all guarantees, warranties, conditions, representations or stipulations whether expressed or implied and whether arising hereunder or under any prior agreement or statement, or by statute, common law or otherwise are hereby excluded and negated, provided that nothing in this clause or elsewhere in these conditions shall operate to exclude the provisions of Section 12 of the Sales of Goods Act 1979 and the Consumer Rights Act 2015 or to exclude or restrict liability for death or personal injury resulting from the Seller's negligence.

2.3. In the event that the Buyer produces to the Seller at any stage conditions upon which the Buyer will enter any agreement to acquire the Products the terms of these Standard Conditions of Sale shall prevail over the Buyer's conditions in the event of conflict.

## 3) Orders

3.1. Orders for products shall be in writing and are accepted by the Seller subject to these conditions unless otherwise varied in writing.

3.2. Once an order has been placed by the Buyer it may not be suspended, cancelled or amended without the Seller's prior written agreement. The Buyer shall be responsible for the cost of all purchases, stocks, work-in-progress, labour costs, unrecovered overheads, and other expenses suffered by the Seller as a result of such suspension, cancellation or amendment.

3.3. Products are supplied specifically for the purposes mentioned in the Order/Order Acknowledgement and for no other purposes.

## 4) The Price

4.1. All prices given, published or put forward are quotations unless otherwise expressly stated therein. Prices quoted are prices prevailing at the date of quotation and are subject to increase. The Seller may at any time before delivery increase the price of the undelivered products or balance of the products by notice in writing to the Buyer. Prices invoiced are prices prevailing at the date of despatch.

4.2. Unless otherwise stated on acceptance, the price of the products shall include the Seller's costs of standard packing, normal insurance and delivery of the products to any one address in the United Kingdom maintained specified in writing by the Buyer and agreed by the Seller prior to delivery.

## 5) Payment

5.1. Unless otherwise stated on the Seller's invoice or otherwise agreed in writing, payment for the products shall be made not later than thirty days after the end of the month of invoicing but so that the Seller may at any time on or after acceptance by notice in writing to the Buyer vary the terms of payment by demanding immediate payment or (at the Seller's option) adequate security for sums which will be due hereunder.

5.2. Time of payment shall be of the essence and failure by the Buyer to pay the price or any installment thereof in due time shall entitle the Seller to treat such failure as a repudiation of the whole contract by the Buyer and to require the Buyer to make immediate payment of all monies due or become due and to recover from the Buyer damages for such breach of contract and/or (at the Seller's option) to charge interest at four per cent per annum above the base rate of Barclays Bank PLC from due date until payment.

## 6) Delivery

Unless otherwise agreed in writing between the Seller and the Buyer the following provisions shall apply:-

6.1. Delivery of the products shall have taken place when the products have been delivered to the address specified on the Seller's quotation, acknowledgement or other document or if the Buyer refuses to accept delivery, at the time when the products are due and ready for delivery in such latter instance the Seller shall be entitled to arrange storage for the products and to charge such storage and other costs to the Buyer and

the Buyer shall also be responsible for the payment of interest on any unpaid sum in accordance with clause 5.2.

6.2. The delivery date or dates specified on the Seller's acceptance of order are estimates only. The Seller shall not be liable for failure to deliver by such date or dates or for any damage or loss arising directly or indirectly out of delay in delivery; nor shall the Buyer be entitled to refuse to accept the Products because of late delivery.

6.3. Where delivery is to be made by installments, each delivery shall be deemed for such purpose to be the subject of a separate contract and any failure whatsoever by the Seller in respect of any one delivery shall not entitle the Buyer to repudiate the contract or any installments remaining to be delivered thereunder.

6.4. The risk of any loss or damage to or deterioration of the products shall be borne by the Buyer from the time delivery has taken place in accordance with clause 6.1.

6.5. In respect of sea transit the Seller shall not be required to give the Buyer the notice relating to insurance of the products referred to in Section 32(3) of the Sales of Goods Act 1979 and the Consumer Rights Act 2015.

6.6. The Buyer is deemed to have accepted the Products after a period of 3 days after the date of delivery.

6.7. The Buyer shall make all necessary arrangements to take delivery of the Product on the date when the Products are tendered for delivery.

## 7) Property

Notwithstanding delivery and the passing of risk:-

7.1. The property in the products shall remain the Seller's until payment in full has been made to the Seller by the Buyer for the products and all other sums due to the Seller at the date of delivery of the products.

7.2. Where full payment has not been made to the Seller and the Buyer uses the products in his manufacturing process or incorporates the products with other products the property in the products shall be retained by the Seller insofar as such products are identifiable and insofar as they are incorporated with other products the Seller's title in the products shall transfer into the product of which the products form a part. The Seller also reserves the right to trace into the proceeds of sale of the products or of the products of which the products form a part to the extent that the Seller remains unpaid.

7.3. Until such payment is made the Buyer shall hold all products and materials the property in which is vested in the Seller on a fiduciary basis only and in any of the events specified above the Buyer shall store such products and materials so as to be marked and clearly identifiable as the property of the Seller in any dispute relating thereto.

7.4. The Buyer grants the Seller the right of entry (by force, if necessary) upon the Buyer's premises to recover the products if the Buyer is in breach.

## 8) Lien

The Seller shall in respect of all unpaid debts due from the Buyer under the same or any other contract have a general lien on all products and property of the Buyer in his possession (although the products or some of them may have been paid for) and shall after the expiration of fourteen days written notice to the Buyer be entitled to dispose of such products and property as it deems fit, and apply the proceeds towards such debts.

## 9) Loss/Damage/Storage

9.1. Unless otherwise agreed in writing between the Buyer and Seller the Seller may deliver against any order an excess and/or deficiency up to ten per cent of weight or volume ordered without any liability whatsoever to the Buyer save that the price shall be adjusted accordingly.

9.2. The Buyer shall inspect the products immediately upon delivery and shall within 3 days of such delivery (time being of the essence) give notice in writing to the Seller and the carrier of all claims on account of damage to or total or partial loss of Products in transit. Claims for non-delivery must be submitted in writing to the Seller within fourteen days after notification of despatch. Quality claims must be made in writing immediately after the Buyer learns of the defect and in any event not later than thirty days after the Buyer's receipt of the products. Any claim not made in writing and received by the Seller within the aforesaid time limits shall be deemed waived.

9.3. If the Buyer establishes to the satisfaction of the Seller that products have been damaged in transit or that the consignment is incomplete, the Seller will, at the Seller's option, repair or replace such products or credit the Buyer with the value thereof as appropriate, provided that the Buyer shall have given to the Seller written notification (otherwise than upon the carrier's delivery document) of such damage or shortage as provided in clause 9.2. The Seller shall be permitted a reasonable opportunity to inspect any damaged consignment and to investigate any shortage.

9.4. Save as provided in clause 9.3 above, the Seller shall not be liable to the Buyer for any loss or damage arising out of or in connection with products damaged or shortages.

9.5. If the Seller fails to make delivery or makes defective delivery of any one installment such failure or defective delivery shall not vitiate the contract as regards other installments.

9.6. The right of the Buyer to set off the value of any shortage, defective products or products not otherwise conforming to contract shall be restricted to the specific invoice for the products in question and shall not apply to previous or future accounts.

## 10) Liability/Limitation and Warranty

10.1. All conditions, guarantees, or warranties express or implied by statute, common law or otherwise including (but without prejudice to the generality of the foregoing) conditions, guarantees or warranties as to quality, fitness for purpose or description of the products or their life or wear or use under any conditions whether known or made known to the Seller or not are hereby excluded.

10.2. The Seller's liability for any and all direct loss or damage resulting to the Buyer from defects in the products or any other cause shall be limited to the purchase price of the quantity of the products in respect of or in relation to which such loss or damage is claimed. The Seller shall not be liable for any loss, damage or expense caused to the Buyer by reason of any labour costs or other expenditure incurred by the Buyer or for any indirect or consequential loss or damage howsoever arising. Subject as aforesaid the Seller shall be under no liability in contract or in tort for any loss or damage or personal injury arising directly or indirectly out of the supply or use of the products or containers other than death or personal injury resulting from the negligence of the Seller within the meaning of Section 1 of the Unfair Contract Terms Act 1977 and the Consumer Rights Act 2015.

## 11) Force Majeure

11.1. Deliveries may be partially or totally suspended by either party during any period in which it is prevented from manufacturing, delivering or taking delivery of the products through any circumstances outside its control. If because of such circumstances, the Seller is unable to supply the total requirement of the products the Seller may allocate its available supply (after satisfaction of its own requirements) amongst all of its customers, including those not under contract, as the Seller thinks fit. Deliveries so suspended shall be cancelled without liability, but the contract between the parties shall otherwise remain unaffected.

11.2. For the purpose of these conditions, circumstances outside the Seller's control include acts of God, strikes, lock-outs, other industrial action, fire, accident, lightning, earthquakes, storms, floods, explosion, war, governmental restriction and any other circumstances, whether similar or dissimilar, beyond the reasonable control of the Seller.

## 12) Indemnity

The Buyer shall indemnify the Seller in respect of all damage or injury occurring to any person, firm, company or property and against all actions, suits, claims and demands, charges or expenses in connection therewith for which the Seller may become liable in respect of the products sold under the contract in the event that the damage or injury shall have been occasioned otherwise than by the negligence of the Seller.

## 13) Default

The Seller reserves the right (without prejudice to its other rights and remedies) either to terminate the contract between the parties or to suspend further deliveries under it or require payment in advance in the event that the Buyer fails to pay for any one delivery when the same becomes due or the Buyer's financial responsibility becomes unsatisfactory to the Seller or if the Buyer, being a company, goes into liquidation or has a receiver appointed or not being a company has a receiving order made against him or enters into any arrangement or composition with creditors.

## 14) V.A.T.

All prices quoted are exclusive of all import duties, V.A.T. and other imposts which will be for the Buyer's account and should be added to the price as appropriate.

## 15) Intellectual Property

No representation, warranty or indemnity is given by the Seller that the products do not infringe any letters patent, trademarks, registered designs or other industrial rights.

## 16) Product Liability

16.1. The Buyer shall ensure that the products are transported, stored, fitted and used in accordance with any specifications or instructions which the Seller may provide.

16.2. The Buyer shall ensure that customers of the products incorporating the products shall be warned of the nature of the products and shall be given any information in respect of any claims made against the Seller where the Buyer has failed to comply with clause 16.1 above.

## 17) Assignability

The contract of which these conditions form part is personal to the Buyer and the benefit thereof shall not be assigned without the Seller's written consent.

## 18) Proper Law

These conditions and the contract between the parties shall be construed and applied in accordance with the Law of England and the English Courts shall have sole jurisdiction in any dispute relating thereto.



Certificate Number **4185**  
**ISO 9001 14001 45001**

