

DST GROUP

DST Group Ltd

Product Brochure 2022



Tel:01524 389 494

www.dstgroup.co.uk sales@dstgroup.co.uk

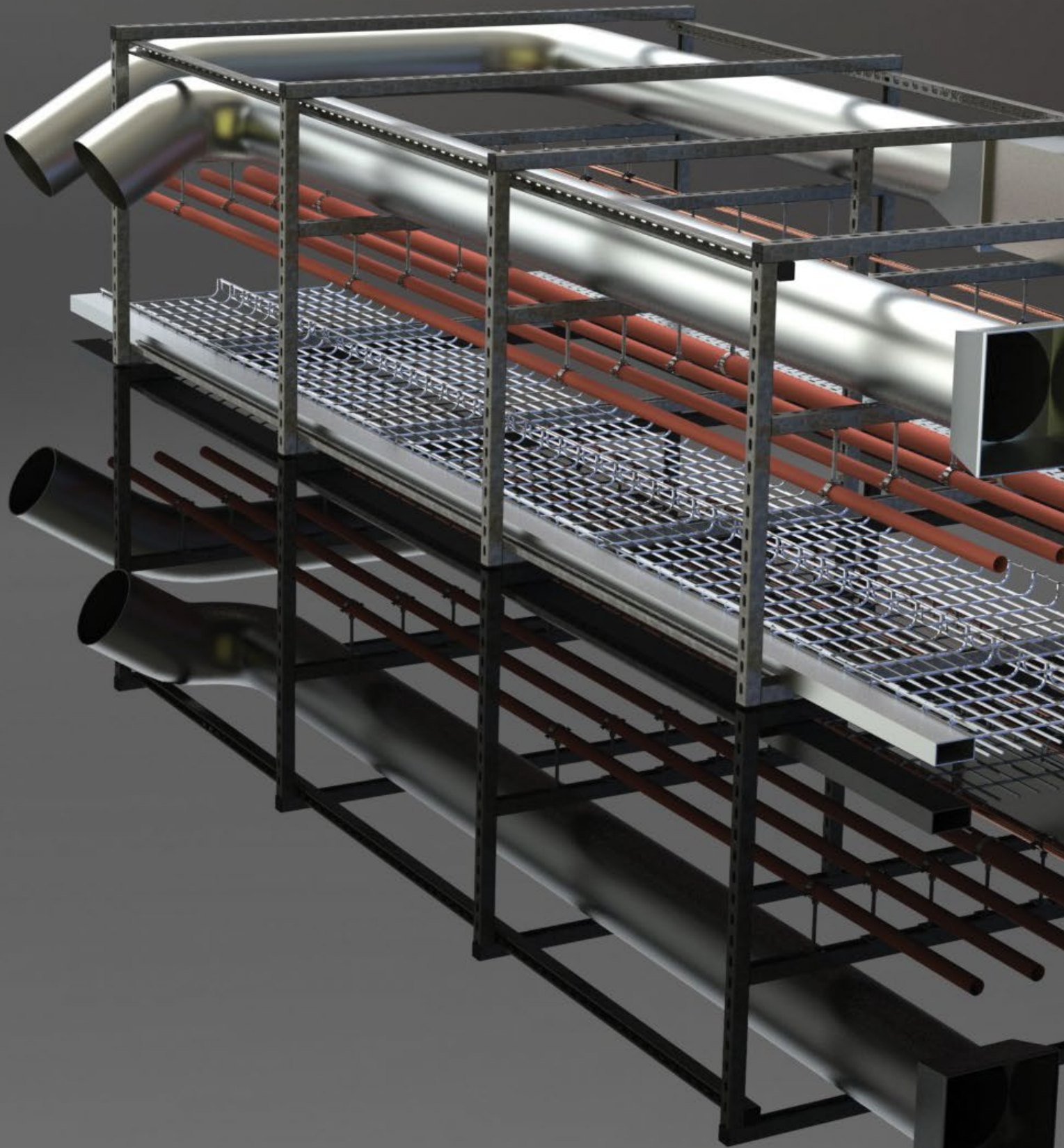



Since its opening in 1993 DST Group Ltd has been committed to providing quality products and services, professional technical support and the highest level of customer service.

DST Group Ltd is one of the leading manufacturers and distributors of engineering equipment in the UK today.

Our diverse range of products include:

1. Brackets & Pipe Support Systems
2. Expansion & Anti-vibration Equipment
3. Air & Dirt Removal Equipment

Based upon a firm technical background, our engineers can help, advise and design solutions to many aspects of site installation. We can offer stress analysis pipework systems.

In September 2004 we moved to our new 19,000 square foot warehouse and distribution centre in Morecambe, housing in excess of 1500 tonnes of stock. From this location we can supply equipment from stock on a next day service anywhere within mainland UK.

In May 2004, DST Group Ltd attained ISO 9001: 2000 Quality Management System and in February 2011, this was extended to include ISO 14001 and ISO45001 thus offering a totally integrated management system including Environmental Control and Health and Safety.

In addition we have a purpose built sales office which was completed in 2022, which we believe will help us exceed customer service levels beyond our current levels.



Mechanical Equipment.....7



Expansion & Anti Vibration.....31



ExpansionGuide.....63

Pipe Support Systems



- 7 Surefix XL Unlined Clip
- 8 Surefix XL Rubber Lined Clip
- 9 Heavy Duty Surefix HD Unlined & Lined Clip
- 10 DST100 - Split Band
- 11 Split Band Accessories
- 12 DST105 - Bossed Split Band
- 13 DST 102/103 - Saddle
- 14 DST132/133 - Saddle
DST170 - LPCB Approved Filbow Clamp
- 15 Phenolic Pipe Support
- 16 Hardwood Pipe Support
Calcium Silicate Insulation
- 17 DST 104 Standard & Extended 'U' Bolt
- 18 Guide Clips
DST MS1 & 2 Modular Slide Guide Assembly
DSTBH - Ball Hanger
- 19 DST LF Low Friction Slide Guides
- 20 DSTAAB - Adjustable Anchor Bracket
- 21 DST Slip & Band Anchors
- 22 DST114 Roller & Chair Guide Assembly
DST115 Hanger Roller
- 23 DST118 Roller Chair
DST134 S/E 'U' Bolt
- 24 DST240 G/M/B - Munsen Rings
DST241 G/M/B - School Board Clips
DST242 G/M/B - Backplates
- 25 Fixings
- 26 DST Strut Systems
Cantilever Arms
Square Plate Washers
Channel Nuts
- 26-27 DST Strut Brackets
- 28 Threaded Rod

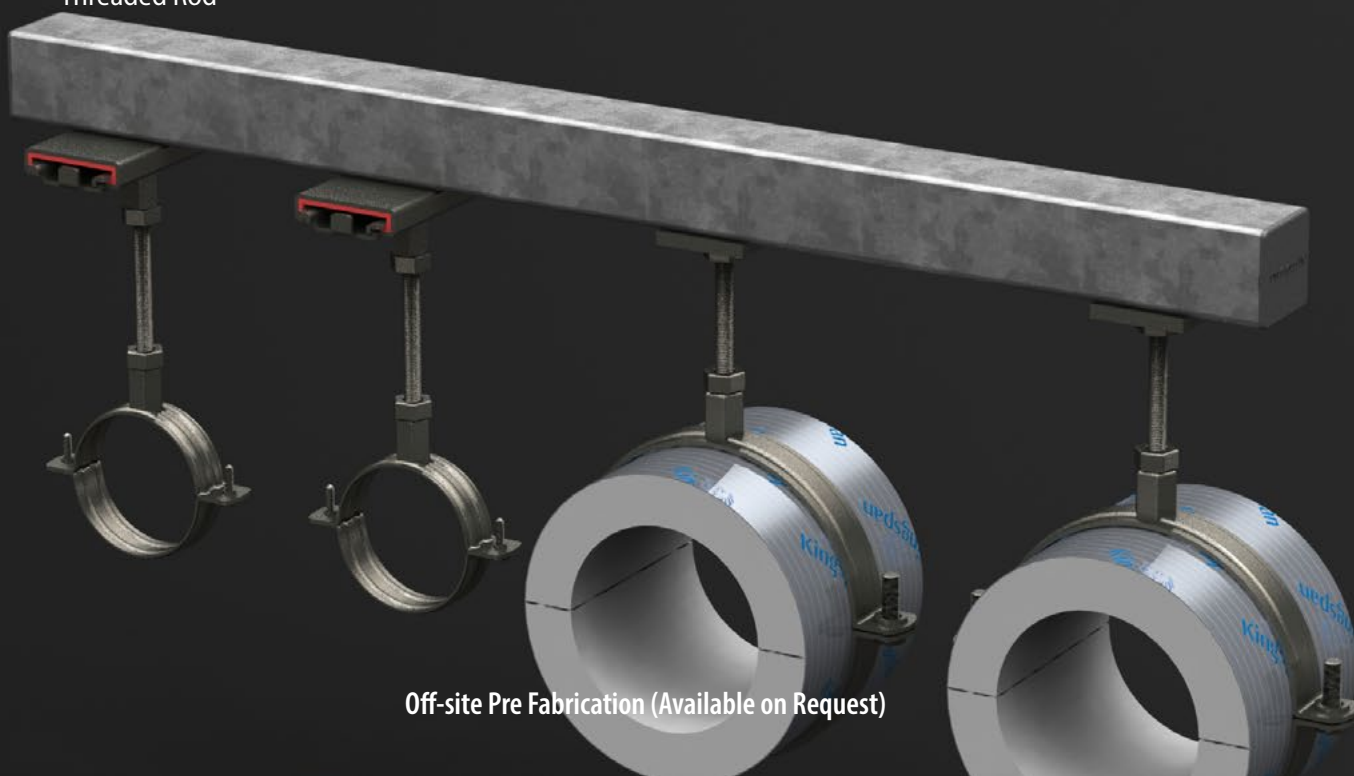

Off-site Pre Fabrication (Available on Request)

Construction

Mild Steel
 BZP Finish

For Use With

Steel & Cast Iron Tubes
 Insulated Pipe Supports



Pipe Size	Grip Range (mm)	Boss Type	Screw (mm)	Material (mm)
1/2"	19-23	M8/M10	M5 x 25	1 x 20
22mm	23-28	M8/M10	M5 x 25	1 x 20
3/4"	26-25	M8/M10	M5 x 25	1 x 20
1"	32-35	M8/M10	M5 x 25	1 x 20
1 1/4"	39-43	M8/M10	M5 x 25	1 x 20
1 1/2"	45-51	M8/M10	M5 x 25	1.2 x 20
55mm	54-58	M8/M10	M5 x 25	1.2 x 20
2"	60-65	M8/M10	M5 x 25	1.2 x 20
70mm	67-71	M8/M10	M5 x 25	1.2 x 20
2 1/2"	74-82	M8/M10	M6 x 30	1.5 x 25
85mm	82-89	M8/M10	M6 x 30	1.5 x 25
3"	91-98	M8/M10	M6 x 30	1.5 x 25
95mm	93-101	M8/M10	M6 x 30	1.5 x 25
105mm	102-109	M8/M10	M6 x 30	1.5 x 25
4"	109-117	M8/M10	M6 x 30	1.5 x 25
120mm	116-125	M8/M10	M6 x 30	1.5 x 25
125mm	129-141	M8/M10	M6 x 30	2 x 25
5"	136-146	M8/M10	M6 x 30	2 x 25
145mm	142-154	M8/M10	M6 x 30	2 x 25
6"	158-169	M8/M10	M6 x 30	2 x 25
175mm	166-177	M8/M10	M6 x 30	2 x 25

Surefix XL Rubber Lined Clip

For Copper, Plastic and Stainless Steel Pipes

Created on: 15 Oct 2018
Version: 3.00
Last Updated: 11 Nov 2022



Construction

Mild Steel
BZP Finish

For Use With

Copper & Plastic Tubes

Special Features

Rubber Lining tested to
DIN4109 for Acoustic Use

Pipe Size	Grip Range (mm)	Boss Type	Screw (mm)	Material (mm)
15cu	13-20	M8/M10	M5 x 25	1 x 20
18mm	17-23	M8/M10	M5 x 25	1 x 20
22cu	21-26	M8/M10	M5 x 25	1 x 20
28cu	26-25	M8/M10	M5 x 25	1 x 20
35cu	33-37	M8/M10	M5 x 25	1 x 20
42cu	40-46	M8/M10	M5 x 25	1.2 x 20
1 1/2"	48-53	M8/M10	M5 x 25	1.2 x 20
54cu	53-59	M8/M10	M5 x 25	1.2 x 20
2"	60-66	M8/M10	M5 x 25	1.2 x 20
67cu	67-77	M8/M10	M6 x 30	1.5 x 25
76cu	75-84	M8/M10	M6 x 30	1.5 x 25
3"	87-96	M8/M10	M6 x 30	1.5 x 25
95mm	94-104	M8/M10	M6 x 30	1.5 x 25
108cu	102-111	M8/M10	M6 x 30	1.5 x 25
4"	109-119	M8/M10	M6 x 30	1.5 x 25
120cu	122-135	M8/M10	M6 x 30	2 x 25
133cu	128-139	M8/M10	M6 x 30	2 x 25
5"	135-148	M8/M10	M6 x 30	2 x 25
159cu	151-164	M8/M10	M6 x 30	2 x 25
6"	158-170	M8/M10	M6 x 30	2 x 25

Heavy Duty Surefix HD Unlined Clip

For Steel Pipes & Insulated Pipe Supports

Construction

Mild Steel
 BZP Finish

For Use With

Steel & Cast Iron Tubes
 Insulated Pipe Supports



Pipe Size	Grip Range (mm)	Boss Type	Screw (mm)	Material (mm)
50nb / 2"	60-68	M12	M8 x 25	25 x 2
67mm	66-73	M12	M8 x 25	25 x 2
65nb / 2 1/2"	74-81	M12	M8 x 25	25 x 2
85mm	82-88	M12	M8 x 25	25 x 2
80nb / 3"	88-97	M12	M8 x 25	25 x 2
100mm	93-100	M12	M8 x 25	25 x 2
105mm	101-109	M12	M8 x 25	30 x 2.5
100nb / 4"	110-118	M12	M8 x 25	30 x 2.5
120mm	116-126	M12	M10 x 40	30 x .3
135mm	130-141	M12	M10 x 40	30 x .3
125nb / 5"	136-145	M12	M10 x 40	30 x .3
145mm	144-154	M12	M10 x 40	30 x .3
150nb / 6"	160-169	M12	M10 x 40	30 x .3
175mm	170-180	M16	M10 x 40	30 x .3
200nb / 8"	219-230	M16	M10 x 40	30 x .3
250nb / 10"	273-283	M16	M10 x 40	30 x .3

Heavy Duty Surefix HD Rubber Lined Clip

For Copper, Plastic and Stainless Steel Pipes

Construction

Mild Steel BZP Finish

For Use With

Copper & Plastic Tubes

Special Features

Rubber Lining tested to DIN4109 for Acoustic Use



Pipe Size	Grip Range (mm)	Boss Type	Screw (mm)	Material (mm)
67cu / 2"	60-69	M12	M8 x 25	25 x 2
76cu / 2 1/2"	75-81	M12	M8 x 25	25 x 2
80nb / 3"	83-91	M12	M8 x 25	25 x 2
108cu	102-112	M12	M8 x 25	30 x 2.5
125mm	122-138	M12	M10 x 40	30 x 3
155mm	153-164	M12	M10 x 40	30 x 3
200mm	196-209	M16	M10 x 40	30 x 3

DST 100 - Split Band

For Steel Pipes and Insulated Pipe Supports

Created on: 15 Oct 2018
Version: 3.00
Last Updated: 11 Nov 2022



Construction
Mild Steel
BZP Finish
HT Sets & Nuts

For Use With
Steel Tubes
Cast Iron Tubes
Insulated Pipe Supports

Other sizes available on request

Size ID (mm)	Size NB	Hole Centres (mm)	Bolt Size (mm)	Material Width & Thickness (mm)
65		110	M10 x 40	30 x 3
76	65NB / 2 1/2"	125	M10 x 40	30 x 3
83		131	M10 x 40	30 x 3
89	80NB / 3"	137	M10 x 40	30 x 3
95		145	M12 x 40	30 x 3
102		158	M10 x 40	30 x 3
108		163	M10 x 40	40 x 3
114	100 NB / 4"	177	M10 x 40	40 x 3
121		188	M10 x 40	40 x 3
127		194	M10 x 40	40 x 3
133		202	M10 x 40	40 x 3
140		207	M10 x 40	40 x 3
146		214	M10 x 40	40 x 3
152		222	M10 x 40	40 x 3
159		216	M12 x 40	40 x 3
168	150 NB / 6"	239	M12 x 40	40 x 3
173		243	M12 x 50	40 x 3
178		258	M12 x 50	40 x 3
186		265	M12 x 50	40 x 5
193		266	M12 x 50	40 x 5
199		278	M12 x 50	40 x 5
208		286	M12 x 50	40 x 5
216		299	M12 x 50	40 x 5
220	200 NB / 8"	301	M12 x 50	40 x 5
225		301	M12 x 50	40 x 5
232		309	M12 x 50	40 x 5
244		315	M16 x 50	40 x 5
252		319	M16 x 50	40 x 5
259		326	M16 x 50	40 x 5
268		347	M12 x 50	40 x 5
273	250 NB / 10"	357	M16 x 50	50 x 6
283		366	M16 x 50	50 x 6
290		375	M16 x 50	50 x 6
298		382	M16 x 50	50 x 6
308		402	M16 x 50	50 x 6
323	300 NB / 12"	422	M16 x 50	50 x 6

Tolerance +/-5mm

DST Group Ltd Reserves the right to alter / amend product data without prior notification

Construction

Mild Steel
 Nylon Coated Finish
 HT Sets & Nuts

For Use With

Copper Tubes
 Stainless Steel Tubes



Size ID (mm)	Size NB (cu)	Hole Centres (mm)	Bolt Size (mm)	Material Width & Thickness (mm)
15	15	50	M6 x 25	25 x 3
22	22	59	M6 x 25	25 x 3
28	28	65	M6 x 25	25 x 3
35	35	65	M6 x 25	25 x 3
42	42	82	M10 x 30	30 x 3
54	54	90	M10 x 30	30 x 3
67	67	110	M10 x 30	30 x 3
76	76	125	M10 x 30	30 x 3
108	108	163	M10 x 30	30 x 3
133	133	202	M10 x 40	40 x 3
159	159	216	M10 x 40	40 x 3

Tolerance +/-5mm

Split Band Assembly Components

DST 190 - Eye Bolt



Construction

Mild Steel BZP Finish

Sizes Available

M8, M10, M12, M16, M20
 Length - 100mm, 150mm,
 200mm

DST 200 - Link Eye



Construction

Cast Malleable Iron
 BZP Finish

Sizes Available

M8, M10, M12

DST 203 - Bow Nut



Construction

Mild Steel
 BZP Finish

Sizes Available

M10, M12, M16, M20

DST 105 - Bossed Split Band

For Steel Pipes & Insulated Pipe Supports

Created on: 15 Oct 2018
Version: 3.00
Last Updated: 11 Nov 2022



Construction

Mild Steel
BZP Finish
HT Sets & Nuts

For Use With

Steel Tubes
Cast Iron Tubes
Insulated Pipe Supports

Size ID (mm)	Size NB	Hole Centres (mm)	Boss	Bolt Size (mm)	Material Width & Thickness (mm)
65		110	M10	M10 x 40	30 x 3
76	65NB / 2 1/2"	125	M10	M10 x 40	30 x 3
83		131	M10	M10 x 40	30 x 3
89	80NB / 3"	137	M10	M10 x 40	30 x 3
95		145	M10	M10 x 40	30 x 3
102		158	M10	M10 x 40	30 x 3
108		163	M10	M10 x 40	40 x 3
114	100 NB / 4"	177	M10	M10 x 40	40 x 3
121		188	M12	M10 x 40	40 x 3
127		194	M12	M10 x 40	40 x 3
133		202	M12	M10 x 40	40 x 3
140		207	M12	M10 x 40	40 x 3
146		214	M12	M10 x 40	40 x 3
152		222	M12	M10 x 40	40 x 3
159		216	M12	M12 x 40	40 x 3
168	150 NB / 6"	239	M12	M12 x 40	40 x 3
173		243	M12	M12 x 50	40 x 3
178		258	M12	M12 x 50	40 x 3
186		265	M12	M12 x 50	40 x 5
193		266	M12	M12 x 50	40 x 5
199		278	M12	M12 x 50	40 x 5
208		286	M12	M12 x 50	40 x 5
216		299	M12	M12 x 50	40 x 5
220	200 NB / 8"	301	M12	M12 x 50	40 x 5
225		301	M12	M12 x 50	40 x 5
232		309	M12	M12 x 50	40 x 5
244		315	M12	M16 x 50	40 x 5
252		319	M12	M16 x 50	40 x 5
259		326	M12	M16 x 50	40 x 5
268		347	M12	M12 x 50	40 x 5
273	250 NB / 10"	357	M12	M16 x 50	50 x 6
283		366	M16	M16 x 50	50 x 6
290		375	M16	M16 x 50	50 x 6
298		382	M16	M16 x 50	50 x 6
308		402	M16	M16 x 50	50 x 6
323	300 NB / 12"	422	M16	M16 x 50	50 x 6

Tolerance +/-5mm

DST Group Ltd Reserves the right to alter / amend product data without prior notification

Construction

Mild Steel
 BZP Finish

For Use With

Steel Tubes
 Cast Iron Tubes
 Insulated Pipe Supports



Size ID (mm)	Size NB	Hole Centres (mm)	Max Bolt Size (mm)	Material Width & Thickness (mm)
65		119	M12	30 x 3
76	65NB / 2 1/2"	144	M12	30 x 3
83		145	M12	30 x 3
89	80NB / 3"	163	M12	30 x 3
95		159	M12	30 x 3
102		166	M12	30 x 3
108		180	M12	40 x 3
114	100 NB / 4"	204	M12	40 x 3
121		192	M12	40 x 3
127		197	M12	40 x 3
133		204	M12	40 x 3
140		220	M12	40 x 3
146		212	M12	40 x 3
152		221	M12	40 x 3
159		228	M12	40 x 3
168	150 NB / 6"	238	M12	40 x 3
173		237	M12	40 x 3
178		247	M12	40 x 3
186		258	M12	40 x 3
193		262	M12	40 x 5
199		263	M12	40 x 5
208		268	M12	40 x 5
216		286	M12	40 x 5
220	200 NB / 8"	313	M12	40 x 5
225		297	M12	40 x 5
232		305	M12	40 x 5
244		313	M12	40 x 5

All Dimensions shown are indicative and should be confirmed ahead of use



Construction

Mild Steel

Nylon Coated Finish

For Use With

Copper Tubes

Stainless Steel Tubes

Size ID (mm)	Size NB (cu)	Hole Centres (mm)	Bolt Size (mm)	Material Width & Thickness (mm)
15	15	53	8	25 x 3
22	22	60	8	25 x 3
28	28	71	8	25 x 3
35	35	74	8	25 x 3
42	42	94	12	30 x 3
54	54	108	12	30 x 3
67	67	120	12	30 x 3
76	76	130	12	30 x 3
108	108	162	12	30 x 3
133	133	197	14	40 x 3
159	159	223	14	40 x 3

All Dimensions shown are indicative and should be confirmed ahead of use

DST 170 - Filbow Clamp

LPCB Approved for Steel Pipes



Construction

Cold Rolled Mild Steel

Pre-Galv Finish

For Use With

Steel Tubes

Nominal Imperial	OD (mm)	Height	Width (mm)	Hole Ø	Material (mm)
1/2"	28	51.5	36.5	10.5	25 x 1.2
3/4"	30	53.5	37.5	10.5	25 x 1.2
1"	36	65.5	46.5	10.5	25 x 1.2
1 1/4"	46	79.9	55.7	10.5	25 x 1.2
1 1/2"	52	85.9	58.7	10.5	25 x 1.2
2"	66	99.9	65.7	10.5	25 x 1.2
2 1/2"	78	116	75.5	10.5	25 x 1.5
3"	92	132	84.5	10.5	25 x 1.5
4"	116	167.5	107.5	10.5	25 x 2
5"	142	200	126.5	13	32 x 2.5
6"	170	238	150.5	13	32 x 3

DST Group Ltd Reserves the right to alter / amend product data without prior notification

Properties

CFC/HCFC-free with zero Ozone Depletion Potential (ODP)

High Closed Cell Content

Inert Bore Coated for use on all Pipes Including Copper

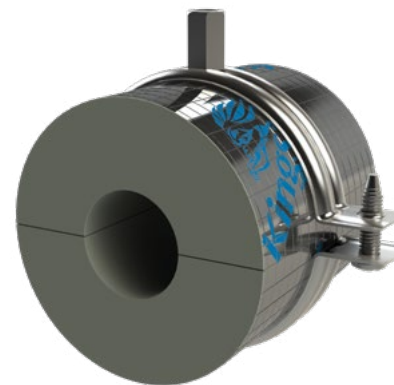

General Physical Properties (Metric)						
Property	Test Method	Unit	Typical Value			
Nominal Density (Min)	(EN ISO 845) / (ASTM D 1622)	Kg/m ³	37	60	80	120
Thermal Conductivity (Min)	(EN 12667) / (ASTM C 518)	W/m·K	0.021	0.029	0.03	0.032
Colour			Grey	Grey	Grey	Grey
Operating Temperature Limits	Upper Limit	°C	120	120	120	120
	Lower Limit	°C	-180	-180	-180	-180
Minimum Compressive Strength at +23 °C	(EN 826) / (ASTM D 1621) Parallel	kPa	150	320	590	1000
		Perpendicular	100	170	440	800

Fire Test Specifications					
Fire Test	Test Method	Specification			
Fire Propagation	BS 476-6: 1989	Index of Performance (I) not exceeding 12 and sub index (i1) not exceeding 6*			
Surface Spread of Flame	BS 476-7: 1997	Class 1*	Class 1*	Class 1*	Class 1*
Vertical Burning	DIN 4102-1: 1998	B2	B2	B2	B2

These test results combined enable a Class 0 classification to the Building Regulations in England & Wales, Northern Ireland and the Republic of Ireland, and a Low Risk classification to the Building Standards in Scotland. These tests were conducted on samples of 25mm/1" thickness faced with a reinforced aluminium foil vapour barrier jacket.

Mineral Wool Pipe Supports

Properties

Non-combustable stone wool, suitable for use on steel & copper

Suitable for use up to 250°C

Foil faced for vapour control



Product Information		
Pipe Support Length	OD Range (mm)	Thickness Range (mm)
80mm long:	17-135	20-80
	140-160	25-60
100mm long	89-135	100
	140-160	70-100
	169-210	25-100

*Other sizes may be available please contact DST Sales office for further information.

** Product length varies to accommodate larger hanger support clips.



Material

Hardwood - Kiln Dried

Length

100mm (Tolerance of -1.5mm Maximum)

Thickness

15, 20, 25, 30, 40, 50, 63, 75 (Other Thicknesses available upon request)

Tolerance on thickness not exceeding +/-1.5mm

Bore Sizes

Steel - 15nb, 20nb, 25nb, 32nb, 40nb, 50nb, 65nb, 80nb, 100nb, 125nb, 150nb, 200nb, 250nb, 300nb

Copper - 15cu, 22cu, 28cu, 35cu, 42cu, 54cu, 67cu, 76cu, 108cu, 133cu, 159cu.

Plastic - Available upon request.

Calcium Silicate Insulation

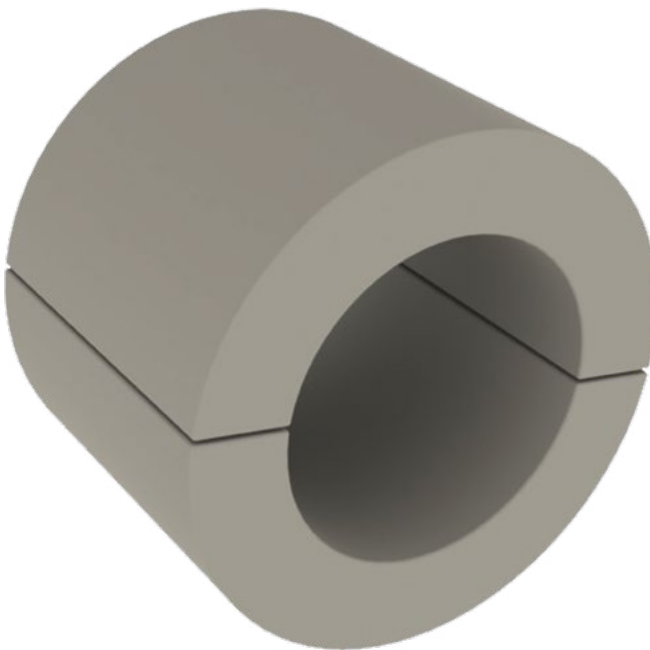

Description

A tough and durable calcium silicate insulation offering exceptional thermal efficiency on hot process applications. Non combustible, it is an inert material, containing no asbestos.

Appearance

White/off white rigid insulation.

Product Application

Calcium Silicate is an ideal insulation material for high temperature pipes. Used throughout the Petrochemical, Power Generation, Furnace and primary aluminium sectors, Calcium Silicate combines excellent thermal efficiency with high compressive strength, able to withstand foot traffic.

Typical Product Performance		
	Insulite 650	Insulite 1050
Maximum Service Temp:	650°C	1050°C
Age Density:	220kg/m ³	265kg/m ³
Compressive Strength:	0.8 Mpa	1.8Mpa
Combustibility:	Non-comb	Non-comb
Linear Shrinkage:	<2%	1.4%
Flexural Strength:	0.4 Mpa	0.8 Mpa
Thermal Conductivity @ 200°C	0.06W/mK	0.07W/mK

Construction

Mild Steel
 BZP Finish

For Use With

Steel Tubes
 Cast Iron Tubes
 Insulated Pipe Supports



Size ID (mm)	Rod Dia (mm)	Size NB (mm)	Rod Dia (mm)
46	M10		
51	M10		
56	M10		
62	M10		
67	M10		
72	M10		
78	M10		
85	M10		
91	M10	15	M6
97	M10	20	M6
104	M10	25	M6
110	M10	32	M10
116	M10	40	M10
123	M10	50	M10
129	M10	65	M10
135	M12	80	M12
141	M12	100	M12
146	M12	125	M12
150	M12	150	M12
154	M12	200	M16
161	M12	250	M16
166	M12	300	M16
170	M12		
175	M12		
180	M12		
185	M12		
191	M12		
195	M12		
201	M12		
208	M12		
212	M12		
216	M12		
222	M12		
228	M12		
234	M12		
240	M12		
246	M12		
254	M16		
260	M16		
264	M16		
268	M16		
275	M16		
285	M16		
292	M16		
301	M16		
310	M16		

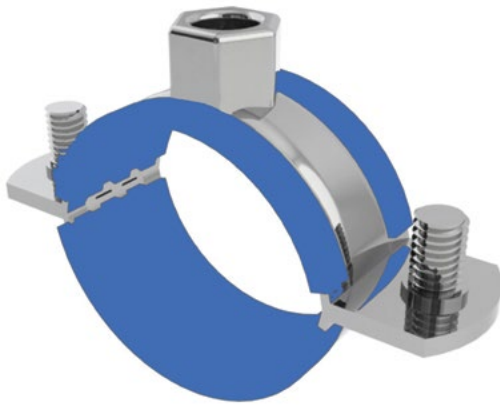

Construction
Mild Steel
BZP Finish

For Use With
Copper & Plastic Tubes

Special Features
Silicon Low Friction Lining

Size (mm)	Boss Size	Material Type	Temperature Limits °C	Part Number
16	M10	20 x 1	-10 - +90	GC16
20	M10	20 x 1	-10 - +90	GC20
25	M10	20 x 1	-10 - +90	GC25
32	M10	20 x 1	-10 - +90	GC32
40	M10	20 x 1.2	-10 - +90	GC40
50	M10	20 x 1.2	-10 - +90	GC50
56	M10	20 x 1.2	-10 - +90	GC56
63	M10	25 x 1.5	-10 - +90	GC63

Expansion Products DSTMS1 & 2 Modular Slide Guide

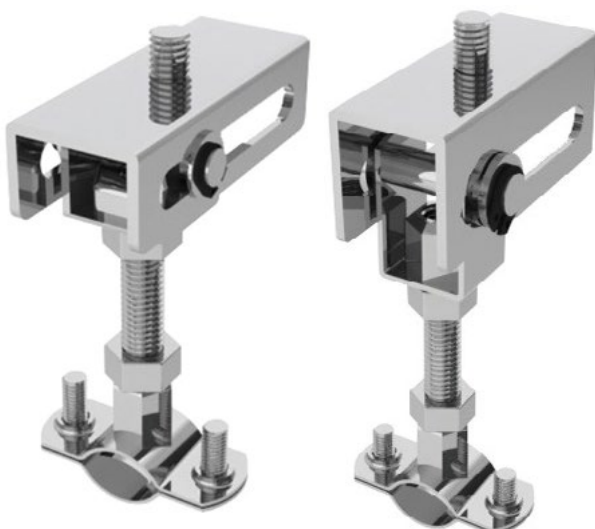

MS1 Slimline

MS2 Standard

Construction
Mild Steel
BZP Finish

For Use With
Unlined & Rubber Lined
Brackets to Create a Guided
System

Type	Internal Thread	Max Travel	SWL
MS1	M10	50mm	0.25kN
MS2	M8/M10	50mm	0.25kN

DST - Ball Hanger



Size	Movement	SWL
M8	+/-5°	0.15kN
M10	+/-5°	0.20kN
M12	+/-5°	0.25kN

Construction
Mild Steel BZP Finish

For Use With
Unlined & Lined Clip Range &
Hanging brackets to reduce
drop rod lateral loads

Group Ltd Reserves the right to alter / amend product data without prior notification

Construction

Mild Steel BZP Finish
 Low Friction Slide Insert

For Use With

Unlined & Rubber Lined Clips
 Surefix HD on Larger Sizes



Special Features

Dual & Triple Bossed
 Lockable for transport

Type	Internal Thread	External Thread	Max Travel	SWL
LF1	M8/M10	N/A	65mm	0.5kN
LF2-1	M10	M16	90mm	2.0kN
LF2-2	M10	M16	120mm	2.0kN
LF3-1	M12/M16	1/2"	120mm	6.0kN
LF3-2	M12/M16	1/2"	135mm	6.0kN

				LF1		LF2-*		LF3-*	
									
									
Steel	Steel	CU							
NB	NB	OD	OD	LF1-***UL	LF1-***RL	LF2-*-***UL	LF2-*-RL	LF3-*-UL	LF3-*-RL
		15		LF1-015RL		LF2-*-015RL		LF3-*-015RL	
		18		LF1-018UL	LF1-018RL	LF2-*-018UL	LF2-*-018RL	LF3-*-018UL	LF3-*-018RL
1/2"	15	21	22	LF1-021UL	LF1-022RL	LF2-*-021UL	LF2-*-022RL	LF3-*-021UL	LF3-*-022RL
3/4"	20	27	28	LF1-027UL	LF1-028RL	LF2-*-027UL	LF2-*-028RL	LF3-*-027UL	LF3-*-028RL
1"	25	34	35	LF1-034UL	LF1-035RL	LF2-*-034UL	LF2-*-035RL	LF3-*-034UL	LF3-*-035RL
1 1/4"	32	42	42	LF1-042UL	LF1-042RL	LF2-*-042UL	LF2-*-042RL	LF3-*-042UL	LF3-*-042RL
1 1/2"	40	48		LF1-048UL	LF1-048RL	LF2-*-048UL	LF2-*-048RL	LF3-*-048UL	LF3-*-048RL
		54		LF1-054RL		LF2-*-054RL		LF3-*-054RL	
2"	50	60		LF1-060UL	LF1-060RL	LF2-*-060UL	LF2-*-060RL	LF3-*-060UL	LF3-*-060RL
		67				LF2-*-067RL		LF3-*-067RL	
2 1/2"	65	76	76			LF2-*-076UL	LF2-*-076RL	LF3-*-076UL	LF3-*-076RL
3"	80	89				LF2-*-089UL	LF2-*-089RL	LF3-*-089UL	LF3-*-089RL
		108				LF2-*-108RL		LF3-*-108RL	
4"	100	114				LF2-*-114UL	LF2-*-114RL	LF3-*-114UL	LF3-*-114RL
HEAVY DUTY									
		133				LF3-*-***HDUL	LF3-*-***HDRL	LF3-*-133HDUL	LF3-*-133HDRL
5"	125	140				LF3-*-140HDUL	LF3-*-140HDRL	LF3-*-140HDUL	LF3-*-140HDRL
		159						LF3-*-159HDUL	LF3-*-159HDRL
6"	150	168				LF3-*-168HDUL	LF3-*-168HDRL	LF3-*-168HDUL	LF3-*-168HDRL
8"	200	220				LF3-*-220HDUL	LF3-*-220HDRL	LF3-*-220HDUL	LF3-*-220HDRL
10"	250	273				LF3-*-273HDUL	LF3-*-273HDRL	LF3-*-273HDUL	LF3-*-273HDRL
MAXIMUM TRAVEL				60mm		LF2-1 90mm	LF2-2 120mm	LF3-1 120mm	LF3-2 135mm

DST AAB - Adjustable Anchor Bracket

For Steel, Copper & Stainless Steel Pipes

Created on: 15 Oct 2018
 Revision: 3.00
 Last Updated: 11 Nov 2022

The DST AAB Adjustable Anchor Bracket banks either 2 or 3 Split split bands on a set of steel cleat which can be adjusted for height and fall.

As a standard upto 54mm od bands will be powder coated, with larger sizes BZP for steel pipes or powder coated for copper & stainless steel.

Other band combinations are available upon request including brass, stainless steel & thicker profile steel bands.

Construction

Mild Steel BZP Finish

High Tensile BZP Set Screws

For Use With

Copper, Steel & Stainless Steel pipes

Special Features

Adjustable Height & Angle to facilitate fall in pipework.

Pipe Size	Band Material	Band QTY	Finish	SWL (kN)	Part Code	Torque Settings
15	25 x 3	2	Black Powder Coat	2.0	AB1015	40nm
22	25 x 3	2	Black Powder Coat	2.0	AB1022	40nm
28	25 x 3	2	Black Powder Coat	2.0	AB1028	40nm
15	25 x 3	2	Black Powder Coat	2.0	AB1022	40nm
20	25 x 3	2	Black Powder Coat	2.0	AB1028	40nm
25	25 x 3	2	Black Powder Coat	2.0	AB1035	40nm
15	25 x 3	3	Black Powder Coat	3.0	AB2015	40nm
22	25 x 3	3	Black Powder Coat	3.0	AB2022	40nm
28	25 x 3	3	Black Powder Coat	3.0	AB2028	40nm
35	25 x 3	3	Black Powder Coat	3.0	AB2035	40nm
42	30 x 3	3	Black Powder Coat	6.5	AB2042	60nm
54	30 x 3	3	Black Powder Coat	6.5	AB2054	60nm
67	30 x 3	3	Black Powder Coat	6.5	AB2067	60nm
76	30 x 3	3	Black Powder Coat	6.5	AB2076	60nm
108	40 x 3	3	Black Powder Coat	8.0	AB2108	60nm
133	40 x 3	3	Black Powder Coat	8.0	AB2133	60nm
159	40 x 3	3	Black Powder Coat	8.0	AB2159	60nm
15	25 x 3	3	Black Powder Coat	3.0	AB2022	40nm
20	25 x 3	3	Black Powder Coat	3.0	AB2028	40nm
25	25 x 3	3	Black Powder Coat	3.0	AB2035	40nm
32	25 x 3	3	Black Powder Coat	3.0	AB2042	60nm
40	30 x 3	3	Black Powder Coat	6.5	AB2040	60nm
50	30 x 3	3	BZP	6.5	AB2050	60nm
65	30 x 3	3	BZP	6.5	AB2065	60nm
80	30 x 3	3	BZP	6.5	AB2080	60nm
100	40 x 3	3	BZP	8.0	AB2100	60nm
125	40 x 3	3	BZP	8.0	AB2125	60nm
150	40 x 3	3	BZP	8.0	AB2150	60nm



Construction

Mild Steel BZP or Powder Finish
 High Tensile BZP Set Screws

For Use With

Copper, Steel & Stainless Steel
 pipes

Special Features

Fabricated on Site using DST100
 or DST130 Split Bands

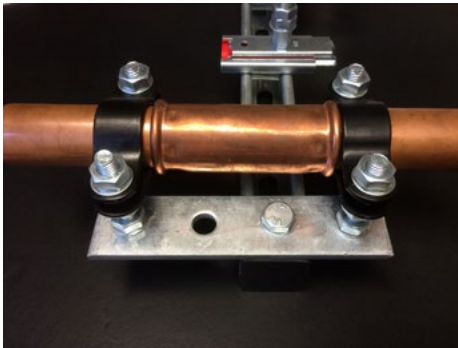

The Slip Anchor and Band Anchor are an effective way of installing anchors on site with relatively low costs.

The idea is to use multiple split bands to ensure a firm mechanical grip on the pipework. In the case of the Slip Anchor, a band is placed on either side of a slip coupling to add a failsafe mechanism. The coupling could be any type of slip coupling, but not a pipe connector unless its a welded flange.

Pipe Size	Band Material	No Of Bands	Finish	Anchor Type
15	25 x 3	2	Black Powder Coat	Slip
22	25 x 3	2	Black Powder Coat	Slip
28	25 x 3	2	Black Powder Coat	Slip
35	25 x 3	2	Black Powder Coat	Slip
42	30 x 3	2	Black Powder Coat	Slip
54	30 x 3	2	Black Powder Coat	Slip
67	30 x 3	2	Black Powder Coat	Slip
76	30 x 3	2	Black Powder Coat	Slip
108	40 x 3	2	Black Powder Coat	Slip

15	25 x 3	2	Black Powder Coat	Slip
20	25 x 3	2	Black Powder Coat	Slip
25	25 x 3	2	Black Powder Coat	Slip
32	25 x 3	2	Black Powder Coat	Slip
40	30 x 3	2	Black Powder Coat	Slip
50	30 x 3	2	BZP	Slip
65	30 x 3	2	BZP	Slip
80	30 x 3	2	BZP	Slip
100	40 x 3	2	BZP	Slip

Pipe Size	Band Material	No Of Bands	Finish	Anchor Type
15	25 x 3	2	Black Powder Coat	Band
22	25 x 3	2	Black Powder Coat	Band
28	25 x 3	2	Black Powder Coat	Band
35	25 x 3	2	Black Powder Coat	Band
42	30 x 3	2	Black Powder Coat	Band
54	30 x 3	3	Black Powder Coat	Band
67	30 x 3	3	Black Powder Coat	Band
76	30 x 3	3	Black Powder Coat	Band
108	40 x 3	3	Black Powder Coat	Band

15	25 x 3	2	Black Powder Coat	Band
20	25 x 3	2	Black Powder Coat	Band
25	25 x 3	2	Black Powder Coat	Band
32	25 x 3	2	Black Powder Coat	Band
40	30 x 3	2	Black Powder Coat	Band
50	30 x 3	3	BZP	Band
65	30 x 3	3	BZP	Band
80	30 x 3	3	BZP	Band
100	40 x 3	3	BZP	Band

DST Group Ltd Reserves the right to alter / amend product data without prior notification



Construction
 Mild Steel
 HT Sets & Nuts

For Use With
 Steel Tubes
 Cast Iron Tubes
 Insulated Pipe Supports

Nominal Imperial	Pipe Size Metric (NB)	Material A (mm)	Material B (mm)	Bolt Size
1/2"	15	30 x 3	30 x 5	M10 x 30
3/4"	20	30 x 3	30 x 5	M10 x 30
1"	25	30 x 3	30 x 5	M10 x 30
1 1/4"	32	30 x 3	30 x 5	M10 x 30
1 1/2"	40	30 x 3	30 x 5	M10 x 30
2"	50	30 x 3	30 x 5	M10 x 30
2 1/2"	65	30 x 3	30 x 5	M10 x 30
3"	80	40 x 3	40 x 5	M12 x 40
4"	100	40 x 3	40 x 5	M12 x 40
5"	125	50 x 3	50 x 6	M16 x 50
6"	150	50 x 3	50 x 6	M16 x 50
8"	200	50 x 6	50 x 8	M16 x 50

DST 115 Hanging Roller



Construction
 Mild Steel

For Use With
 Steel Tubes
 Cast Iron Tubes
 Insulated Pipe Supports

Nominal Imperial	Pipe Size Metric (NB)	Hole Ø	Material (mm)
1/2"	15	12	30 x 3
3/4"	20	12	30 x 3
1"	25	12	30 x 3
1 1/4"	32	12	30 x 3
1 1/2"	40	12	30 x 3
2"	50	12	30 x 3
2 1/2"	65	12	30 x 3
3"	80	14	40 x 3
4"	100	14	40 x 3
5"	125	19	50 x 6
6"	150	19	50 x 6
8"	200	23	60 x 8

Construction

Mild Steel
 HT Sets & Nuts

For Use With

Steel Tubes
 Cast Iron Tubes
 Insulated Pipe Supports



Nominal Imperial	Pipe Size Metric (NB)	Material (mm)	Fixing Holes
1/2"	15	30 x 5	12
3/4"	20	30 x 5	12
1"	25	30 x 5	12
1 1/4"	32	30 x 5	12
1 1/2"	40	30 x 5	12
2"	50	30 x 5	12
2 1/2"	65	30 x 5	12
3"	80	40 x 5	12
4"	100	40 x 5	12
5"	125	50 x 6	14
6"	150	50 x 6	14
8"	200	50 x 8	19

DST 134 S/E 'U' Bolt

For Copper Pipes

Construction

Mild Steel
 Nylon Coated Finish

For Use With

Copper Tubes
 Stainless Steel Tubes



All Dimensions shown are indicative and should be confirmed ahead of use

Size ID (mm)	Size NB (cu)	Rod Ø	Leg Centres	Thread Length Standard	Thread Length Extended
15	15	M6	22	30	75
22	22	M6	29	30	75
28	28	M6	35	30	75
35	35	M6	42	30	85
42	42	M8	52	40	85
54	54	M8	64	40	85
67	67	M8	76	40	85
76	76	M10	88	40	85
108	108	M10	120	40	85
133	133	M10	145	40	85
159	159	M12	173	40	85

DST Group Ltd Reserves the right to alter / amend product data without prior notification

DST 240 G/M/B - Munsen Rings

Construction

Metric Threads



240G = Galvanised 240M = Malleable Iron 240B = Cast Brass

DST 241 G/M/B - School Board Clips



241G = Galvanised 241M = Malleable Iron 241B = Cast Brass

DST 242 G/M/B - Backplates



242G = Galvanised 242M = Malleable Iron 242B M10 Male & Female Threads

High Tensile Nut

Construction

Steel Grade 8.8 DIN934.
Cold Formed.
BZP Finish

Sizes Available

M4, M5, M6, M8, M10,
M12, M16, M20, M24



Wedge Nut

Construction

Mild Steel
BZP Finish

Sizes Available

M6, M8, M10 & M12

Construction

Mild Steel
BZP Finish

Sizes Available

M8, M10 & M12

Flange Clamp



STRUT: Plain or Slotted

- 41 x 41 x 6m
- 41 x 41 x 3m
- 41 x 21 x 6m
- 41 x 21 x 3m
- 41 x 41 x 6m Back to Back
- 41 x 41 x 3m Back to Back
- 41 x 21 x 6m Back to Back
- 41 x 21 x 3m Back to Back

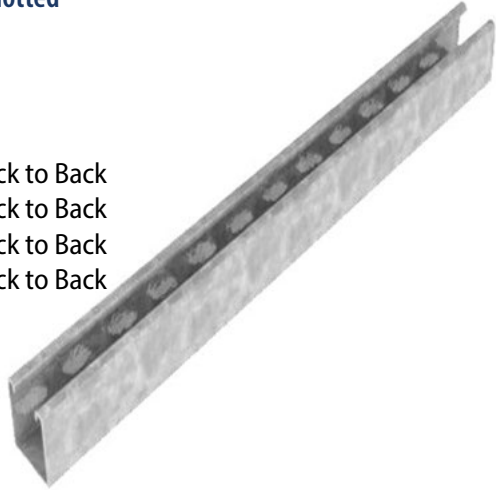

CANTILEVER ARMS

- 150mm Long
- 300mm Long
- 450mm Long
- 600mm Long
- 750mm Long
- 900mm Long

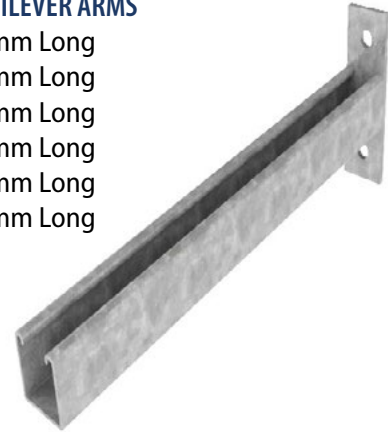

STUDDING 1m & 3m



NUTS

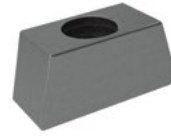

WEDGE NUTS



WASHERS



BOLTS & SETS



PURLIN CLIPS



CHANNEL NUTS

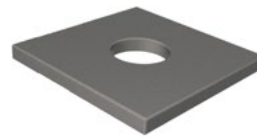

DST01



DST02

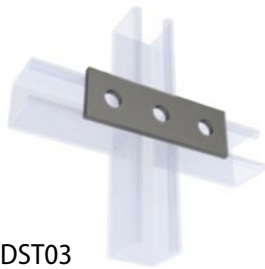

DST03

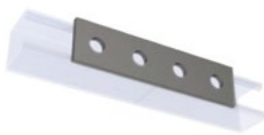

DST04



DST05



DST06



DST07



DST08



DST09
41 x 21

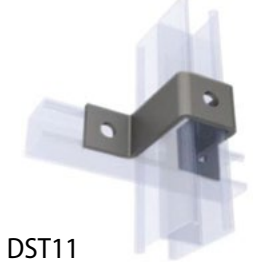

DST10
41 x 41



DST12



DST13

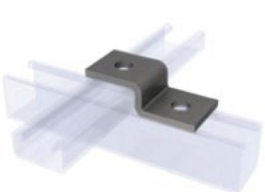

DST14

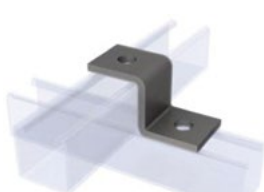

DST15

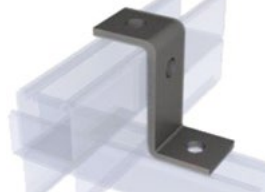

DST16



DST17

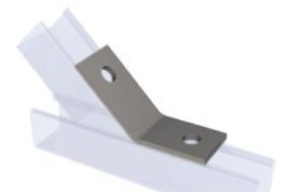

DST18

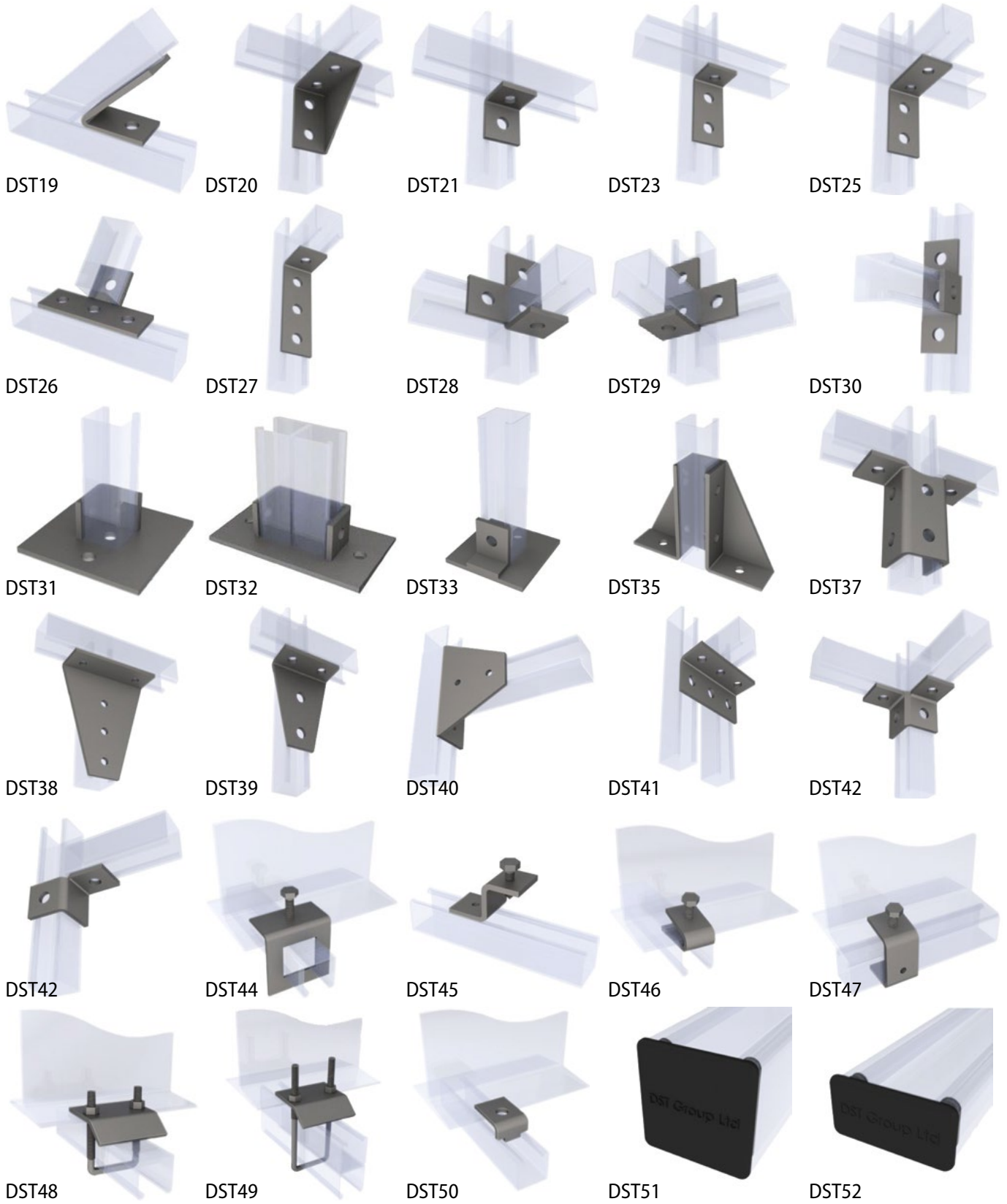

DST Threaded Rod

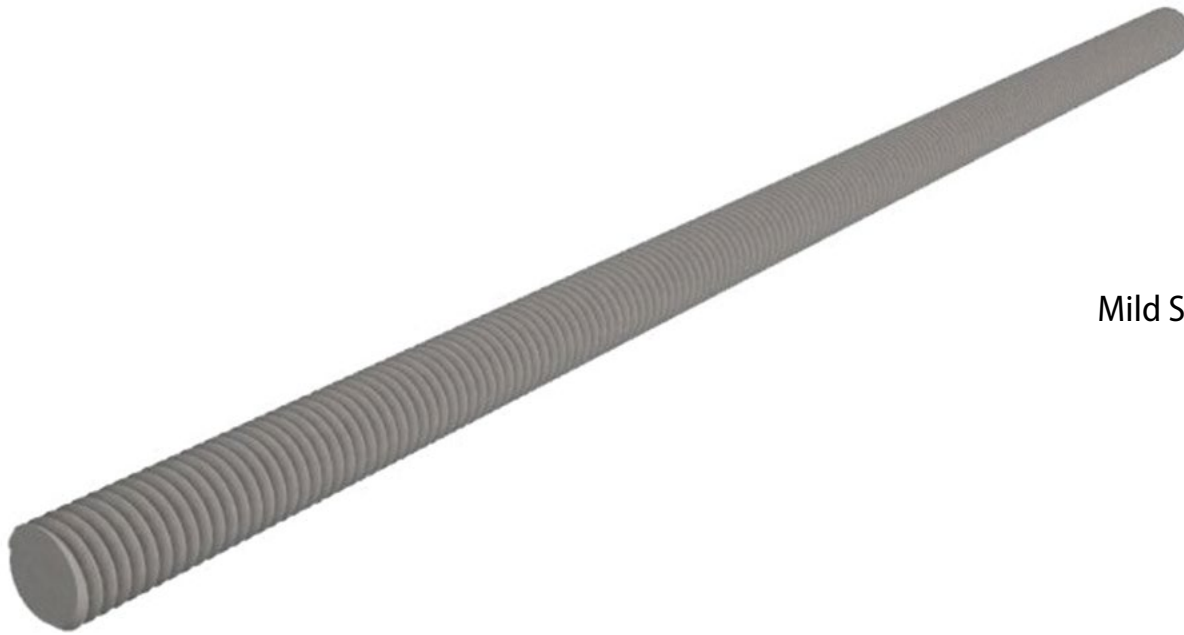

Construction

Mild Steel 4.8 Grade to
DIN EN20891.-1

BZP Finish

Standard Lengths	Cut Lengths (mm)			
Size	Size	Size	Size	Size
M6 x 1m	M10 x 25	M10 x 160	M10 x 295	M10 x 430
M6 x 3m	M10 x 30	M10 x 165	M10 x 300	M10 x 435
M8 x 3m	M10 x 35	M10 x 170	M10 x 305	M10 x 440
M10 x 1m	M10 x 40	M10 x 175	M10 x 310	M10 x 445
M10 x 3m	M10 x 45	M10 x 180	M10 x 315	M10 x 450
M12 x 1m	M10 x 50	M10 x 185	M10 x 320	M10 x 455
M16 x 1m	M10 x 55	M10 x 190	M10 x 325	M10 x 460
M16 x 3m	M10 x 60	M10 x 195	M10 x 330	M10 x 465
M20 x 1m	M10 x 65	M10 x 200	M10 x 335	M10 x 470
M20 x 3m	M10 x 70	M10 x 205	M10 x 340	M10 x 475
M24 x 1m	M10 x 75	M10 x 210	M10 x 345	M10 x 480
M24 x 3m	M10 x 80	M10 x 215	M10 x 350	M10 x 485
	M10 x 85	M10 x 220	M10 x 355	M10 x 490
	M10 x 90	M10 x 225	M10 x 360	M10 x 495
	M10 x 95	M10 x 230	M10 x 365	M10 x 500
	M10 x 100	M10 x 235	M10 x 370	M10 x 505
	M10 x 105	M10 x 240	M10 x 375	M10 x 510
	M10 x 110	M10 x 245	M10 x 380	M10 x 515
	M10 x 115	M10 x 250	M10 x 385	M10 x 520
	M10 x 120	M10 x 255	M10 x 390	M10 x 525
	M10 x 125	M10 x 260	M10 x 395	M10 x 530
	M10 x 130	M10 x 265	M10 x 400	M10 x 535
	M10 x 135	M10 x 270	M10 x 405	M10 x 540
	M10 x 140	M10 x 275	M10 x 410	M10 x 545
	M10 x 145	M10 x 280	M10 x 415	M10 x 550
	M10 x 150	M10 x 285	M10 x 420	M10 x 555
	M10 x 155	M10 x 290	M10 x 425	M10 x 560

Tolerance +/-5mm

DST Group Ltd Reserves the right to alter / amend product data without prior notification

Expansion & Anti-Vibration

Expansion & Anti-Vibration

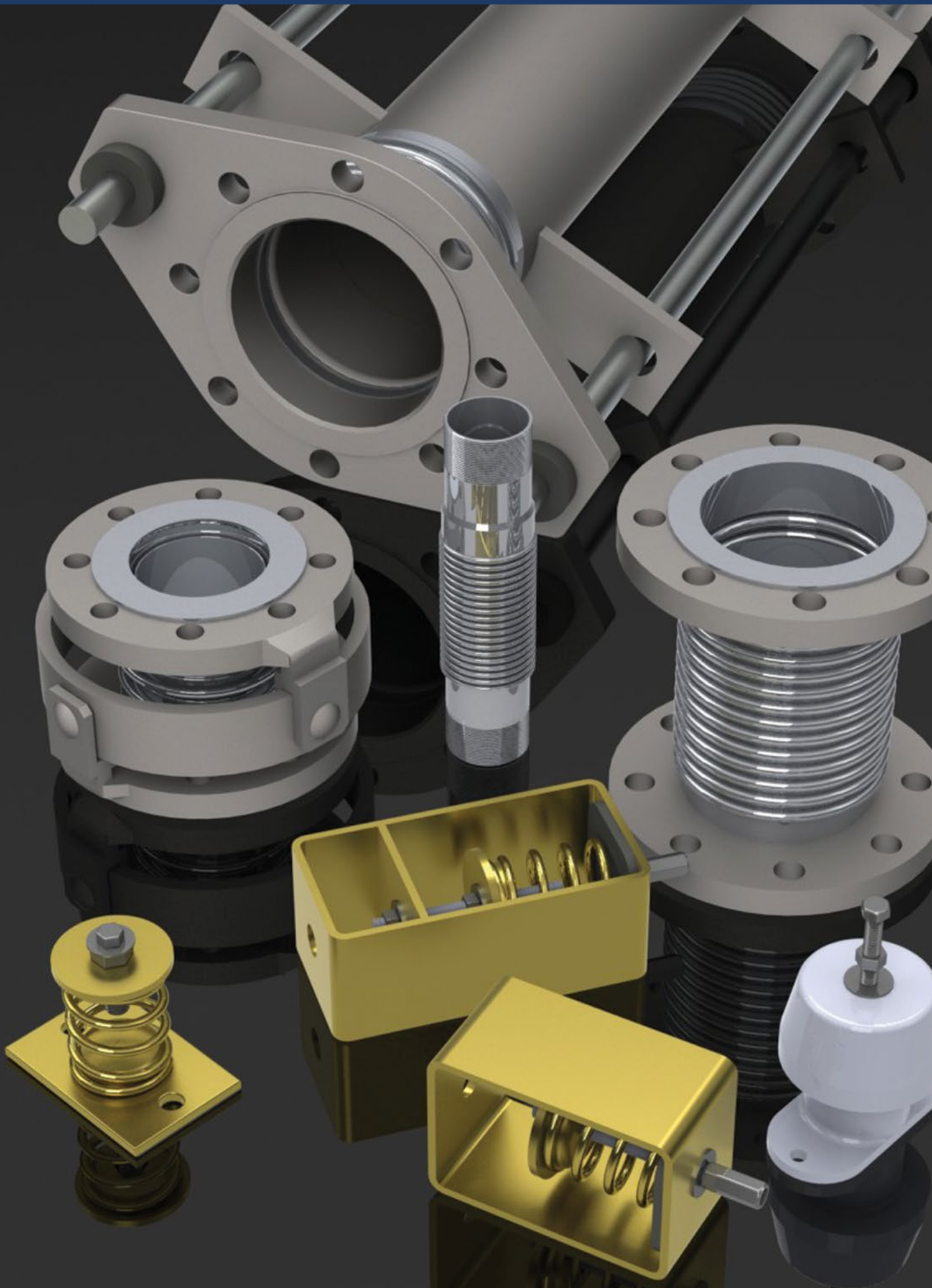

31	AX2 Axial Bellows
32	AX1 Axial Bellows
33	AX3 Screwed Axial Bellows
34	AX3(SPE) Axial Bellows c/w Stainless Pipe Ends
35	FA1 & FA2 Fully Articulated Bellows
36	AN1 & AN2 Angular Bellows
37	GI1 & GI2 Gimbal Bellows
38	Untied EPDM Pump Flexibles
39	Tied EPDM Pump Flexibles
40	Screwed EPDM Pump Flexibles
43	FA3 Stainless Steel Pump Flexibles
44	EPDM Hoses
45	Stainless Steel Hoses
47	Inertia Bases
48	Enclosed Spring Mounts
49	Restrained Spring Mounts
50	Open Spring Mounts
51	Neprene Mounts and Hangers
52 -53	Spring Hangers
54	Air & Dirt Separators
56	Dosing Pots

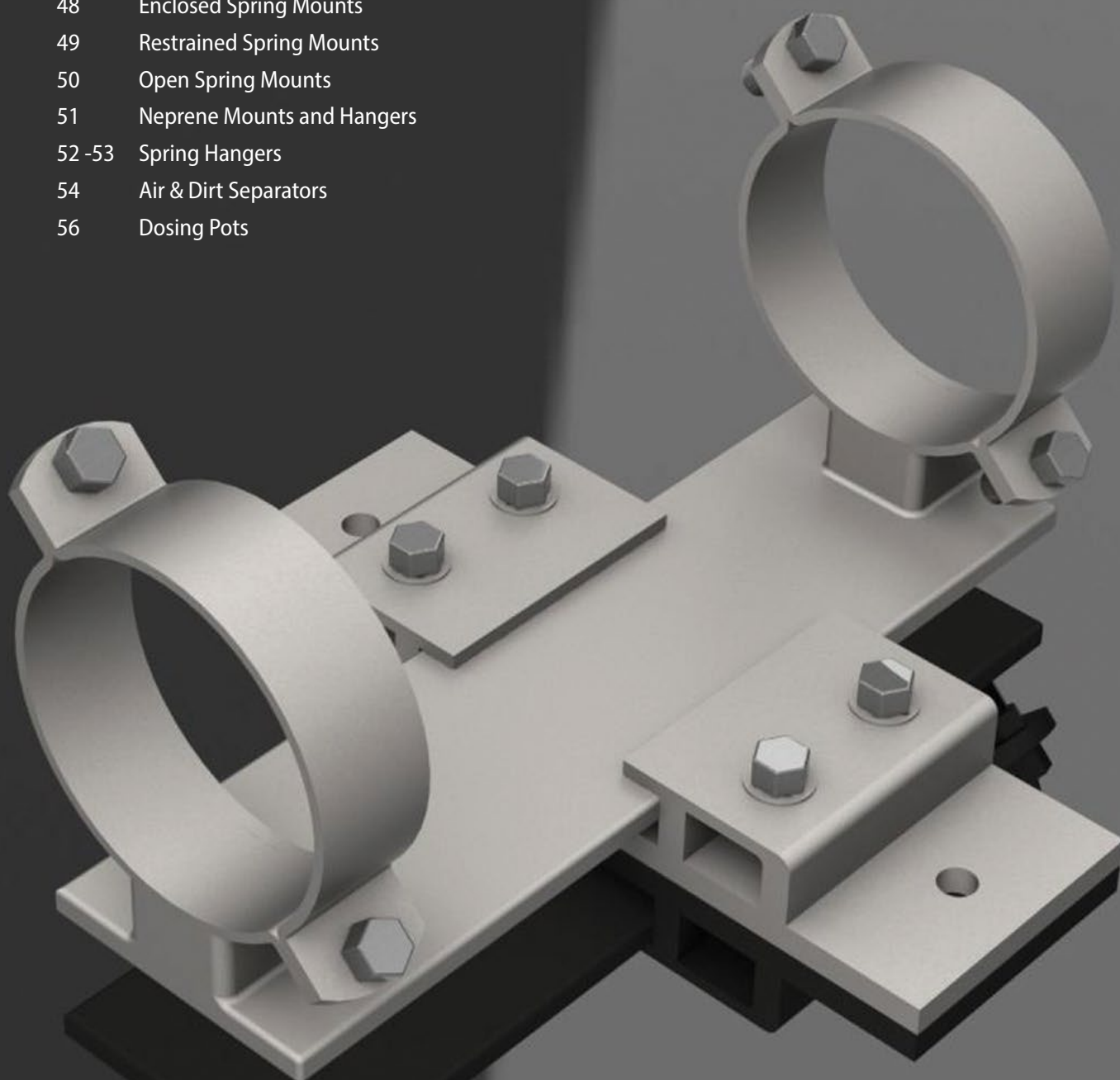

Key Points

- Require Full Guiding
- Available for any Temperature or Pressure
- Supplied with CE Certs where Applicable
- Internal Flow Liner as Standard
- Bellows are Pre-Cold Drawn

DST Type AX2 Axial Bellows

Designed to accept linear expansion on copper and stainless steel pipe systems.

Standard product details are shown below, although these may vary dependant upon application and PED requirements.



Material Specification

- Flanges: Carbon Steel PN16 With Stainless steel facings (Stainless steel to all wetted areas)
- Convolutions: 316 Stainless Steel
- Internal Sleeve: 316 Stainless Steel

Working Conditions

- Pressure: 16 Bar
- Temperature: 120 Degrees C
- Test: 1.5x Working

PED Requirements

All Bellows supplied by DST Group Ltd are manufactured and certified in accordance with EU PED Legislation and as such carry the relevant CE certification where required.

Size (mm)	Axial Compression (mm)	Installed Length	Effective Area cm ²	Force to Compress N/mm	Part Number
32nb / 35cu	30	130	12.8	37	AX2/032/PN16
40nb / 42cu	30	130	19.0	37	AX2/040/PN16
50nb / 54cu	50	225	35.6	55	AX2/050/PN16
65nb / 67cu	50	225	46.5	87	AX2/065/PN16
80nb / 76cu	50	230	61.7	90	AX2/080/PN16
100nb / 108cu	50	230	103.2	116	AX2/100/PN16
125nb / 133cu	60	240	177.5	118	AX2/125/PN16
150nb / 159cu	60	240	253.6	166	AX2/150/PN16
200nb	70	275	453.5	176	AX2/200/PN16
250nb	70	280	684.6	276	AX2/250/PN16

The anchor loads generated by this type of Axial Expansion Compensator are high. A bracket guide with a low frictional resistance should be used.

Please note these units are not suitable for use on a drop rod system and need to be suitably guided (e.g. DST LF Slide Guide or DST 253 Slide Guide). Please consult the Expansion Compensator Application Guide for positioning of anchor points and subsequent support centres. (See page 116)

Primary Pipe Guide Spacings

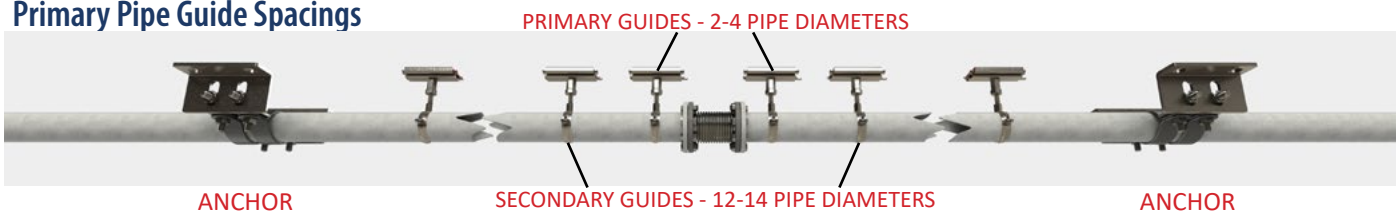

DST Group Ltd Reserves the right to alter / amend product data without prior notification

Key Points

Require Full Guiding

Available for any Temperature or Pressure

Supplied with CE Certs where Applicable

Internal Flow Liner as Standard

Bellows are Pre-Cold Drawn

DST Type AX1 Axial Bellows

Designed to accept linear expansion on carbon steel and stainless steel pipe systems.

Standard product details are shown below, although these may vary dependant upon application and PED requirements.

Material Specification

Flanges: Carbon Steel PN16 With Stainless steel facings
(Stainless steel to all wetted areas)

Convolutions: 321 Stainless Steel (Available in 316 stainless steel for potable water)

Internal Sleeve: 321 Stainless Steel (Available in 316 or 304 stainless steel for potable water)

Working Conditions

Pressure: 16 Bar

Temperature: To suit customer requirements

Test: 1.5x Working

PED Requirements

All Bellows supplied by DST are manufactured and certified in accordance with EU PED Legislation and as such carry the relevant CE certification where required.

Size (mm)	Axial Compression (mm)	Installed Length	Effective Area cm ²	Force to Compress N/mm	Part Number
32nb	30	210	15	61	AX1/032/PN16
40nb	30	215	22	78	AX1/040/PN16
50nb	50	233	40	135	AX1/050/PN16
65nb	50	233	62	107	AX1/065/PN16
80nb	50	233	81	295	AX1/080/PN16
100nb	50	233	127	379	AX1/100/PN16
125nb	60	336	196	295	AX1/125/PN16
150nb	60	336	273	355	AX1/150/PN16
200nb	70	372	470	284	AX1/200/PN16
250nb	70	372	700	354	AX1/250/PN16
300nb	70	372	958	420	AX1/300/PN16

The anchor loads generated by using this type of Axial Expansion Compensator are high. A guide bracket with a low frictional resistance should be used.

Please note these units are not suitable for use on a drop rod system and need to be suitably guided (e.g. DST 253 Slide Guide or DST 114 Roller Chair and Guide). Please consult the Expansion Compensator Application Guide for positioning of anchor points and subsequent support centres. (See Page 114)

Primary Pipe Guide Spacings.



DST Group Ltd Reserves the right to alter / amend product data without prior notification

Key Points

- Require Full Guiding
- Available in any Temperature or Pressure
- Supplied with CE certs where Applicable
- Internal Flow liner as Standard
- Bellows are Pre-Cold Drawn



Material Specification

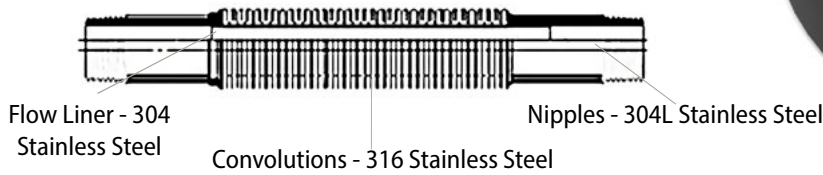

DST Type AX3 Axial Bellows

Designed to accept linear expansion on Steel & Copper pipe systems.

Working Conditions

Pressure: Standard 10 Bar (Upto 16 Bar - Dependant on PED Conditions)
 Temperature: 120 Degrees C
 Test: 1.5x Working

PED Requirements

All Bellows supplied by DST Group Ltd are manufactured and certified in accordance with EU PED Legislation and as such carry the relevant CE certification where required.

Size (mm)	Axial Compression (mm)	Installed Length	Effective Area cm ²	Force to Compress N/mm	Part Number
15	25	200	3	3.9	AX3/015/MSC(25)
20	25	200	6	7.8	AX3/020/MSC(25)
25	25	200	9	12.7	AX3/025/MSC(25)
32	25	210	13	17.2	AX3/032/MSC(25)
40	25	220	20	19.6	AX3/040/MSC(25)
50	25	250	30	19.6	AX3/050/MSC(25)
65	25	273	50	25.0	AX3/065/MSC(25)
15	50	300	3	3.9	AX3/015/MSC(50)
20	50	300	6	7.8	AX3/020/MSC(50)
25	50	300	9	12.7	AX3/025/MSC(50)
32	50	310	13	17.2	AX3/032/MSC(50)
40	50	320	20	19.6	AX3/040/MSC(50)
50	50	350	30	19.6	AX3/050/MSC(50)

The anchor loads generated by using this type of Axial Expansion Compensator are high. It is worth keeping in mind the type of pipework bracketry that will be used. A guide bracket with a low frictional resistance should be used such as DST LF Slide guides or DST Guide Clips.

Please note these units are not suitable for use on a drop rod system and need to be suitably guided. Please consult the Expansion Compensator Application Guide for positioning of anchor points and subsequent support centres. (See Page 116)

Primary Pipe Guide Spacings



DST Group Ltd Reserves the right to alter / amend product data without prior notification

Key Points

Require Full Guiding

Available for any Temperature or Pressure

Supplied with CE Certs where Applicable

Internal Flow Liner as Standard

Bellows are Pre-Cold Drawn



DST Type AX3 (SPE) Axial Bellows

Designed to accept linear expansion on Steel & Copper pipe systems.

Working Conditions

Pressure: Standard 10 Bar (Upto 16 Bar - Dependant on PED Conditions)
Temperature: 120 Degrees C
Test: 1.5x Working

PED Requirements

All Bellows supplied by DST Group Ltd are manufactured and certified in accordance with EU PED Legislation and as such carry the relevant CE certification where required.

Size (mm)	Axial Compression (mm)	Installed Length	Effective Area cm ²	Force to Compress N/mm	Part Number
15	25	200	3.0	3.9	AX3/015/SPE25
18	25	200	3	7.8	AX3/012/SPE(25
22	25	200	6	12.7	AX3/020/SPE25)
28	25	200	9	12.7	AX3/025/SPE(25)
35	25	210	13	17.2	AX3/032/SPE(25)
42	25	220	20	19.6	AX3/040/SPE(25)
54	25	250	30	17.6	AX3/050/SPE(25)

The anchor loads generated by using this type of Axial Expansion Compensator are high. It is worth keeping in mind the type of pipework bracketry that will be used. A guide bracket with a low frictional resistance should be used such as DST LF Slide guides or DST Guide Clips.

Please note these units are not suitable for use on a drop rod system and need to be suitably guided. Please consult the Expansion Compensator Application Guide for positioning of anchor points and subsequent support centres. (See Page 116)

Primary Pipe Guide Spacings

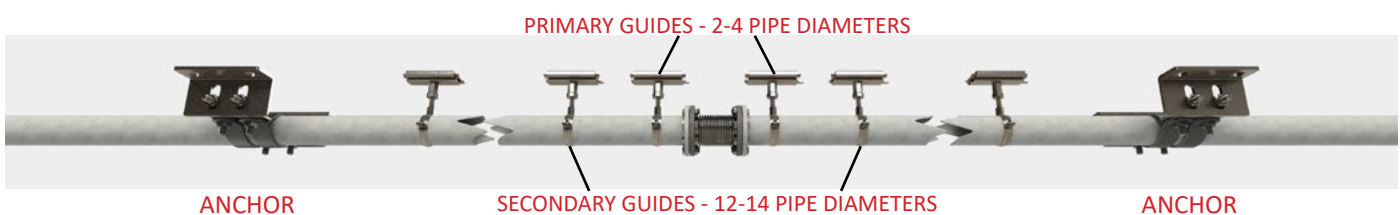

Key Points

FA1 for steel pipes

FA2 for copper & stainless steel

Supplied with CE certs where applicable

Internal flow liner as standard

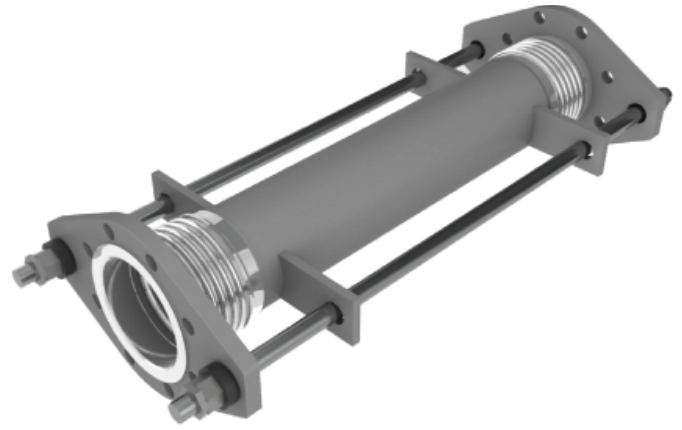

Size	Installed Length +/- 25 (mm)	Force to Deflect +/- 25mm (N/mm)	Installed Length +/- 50 (mm)	Force to Deflect +/- 50 (mm)	Part Number
25	500	10.7	500	2.8	FA1/025/PN16
32	350	10.7	500	2.8	FA1/032/PN16
40	350	10.7	500	2.8	FA1/040/PN16
50	350	12.1	500	4	FA1/050/PN16
65	350	15.9	500	5	FA1/065/PN16
80	350	56.7	500	16	FA1/080/PN16
100	350	94.0	500	27	FA1/100/PN16
125	500	21.6	500	11	FA1/125/PN16
150	500	38.2	650	19	FA1/150/PN16
200	500	29.8	700	17	FA1/200/PN16
250	500	55.2	700	32	FA1/250/PN16

Size	Installed Length +/- 75 (mm)	Force to Deflect +/- 75mm (N/mm)	Installed Length +/- 100 (mm)	Force to Deflect +/- 100 (mm)	Part Number
25	750	1.3	900	1.3	FA1/025/PN16
32	750	1.3	900	1.3	FA1/032/PN16
40	750	1.3	900	1.3	FA1/040/PN16
50	750	1.7	900	1.3	FA1/050/PN16
65	750	2.2	900	1.3	FA1/065/PN16
80	750	7.7	900	2.7	FA1/080/PN16
100	750	12.3	900	5.4	FA1/100/PN16
125	800	4.3	1000	5.4	FA1/125/PN16
150	800	11.1	1000	4.5	FA1/150/PN16
200	900	11.5	1000	4.5	FA1/200/PN16
250	900	22.8	1100	4.5	FA1/250/PN16

Material Specification

Connections:	Carbon Steel Drilled PN1 6 (Van-stone Facings on FA2)
Convolutions:	321 Stainless Steel (316 Stainless steel on FA2)
Internal Sleeve:	321 Stainless Steel (316 Stainless steel on FA2)
Tie Rods:	Carbon Steel
Hemispherical Washers:	Carbon Steel
Connecting Spool:	Carbon Steel (316 Stainless steel on FA2)

The DST Type FA1 & FA2 Lateral Expansion compensator is suitable for use on systems up to 250°C at 16 bar pressure PED certification supplied dependant upon application.

All units are supplied at installation lengths and are pre stressed. Please note DST Group Ltd can design and supply lateral expansion compensators to accommodate higher system temperatures / pressures and other rates of lateral movement or special dimensions. Please advise at time of enquiry / order the system temperature and pressure to allow correct selection of compensator.

Standard Installation

These units are often used when new mains are being connected to existing mains. They allow a lateral movement to occur. These units are also useful for connections from boilers and plant, which will compensate any stresses put onto the "Headers". Advice should always be sought when using these units to ensure the units will allow the amount of movement which will occur. Please consult the Expansion Compensator Application Guide for positioning of the anchor points and subsequent support centres. (See page 116)

Key Points

AN1 for Steel Pipes

AN2 for Copper & Stainless Steel

Supplied with CE Certs where Applicable

Internal Flow Liner as Standard



Size (mm)	Angular Deflection	Installed Length	Effective Area cm ²	Force to Deflect Nm/deg	Part Number
25	+/- 5°	195	40	1.27	AN1/025/PN16
32	+/- 5°	195	40	3.04	AN1/032/PN16
40	+/- 5°	200	40	3.04	AN1/040/PN16
50	+/- 5°	133	40	3.34	AN1/050/PN16
65	+/- 5°	133	62	1.47	AN1/065/PN16
80	+/- 5°	133	81	1.47	AN1/080/PN16
100	+/- 5°	133	127	1.27	AN1/100/PN16
125	+/- 6.5°	199	195	3.04	AN1/125/PN16
150	+/- 6.5°	199	273	3.04	AN1/150/PN16
200	+/- 7.5°	212	469	3.34	AN1/200/PN16
250	+/- 7.5°	212	700	3.04	AN1/250/PN16

Material Specification

Connections:	Carbon Steel Drilled PN16 (Van-stone facings on AN2) Other Flanges Available If Required
Convolutions:	321 Stainless Steel (316 Stainless steel on AN2)
Internal Sleeve:	321 Stainless Steel (316 Stainless steel on AN2)
Hinge Pins:	Carbon Steel

The DST Type AN1 & AN2 Angular Expansion compensators are suitable for use on systems up to 200°C at 16 bar pressure. All units are supplied at installation lengths and are pre stressed. Please note DST Group Ltd can design and supply angular expansion compensators to accommodate higher system temperatures / pressures or special dimensions. Please advise at time of enquiry / order the system temperature and pressure to allow correct selection of compensator.

PED Requirements

CE Certificates issued if required. All units are categorised to PED standards, and we require accurate temperatures and pressures at time of order to enable correct selection and certification.

Standard Installation

These units are commonly used in pairs, although three pin systems can be designed if required. Please contact our sales office for application and design advice. These units can be used on a drop rod system. Please consult the Expansion Compensator Application Guide for positioning of anchor points. (See page 116)

Key Points

G1 for Steel Pipes

G12 for Copper & Stainless Steel

Supplied with CE Certs where Applicable

Internal Flow Liner as Standard



Size (mm)	Angular Deflection	Installed Length	Force to Deflect Nm/deg	Part Number
25	+/- 5°	195	8.3	G11/025/PN16
32	+/- 5°	195	8.3	G11/032/PN16
40	+/- 5°	195	8.3	G11/040/PN16
50	+/- 5°	180	8.3	G11/050/PN16
65	+/- 5°	180	10.1	G11/065/PN16
80	+/- 5°	180	31.4	G11/080/PN16
100	+/- 5°	180	60.8	G11/100/PN16
125	+/- 6.5°	225	36.2	G11/125/PN16
150	+/- 6.5°	225	55.3	G11/150/PN16
200	+/- 7.5°	250	107.1	G11/200/PN16
250	+/- 7.5°	250	192	G11/250/PN16

Material Specification

Connections:	Carbon Steel Drilled PN16 (Van-stone facings on G12) Other Flanges Available If Required
Convolutions:	321 Stainless Steel (316 Stainless steel on G12)
Internal Sleeve:	321 Stainless Steel (316 Stainless steel on G12)
Hinge Pins:	Carbon Steel

The DST Type G11 & G12 Gimbal Expansion compensators are suitable for use on systems up to 200°C at 16 bar pressure. All units are supplied at installation lengths and are pre stressed.

Please note DST Group Ltd can design and supply gimbal expansion compensators to accommodate higher system temperatures / pressures or special dimensions. Please advise at time of enquiry / order the system temperature and pressure to allow correct selection of compensator.

PED Requirements

CE Certificates issued if required. All units are categorised to PED standards, and we require accurate temperatures and pressures at time of order to enable correct selection and certification.

Standard Installation

These units are commonly used in pairs, although three pin systems can be designed if required. Please contact our sales office for application and design advice. These units can be used on a drop rod system. (See page 116)

Key Points



Flanges: Carbon Steel - Drilled PN16 or PN6
(Other Flanges Available)

Nylon Re-inforced EPDM Rubber Body

Steel Reinforced Collars

Round flanges - No Tie Bars

Size (mm)	Installed Length	Material Type	Temperature Limits °C	Part Number
32	130	Nylon Reinforced EPDM	-10 - 90	DST/032/PN16/6
40	130	Nylon Reinforced EPDM	-10 - 90	DST/040/PN16/6
50	130	Nylon Reinforced EPDM	-10 - 90	DST/050/PN16/6
65	130	Nylon Reinforced EPDM	-10 - 90	DST/065/PN16/6
80	130	Nylon Reinforced EPDM	-10 - 90	DST/080/PN16/6
100	130	Nylon Reinforced EPDM	-10 - 90	DST/100/PN16/6
125	130	Nylon Reinforced EPDM	-10 - 90	DST/125/PN16/6
150	130	Nylon Reinforced EPDM	-10 - 90	DST/150/PN16/6

DST D-Flex Pump Flexibles are installed to absorb vibration and noise levels caused by "Plant" upon which they are fitted. These are suitable for use on systems carrying Chilled & Heating Water. Please see above for temperature & Pressure limits.

DST D Flex units are not suitable for use with Potable Water, Water with Oil additives, Compressed Air and Food Applications.

DST D Flex Untied units should not be installed on pumps located on Inertia bases

DST D-Flex units are manufactured from spherical moulded EPDM, which is a soft compound to offer a high isolation efficiency and high noise absorbing properties.

The units are a full bore thus removing pressure drop problems. The EPDM rubber is nylon re-inforced, and has a steel wire re-inforced collar.

Flanges BZP coated carbon steel PN16.

D-Flex units have up to 10 year design life* and are warranted for a period of 12 months** from supply.

DST D Flex units are stamped with Origin of Manufacture, Date Of Manufacture, Batch Number and Size.

Please note no torsion forces should be applied to these units.

DST Group Ltd also Supply DIN 4809 Approved Pump Flexibles. Please Contact our Sales Office for further information.

* Design life is guidance only. This guidance assumes the unit will not be working at the extremes of its working capacity. This in no way implies a warranty or a guarantee.

** 12 Months warranty is against manufacturing defect only and is limited to the supply only of a replacement product of the same type.

Key Points

Flanges: Carbon Steel - Drilled PN16
 (Other Flanges Available)

Nylon Re-inforced EPDM Rubber Body

Steel Reinforced Collars

Tie Bars: Anti-Tamper Carbon Steel



Size (mm)	Installed Length	Material Type	Temperature Limits °C	Part Number
32	130	Nylon Reinforced EPDM	-10 - 90	DST/032/PN16T
40	130	Nylon Reinforced EPDM	-10 - 90	DST/040/PN16T
50	130	Nylon Reinforced EPDM	-10 - 90	DST/050/PN16T
65	130	Nylon Reinforced EPDM	-10 - 90	DST/065/PN16T
80	130	Nylon Reinforced EPDM	-10 - 90	DST/080/PN16T
100	130	Nylon Reinforced EPDM	-10 - 90	DST/100/PN16T
125	130	Nylon Reinforced EPDM	-10 - 90	DST/125/PN16T
150	130	Nylon Reinforced EPDM	-10 - 90	DST/150/PN16T
200	130	Nylon Reinforced EPDM	-10 - 90	DST/200/PN16T
250	130	Nylon Reinforced EPDM	-10 - 90	DST/250/PN16T
300	On Request	Nylon Reinforced EPDM	-10 - 90	DST/300/PN16T
350	On Request	Nylon Reinforced EPDM	-10 - 90	DST/350/PN16T
400	On Request	Nylon Reinforced EPDM	-10 - 90	DST/400/PN16T

DST D-Flex Pump Flexibles are installed to reduce Vibration and noise levels caused by "Plant" upon which they are fitted. These are suitable for use on systems carrying Chilled & Heating Water. Please see above for temperature & Pressure limit. DST D-Flex units are not suitable for use with Potable Water, Water with Oil additives, Compressed Air and Food Applications.

DST D-Flex units are manufactured from spherical moulded EPDM, which is a soft compound to offer a high isolation efficiency and high noise absorbing properties.

The D-flex units tied type has specially designed anti tamper tie bars. This will only allow the units to be installed at their optimal length and avoid elongation of the unit. These units rated to Maximum 10bar working pressure, 15bar test pressure

The units are a full bore thus removing pressure drop problems. The EPDM rubber is nylon re-inforced, and has a steel wire re-inforced collar.

Flanges BZP coated carbon steel PN16.

D-Flex units have up to 10 year design life* and are warrantied for a period of 12** months from supply.

DST D Flex units are stamped with Origin of Manufacture, Date Of Manufacture, Batch Number and Size.

Please note no torsion forces should be applied to these units.

DST Group Ltd also supply DIN 4809 Approved Pump Flexibles. Please contact our sales office for further information.

* Design life is guidance only. This guidance assumes the unit will not be working at the extremes of its working capacity. This in no way implies a warranty or a guarantee.

** 12 Months warranty is against manufacturing defect only and is limited to the supply only of a replacement product of the same type.

Key Points



Unions: Carbon Steel

Nylon Re-inforced EPDM Rubber Body

Steel Reinforced Collars

Size (mm)	Installed Length	Material Type	Temperature Limits °C	Part Number
15	200	Nylon Reinforced EPDM	-10 - 90	PGS/015
20	200	Nylon Reinforced EPDM	-10 - 90	PGS/020
25	200	Nylon Reinforced EPDM	-10 - 90	PGS/025
32	200	Nylon Reinforced EPDM	-10 - 90	PGS/032
40	200	Nylon Reinforced EPDM	-10 - 90	PGS/040
50	200	Nylon Reinforced EPDM	-10 - 90	PGS/050

DST D-Flex Pump Flexibles are installed to absorb vibration and noise levels caused by "Plant" upon which they are fitted. These are suitable for use on systems carrying Chilled & Heating Water. Please see above for temperature & Pressure limits.

DST D Flex units are not suitable for use with Potable Water, Water with Oil additives, Compressed Air and Food Applications.

DST D Flex Untied units should not be installed on pumps located on Inertia bases

DST D-Flex units are manufactured from spherical moulded EPDM, which is a soft compound to offer a high isolation efficiency and high noise absorbing properties.

The units are a full bore thus removing pressure drop problems. The EPDM rubber is nylon re-inforced, and has a steel wire re-inforced collar.

Unions BZP coated carbon steel PN16.

D-Flex units have up to 10 year design life and are warranted for a period of 12 months from supply.

DST D Flex units are stamped with Origin of Manufacture, Date Of Manufacture, Batch Number and Size.

Please note no torsion forces should be applied to these units.

DST Group Ltd also supply DIN 4809 approved pump flexibles. Please contact our sales office for further information.

Flange Suitability:

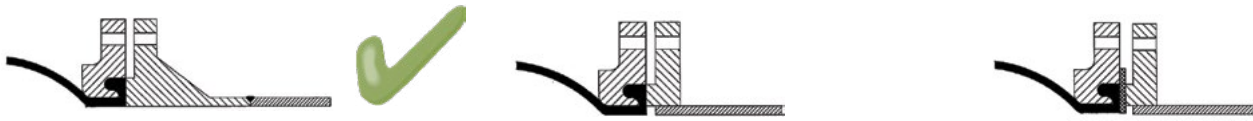

Pre-installation Check

1. Selection

Prior to installation, check you have the right flexibles for the particular duty. All DST D-Flex Rubber Pump Flexibles have temperature and pressure limitations. Please see the appropriate data sheets for your particular product. This is NOT a product for taking up pipework expansion.

All rubber flexibles will extend under pressure. This creates thrust forces which can be very substantial. We recommend at pressures above 2 Bar and diameters above 65mm nominal bore size, unless the pipe work can be sufficiently anchored directly after the unit, the DST D-Flex Anti-Tamper Tied pump flexibles should be used.

2. Mating Flanges

We recommend the rubber flexibles are mated up against full-bore weld neck flanges. If installed in this manner no additional gaskets are required.

We advise against using slip-on or screwed flanges as mating flanges, as these can damage the rubber bellows. Once the sealing face has been damaged, water/medium will penetrate the reinforcement layers and destroy the integrity of the flexibles.

If it is unavoidable to use this type of mating flange, a gasket must be installed (this should be a hard gasket and be at least 3mm thick). The gasket should reach the internal bore of the rubber bellows. Another option is to fill the gap of the slip-on flange with weld and grind it flush. However, the surface finish must be level and smooth to ensure that the bellow is not damaged once installed.

3. Misalignment

Check the two mating flanges are parallel and that they are in line (maximum allowed offset is 5mm in any direction). The gap between flanges should be within +/- 5mm of the flexibles neutral. Compression or extension should be avoided.

Under no circumstances must the pump flexible be used to take up misalignment. Ensure the pipework is adequately supported. The flexible must not support pipes or plant.

Taking Care of Rubber Flexibles:

1. Paint - Do not paint rubber flexibles. The paint will attack the rubber (this also applies to paint splatter).
2. Welding - Protect the rubber from weld spatter.
3. Lagging - Do not lag rubber flexibles on heating systems. The increased temperature will reduce life.
4. Tie Bar Check - Once the system is filled but not under pressure, check the tie bars are still tight (pipe work on springs may have dropped due to the weight of the water).

Note: Tied Pump Flexibles are supplied with anti-tamper tie bars, therefore the Tie bars cannot be slackened off and should not be removed, doing so could lead to, major damage to the unit thus damaging equipment.

5. Water Treatment – The pump flexible range incorporates an EPDM inner liner. EPDM is a proven material in heating and chilled water systems. It is resistant to glycol and to most chemicals used in water treatment, when used in normal concentrations. We cannot approve any specific chemical, and suggest you always check with the chemical supplier that the additives are suitable for use with EPDM rubber. For other mediums check with your local Wolseley Center for suitability.

Best Practice

The following are only recommendations but if followed they will ensure proper installation and maximum service life of the rubber bellows. We recommend the use of spool pieces to align mating flanges and to ensure the correct gap.

1. Pump flexibles should NEVER be used to counter mis-alignment in pipework.

2. Pump flexibles should never be used to support the pipework. Correct guiding and anchoring should be installed close to the pump flexibles.

3. PUMPS - When the pump flexibles are installed on rotating equipment such as pumps to absorb noise and vibration, the first bracket position after the flexibles should be an anchor. This allows the flexibles to absorb vibration but limits their ability to extend under pressure acting as an acoustic break. If pumps are not mounted on springs or inertia bases untied pump flexibles can be used.

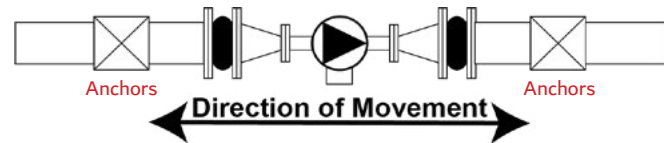

4. INERTIA BASES - Where pumps are installed on inertia bases, Tied Pump Flexibles Should be used. The flexible connection should be directly onto the pump or as near as possible, with anchor points installed after the flexible.

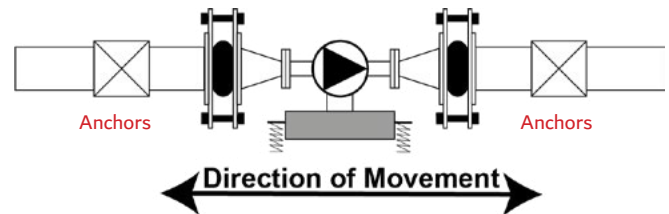

5. IN A RISE - Where pumps are installed on inertia bases, care should be taken NOT to install pump flexibles in vertical pipework on either the return to the pump or flow from the pump. the reasons for this are
 - i. The movement direction changes from axial to lateral.
 - ii. As a result, dependant upon where in the rise the flexibles are, a greater amount of movement can be expressed on the unit laterally, and can be a compound movement with angulation too.
 - iii. Pipe has a greater tendency to use the flexible as a support, as any rigid support would stop the inertia base from working.

In these circumstances neither tied or untied versions are suggested, although, if there is no alternative, a tied unit will offer a better degree of protection.

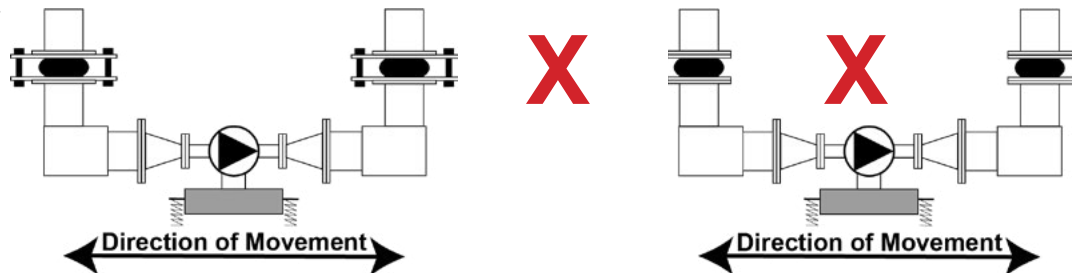

5. PIPE RUNS - Where pump flexibles are being installed to compensate for pipe borne vibration, the flexible still requires anchor on each side to restrict the possibility of extension under pressure. All pipework should be correctly supported between anchors with slide guides to allow movement.

Key Points

Suitable for Potable Water

Suitable for High Temperatures

PED Certified as Required

Stainless Steel to all Wetted Areas

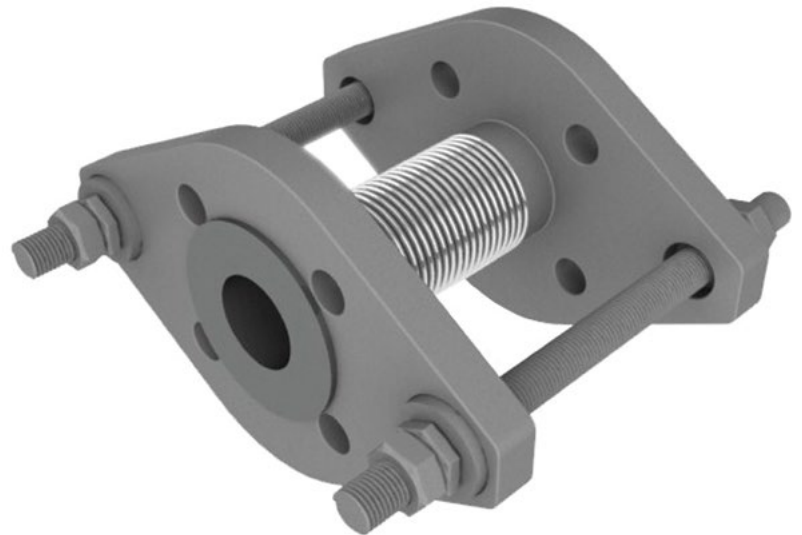

Size (mm)	Installed Length	Material Type	Temperature Limits °C	Part Number
32nb / 35cu	150	316 St/Steel to all Wet Areas	-10 - 200	FA3/032/PN16T
40nb / 42cu	150	316 St/Steel to all Wet Areas	-10 - 200	FA3/040/PN16T
50nb / 54cu	150	316 St/Steel to all Wet Areas	-10 - 200	FA3/050/PN16T
65nb / 67cu	150	316 St/Steel to all Wet Areas	-10 - 200	FA3/065/PN16T
80nb / 76cu	150	316 St/Steel to all Wet Areas	-10 - 200	FA3/080/PN16T
100nb / 108cu	150	316 St/Steel to all Wet Areas	-10 - 200	FA3/100/PN16T
125nb / 133cu	150	316 St/Steel to all Wet Areas	-10 - 200	FA3/125/PN16T
150nb / 159cu	150	316 St/Steel to all Wet Areas	-10 - 200	FA3/150/PN16T
200nb	150	316 St/Steel to all Wet Areas	-10 - 200	FA3/200/PN16T
250nb	On Request	316 St/Steel to all Wet Areas	-10 - 200	FA3/250/PN16T
300nb	On Request	316 St/Steel to all Wet Areas	-10 - 200	FA3/300/PN16T
350nb	On Request	316 St/Steel to all Wet Areas	-10 - 200	FA3/350/PN16T
400nb	On Request	316 St/Steel to all Wet Areas	-10 - 200	FA3/400/PN16T

DST D-Flex Pump Flexibles are installed to reduce Vibration and noise levels caused by “Plant” upon which they are fitted. These are suitable for use on systems carrying high temperature water or potable water systems. Please see above for temperature & Pressure limits. DST FA3 units are suitable for use with Potable Water, Water with Oil additives, Compressed Air and Food Applications.

Material Specification

Connections:	Carbon Steel Drilled PN16 Van-stone Facings
Convolutions:	316 Stainless steel
Internal Sleeve:	316 Stainless steel
Tie Rods:	Carbon Steel
Hemispherical Washers:	Carbon Steel
Connecting Spool:	316 Stainless steel

The DST Type FA3 Pump Flexible is suitable for use on systems up to 200oC at 16 bar pressure. PED certification supplied dependant upon application.

All units are supplied at installation lengths and are pre stressed. Please note, DST Group Ltd can design and supply flexible connections to accommodate higher system temperatures / pressures. Please advise at time of enquiry / order the system temperature and pressure to allow correct selection of compensator.

Key Points



EPDM Rubber Core

304 Stainless Steel Overbraid

Hose WRAS Approved

Manufactured by DST in the UK

0 - 100°C @ 10 Bar

Description -	EPDM Rubber hose with 304 Stainless steel overbraid, swaged fittings to clients requirements.
Testing -	Hydrostatic batch test to minimum 20 bar cold. Test Certificate can be submitted upon request.
Approvals -	All hose is WRAS approved irrespective of application.
Applications -	Fan Coil Connections Radiant Panel Connections Tap Connections
Insulation	Hoses for CHW applications can be insulated with ArmaFlex® Class 0 Nitrile Rubber

Fittings

FIT001
Fixed Taper Male



FIT004
Compression



FIT002
Swivel Flat Face Female



FIT005
Brass Standpipe



FIT006
Flat Face 90° Female Elbow



Key Points

321 Stainless Steel Core

304 Stainless Steel Overbraid

Manufactured in the UK

0 - 100°C @ 10 Bar



Description - 321 Stainless steel hose with 304 Stainless steel overbraid. Welded fittings to client requirements.

Testing - Hydrostatic batch test to minimum 20 bar cold. Test Certificate can be submitted upon request.

Applications -
Fan Coil Connections
Radiant Panel Connections
Tap Connections
Final Connections to Equipment

Fittings

FIT001

Fixed Taper Male



FIT006

Flat Face 90° Female Elbow



FIT002

Swivel Flat Face Female



FIT007

Coned Face 90° Female Elbow



FIT003

Swivel Coned Seat Female



Key Points

10 Year Guarantee for EPDM. 2 Year Guarantee for Stainless Steel

25 Year Design Life

ISO9001 Quality System

Manufactured at DSTGroup Ltd in the UK



Installation

Installation conditions as below must be adhered to, to ensure longevity of the product.



Slack is present on straight lengths & ends are aligned

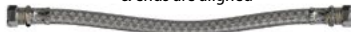

Avoid bending radius becoming too small by using elbows



Hose is long enough to allow smooth curve



Do not bend hose too close to crimped end



Observe minimum bend radius

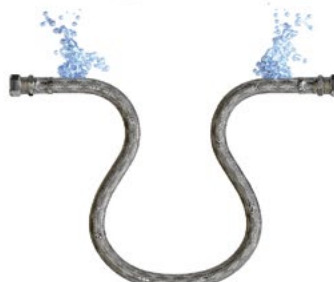

DST Group Ltd Reserves the right to alter / amend product data without prior notification

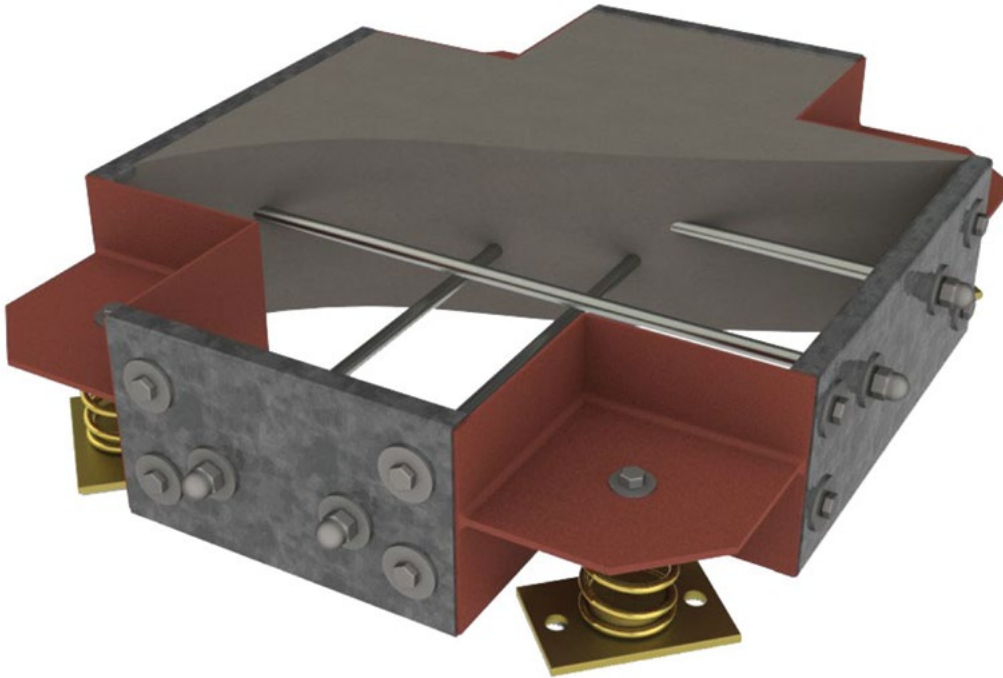

DST Group Ltd Inertia Bases are supplied in a flat pack form to allow ease of installation on site, but can be delivered assembled if required. These are supplied with spring mounts and all fixings required to assemble the inertia base.

DST Group Ltd can calculate the size of inertia base required. Please forward the pump details to DST Group Ltd Sales Office. As standard the DST Ltd Group Inertia Bases are supplied either 150mm or 300mm deep.

DST Group Ltd Inertia Bases are supplied to provide no less than 1.5 : 1.0 Rate of inertia. As standard these bases are supplied with Springs.

DST Group Ltd can, if required supply these bases fully assembled and cast with a 24N mix of concrete.

DST Group Ltd advise that DST/***/PN16T Tied DST D-Flex Pump Flexibles are used for isolating vibration from pump connections.

Please Note:

Spring selection should be based upon equipment weight - DST Group Ltd can advise on selection at time of ordering.

Plant and pipework can be loaded unevenly, therefore different spring loads maybe required at different locations - Again DST Group Ltd can advise on selection at time of ordering.

Standard springs and housings are BZP with yellow passivate, othercoatings can be offered for external use. Please advise if your application is external.

Springs when fitted should be loaded equally, installing one spring before another will lead to uneven load.

Key Points



Anti-Vibration Mount for Plant & Machinery

Enclosed Spring for Greater Stability.

Standard 25mm Deflection

Can be used in Conjunction with Inertia Bases

Model	Overall Width (mm)	Bolt Centres (mm)	Bolt Ø	Fixing Bolt Ø	Weight Range (Kg)	Deflection (mm)
DS/0-0050	130	110	M10	M12	11-23	25
DS/0-0080	130	110	M10	M12	18-37	25
DS/0-0130	130	110	M10	M12	30-60	25
DS/0-0200	130	110	M10	M12	45-91	25
DS/0-0300	130	110	M10	M12	68-137	25
DS/0-0500	130	110	M10	M12	114-228	25
DS/0-0630	130	110	M10	M12	148-296	25
DS/0-0800	130	110	M10	M12	182-364	25
DS/1-0150	173	148	M12	M12	34-69	25
DS/1-0200	173	148	M12	M12	45-91	25
DS/1-0300	173	148	M12	M12	68-137	25
DS/1-0500	173	148	M12	M12	114-228	25
DS/1-0750	173	148	M12	M12	170-341	25
DS/1-1000	173	148	M12	M12	227-455	25
DS/1-1200	173	148	M12	M12	273-546	25
DS/1-1400	173	148	M12	M12	318-637	25
DS/1-2-1700	173	148	M12	M12	386-773	25
DS/1-2-1900	173	148	M12	M12	432-864	25

Please Note

Spring selection should be based upon equipment weight - DST Group Ltd can advise on selection at time of ordering.

Plant and pipework can be loaded unevenly, therefore different spring loads maybe required at different locations - DST Group Ltd can advise on selection at time of ordering.

Standard housing is powder coated, the standard spring is BZP, other coatings can be offered for external use. Please advise if your application is external.

Springs when fitted should be loaded equally, installing one spring before another will lead to uneven load.

Key Points

2 Year Guarantee

25 Year Design Life

ISO9001 Quality System

Manufactured in the UK

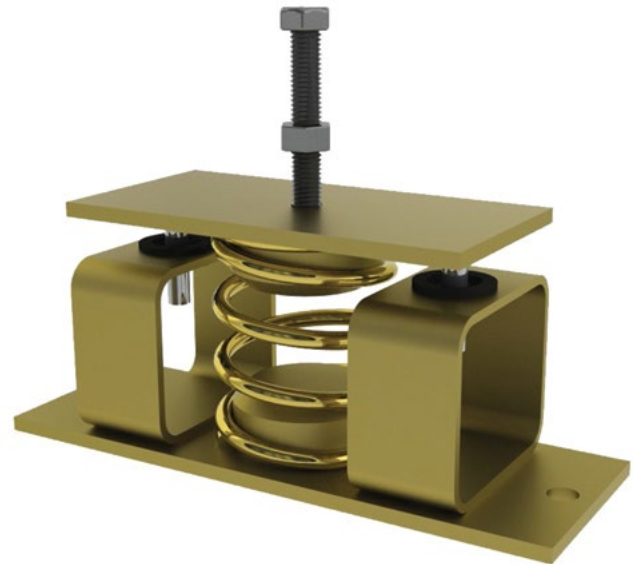

Model	Overall Width (mm)	Bolt Centres (mm)	Bolt Ø	Fixing Bolt Ø	Weight Range (Kg)	Deflection (mm)
RS/0-0050	230	198	M12	M12	11-23	30
RS/0-0080	230	198	M12	M12	18-37	30
RS/0-0130	230	198	M12	M12	30-60	30
RS/0-0200	230	198	M12	M12	45-91	30
RS/0-0300	230	198	M12	M12	68-137	30
RS/0-0500	230	198	M12	M12	114-228	30
RS/0-0630	230	198	M12	M12	148-287	30
RS/0-0800	230	198	M12	M12	182-364	30
RS/0-1100	230	198	M12	M12	250-500	30
RS/1-0425	230	198	M12	M12	97-194	30
RS/1-0600	230	198	M12	M12	136-273	30
RS/1-0750	230	198	M12	M12	170-341	30
RS/1-1000	230	198	M12	M12	227-455	30
RS/1-1400	230	198	M12	M12	318-637	30
RS/1-1700	230	198	M12	M12	386-773	30
RS/1-2000	230	198	M12	M12	455-910	30
RS/1-2400	230	198	M12	M12	545-1091	30

Please Note:

Spring selection should be based upon equipment weight - DST Group Ltd can advise on selection at time of ordering.

Plant and pipework can be loaded unevenly, therefore different spring loads maybe required at different locations - DST Group Ltd can advise on selection at time of ordering.

Standard springs and housings are BZP with yellow passivate, other coatings can be offered for external use. Please advise if your application is external.

Springs when fitted should be loaded equally, installing one spring before another will lead to uneven load.

Key Points

2 Year Guarantee

25 Year Design Life

ISO9001 Quality System

Manufactured in the UK

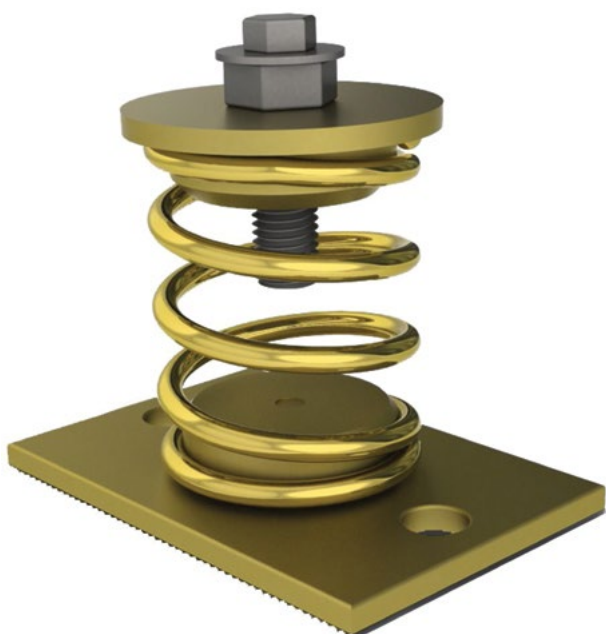

Model	Overall Width (mm)	Bolt Centres (mm)	Bolt Ø	Fixing Bolt Ø	Weight Range (Kg)	Deflection (mm)
OS/0-0050	130	92	M12	M10	11-23	30
OS/0-0080	130	92	M12	M10	18-37	30
OS/0-0130	130	92	M12	M10	30-60	30
OS/0-0200	130	92	M12	M10	45-91	30
OS/0-0300	130	92	M12	M10	68-137	30
OS/0-0500	130	92	M12	M10	114-228	30
OS/0-0630	130	92	M12	M10	148-287	30
OS/0-0800	130	92	M12	M10	182-364	30
OS/0-1100	130	92	M12	M10	250-500	30
OS/1-0425	165	120	M12	M12	97-194	30
OS/1-0600	165	120	M12	M12	136-273	30
OS/1-0750	165	120	M12	M12	170-341	30
OS/1-1000	165	120	M12	M12	227-455	30
OS/1-1400	165	120	M12	M12	318-637	30
OS/1-1700	165	120	M12	M12	386-773	30
OS/1-2000	165	120	M12	M12	455-910	30
OS/1-2400	165	120	M12	M12	545-1091	30

Please Note:

Spring selection should be based upon equipment weight - DST Group Ltd can advise on selection at time of ordering.

Plant and pipework can be loaded unevenly, therefore different spring loads maybe required at different locations - DST Group Ltd can advise on selection at time of ordering.

Standard springs and housings are BZP with yellow passivate, other coatings can be offered for external use. Please advise if your application is external.

Springs when fitted should be loaded equally, installing one spring before another will lead to uneven load.

Key Points

Suitable for isolating vibration from packaged units

Pressurisation Units

Please advise the weight and plant footprint requiring isolation for mount recommendations



Weight (Kg)	Material Type	Hole Tapping Size	Dimensions (mm) Width x Height	Part Number
150	Neoprene Commercial Grade Black Rubber	M10	75 x 32	CMC/150/M
300	Neoprene Commercial Grade Black Rubber	M12	90 x 40	CMC/300/M

Key Points

Isolating vibration from Pipework

Please advise the weight of plant requiring isolation for hanger recommendations



Weight (Kg)	Material Type	Hole Tapping Size	Dimensions (mm) Width x Height	Part Number
150	Neoprene Commercial Grade Black Rubber	M10	75 x 32	CMC/150/M
300	Neoprene Commercial Grade Black Rubber	M12	90 x 40	CMC/300/M

Please Note:

Mount selection should be based upon equipment weight - DST Group Ltd can advise on selection at time of ordering.

Plant and pipework can be loaded unevenly, therefore different mount loads maybe required at different locations - Again DST Group Ltd can advise on selection at time of ordering.

Mounts when fitted should be loaded equally, installing one mount before another will lead to uneven load.

Key Points

2 Year Guarantee

25 Year Design Life

ISO9001 Quality System

Manufactured in the UK



Model	Overall Width (mm)	Bolt Centres (mm)	Bolt Ø	Fixing Bolt Ø	Weight Range (Kg)	Deflection (mm)
SHO S/0-0050	150	180	M12	M12	11-23	30
SHO S/0-0080	150	180	M12	M12	18-37	30
SHO S/0-0130	150	180	M12	M12	30-60	30
SHO S/0-0200	150	180	M12	M12	45-91	30
SHO S/0-0300	150	180	M12	M12	68-137	30
SHO S/0-0500	150	180	M12	M12	114-228	30
SHO S/0-0630	150	180	M12	M12	148-287	30
SHO S/0-0800	150	180	M12	M12	182-364	30
SHO S/0-1100	150	180	M12	M12	250-500	30
SHO S/1-0425	250	250	M16	M16	97-194	30
SHO S/1-0600	250	250	M16	M16	136-273	30
SHO S/1-0750	250	250	M16	M16	170-341	30
SHO S/1-1000	250	250	M16	M16	227-455	30
SHO S/1-1400	250	250	M16	M16	318-637	30
SHO S/1-1700	250	250	M16	M16	386-773	30
SHO S/1-2000	250	250	M16	M16	455-910	30
SHO S/1-2400	250	250	M16	M16	545-1091	30

Please Note:

Spring selection should be based upon equipment weight - DST Group Ltd can advise on selection at time of ordering.

Plant and pipework can be loaded unevenly, therefore different spring loads maybe required at different locations - DST Group Ltd can advise on selection at time of ordering.

Standard springs and housings are BZP with yellow passivate, other coatings can be offered for external use. Please advise if your application is external.

Springs when fitted should be loaded equally, installing one spring before another will lead to uneven load.

Key Points

2 Year Guarantee

25 Year Design Life

ISO9001 Quality System

Manufactured in the UK



Model	Overall Width (mm)	Bolt Centres (mm)	Bolt Ø	Fixing Bolt Ø	Weight Range (Kg)	Deflection (mm)
SHOS/0/P-0050	150	180	M12	M12	11-23	30
SHOS/0/P-0080	150	180	M12	M12	18-37	30
SHOS/0/P-0130	150	180	M12	M12	30-60	30
SHOS/0/P-0200	150	180	M12	M12	45-91	30
SHOS/0/P-0300	150	180	M12	M12	68-137	30
SHOS/0/P-0500	150	180	M12	M12	114-228	30
SHOS/0/P-0630	150	180	M12	M12	148-287	30
SHOS/0/P-0800	150	180	M12	M12	182-364	30
SHOS/0/P-0110	150	180	M12	M12	250-500	30
SHOS/1/P-0425	250	250	M16	M16	97-194	30
SHOS/0/P-0600	250	250	M16	M16	136-273	30
SHOS/1/P-0750	250	250	M16	M16	170-341	30
SHOS/1/P-1000	250	250	M16	M16	227-455	30
SHOS/1/P-1400	250	250	M16	M16	318-637	30
SHOS/1/P-1700	250	250	M16	M16	386-773	30
SHOS/1/P-2000	250	250	M16	M16	455-910	30
SHOS/1/P-2400	250	250	M16	M16	545-1091	30

Please Note:

Spring selection should be based upon equipment weight - DST Group Ltd can advise on selection at time of ordering.

Plant and pipework can be loaded unevenly, therefore different spring loads maybe required at different locations - DST Group Ltd can advise on selection at time of ordering.

Standard springs and housings are BZP with yellow passivate, other coatings can be offered for external use. Please advise if your application is external.

Springs when fitted should be loaded equally, installing one spring before another will lead to uneven load.

Key Points

Microbubble Type

Flanged PN16

10 Bar Working Pressure

110 Degrees C



For use in sealed heating and cooling systems. Air and Dirt Separators protect against damage caused by the deposit of dirt particles, and large amounts of dissolved and undissolved air.

Reduction in:

- Corrosion of pipe and fittings.
- Dependence on chemicals.
- Unwanted dirt build up in equipment & pipe

Whilst increasing efficiency of:

- Boilers & Heat Exchangers.
- Chillers
- Pumps

Air and dirt separators are essential when refurbishing older systems or when an open system is converted to a closed system.

- Flanged connection EN 1092-1 PN16.
- Flow Rate up to 1.5 m/s.

Pipe Size	Face to Face L	Body Diameter D	Height H	Flange	Flow Rate @ 1.5m/s
50mm	430mm	168mm	589mm	PN16	12m ³ /h
65mm	430mm	168mm	589mm	PN16	20m ³ /h
80mm	490mm	220mm	780mm	PN16	28m ³ /h
100mm	490mm	220mm	780mm	PN16	47m ³ /h
125mm	630mm	325mm	952mm	PN16	70m ³ /h
150mm	630mm	325mm	952mm	PN16	100m ³ /h
200mm	810mm	410mm	1266mm	PN16	175m ³ /h

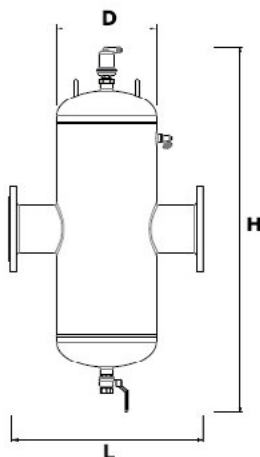

Pressure Drop Chart

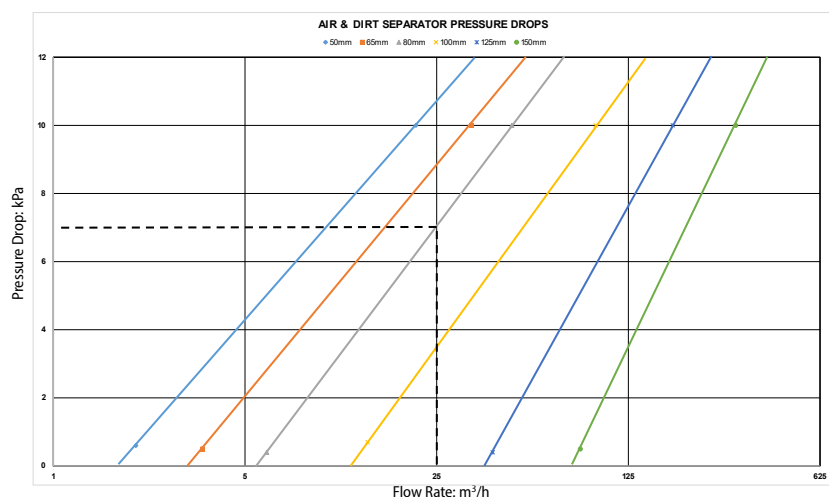

DST Group Ltd Reserves the right to alter / amend product data without prior notification

RapidVent Air & Dirt Separators

Selection & Location

1. Micro Bubbles are easily released from circulating water where the highest temperature and lowest pressure conditions occur in the system
2. The separators should normally be fitted where water is at the highest temperature and the lowest pressure available.
3. When selecting the position for the separator please be aware that pressure also has a major effect on the release of microbubbles.
5. Where lower temperatures are involved in cooling applications system pressure becomes the determining factor of the position of the separator.
7. Rapidvent air and dirt separators should be installed in horizontal pipework, the direction of flow is optional.
8. The static head must not exceed 15m for a heating system and 5m for a cooling / Chilled Water system.
9. The efficiency of the unit will be reduced if the system static head exceeds those indicated or system or flow velocity exceeds 1.5m/s.

Installation (To Be Performed by Qualified Personnel)

1. Protect the Rapidvent air & dirt separator from adverse environmental conditions, protect from frost.
2. This equipment will form part of the main system's maintenance regime, do not obstruct access.
3. The main system must be flushed before installation of the air & dirt separator.
4. Jet Air & Dirt separators are not directional.
5. The equipment must be installed vertically with isolation valves on the inlet and outlet connections to facilitate maintenance inspection and facilitate the venting of separated dirt.
6. To provide the best protection for your system typically this equipment is installed on the hottest side of the heat exchanger, on the suction side of the circulation pump. Please refer to section "Location" for more details.
7. For service purposes it is essential to have 100 mm access clearance above the air vent when installed.
8. When installing, please take into account the weight of the unit, and use the correct equipment for lifting and fitting. Lifting eyes are provided on 150mm and above.
9. Loose accessories should be fitted to unit using Loctite 577 or suitable threadlocking methods:
10. Ensure that the vent cap on the Air Vent is open when commissioning this equipment.
11. Flexible or fixed pipework should be installed to enable dirty water to be drained to a convenient safe place.

Maintenance (To Be Performed by Qualified Personnel)

1. It is recommended that the Rapidvent air & dirt separator should be inspected and drained of dirt after 3 months, then annually thereafter.
2. Should particulate debris build up within the air vent valve, and induce a leak, this can be isolated using the vent cap until such time as appropriate maintenance can take place.
3. Before draining the particulate debris first isolate the Rapidvent air & dirt separator from the main system.
4. Where temperatures are likely to cause harm, please allow the unit to cool before discharging the debris.
5. Open the drain valve to release the accumulated debris from the equipment.
7. Once complete, close the drain valve and reintroduce the Air & Dirt Separator to the main system by opening the isolation valves.
8. Never use the drain valve or air vent to reintroduce water to the system.

WARNING: Any and all maintenance must only take place with the equipment isolated from the main system and when the temperature of the unit and fluid is within safe limits.

Key Points

304 Stainless Steel Construction

Supplied With Tundish & All Valves

Polished Stainless Steel Finish

Wall Mounting Brackets Fitted



Dosing pots are generally installed in closed systems to enable water treatments and other chemicals to be added to the system without the need to shut a system down or part thereof.

The Chempot is a high quality stainless steel vessel which is fatigue resistant as a result of its design. The unit is supplied with all components loose so connections can be fitted in an orientation best suited to the system.

Chempot is fully compliant with the latest BSRIA BG50/2021 recommendations regarding avoiding dead legs and is compliant with Equipment Directive 2014/68/EU Cat SEP and Pressure Equipment (Safety) Regulations 2016.

Sizing:

The size of dosing pot installed in a system is not critical as multiple doses of chemicals can be put in to the system to reach the correct concentration.

The benefits of using a smaller unit, is that it is easier to physically handle and also allows for more accurate dosing. However, the time on site for performing multiple doses has to be considered. This factor should influence your decision when selecting dosing pots.

BSRIA Compliant if installed in this configuration

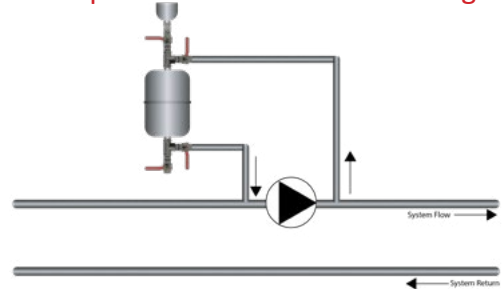

Not BSRIA Compliant if installed in this configuration - But Acceptable

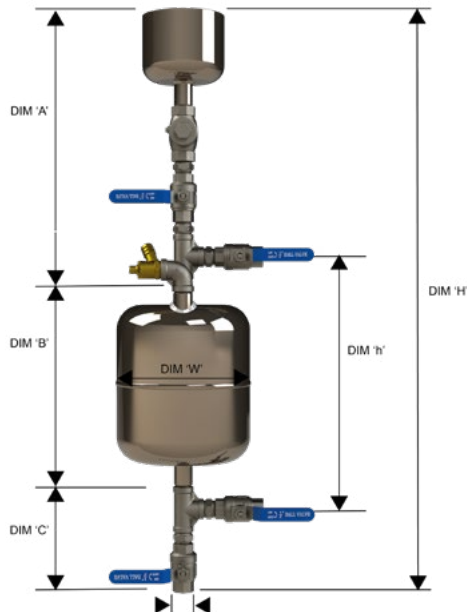
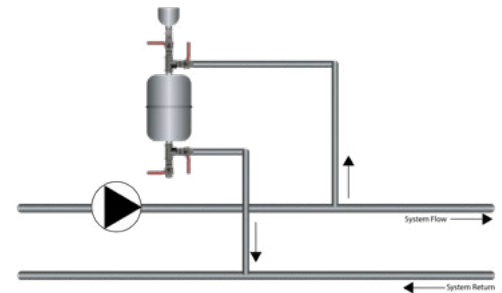

SIZE	Con Size	DIM A	DIM B	DIM C	DIM W	DIM H	DIM h	Working Pressure
3.5L	1/2"	285mm	260mm	130mm	162mm	675mm	310mm	10Bar
6L	1/2"	285mm	260mm	130mm	215mm	675mm	310mm	10Bar
11L	1/2"	285mm	410mm	130mm	215mm	825mm	460mm	10Bar
18L	1/2"	285mm	460mm	130mm	260mm	875mm	510mm	7Bar
25L	1/2"	285mm	590mm	130mm	260mm	1005mm	640mm	7Bar

This guide is designed to offer the engineer the opportunity to make informed selections of methods to compensate for, and adequately support / anchor, pipework subjected to thermal expansion.

This guide and information contained is in no way guaranteed or warranted.

DST Group Ltd will happily offer design and calculation services on a project specific basis, which would be guaranteed and warranted if necessary.

DST Group Ltd accepts no liability in respect of the use of this guide.



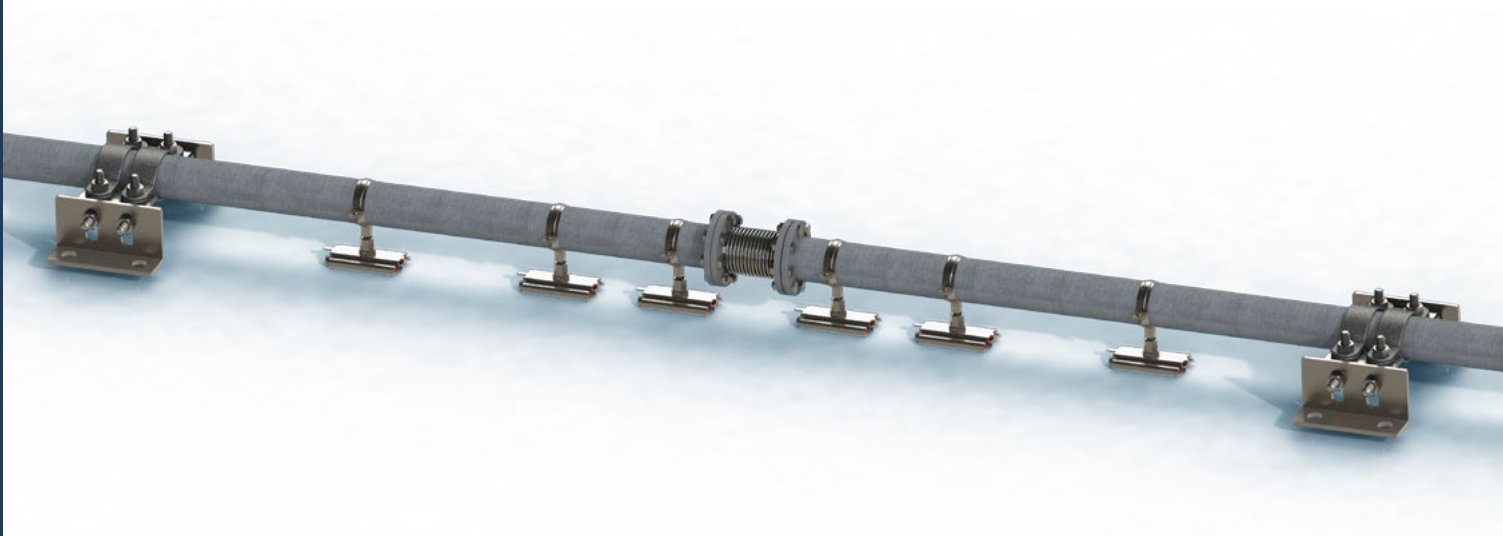

It is an accepted rule of physics that a material, when subjected to a change of temperature, will expand or contract directly related to the temperature. Pipework is therefore subject to the same principal.

Factors to be considered when calculating the amount of expansion are as follows:

1. The amount of temperature change – based upon the lowest ambient temperature.
2. The overall length of pipe upon which calculations are to be based.
3. The co-efficient of expansion for the required material.

Carbon Steel Pipes

The co-efficient of expansion for carbon steel is:
 (These Co-efficients can be used for standard stainless steels)

0 - 100°C = CofΔ 1.11
 101°C + = CofΔ 1.21

Copper Pipes

Copper expands at a 50% higher rate, the equation would be:
 (These Co-efficients can be used for thin wall stainless steels)

0 - 100°C = CofΔ 1.11 x 1.5
 101°C + = CofΔ 1.21 x 1.5

Plastic Pipes

The rate of expansion for plastics differs between materials and manufacturers; it is always advisable to check the rate of thermal expansion with the manufacturer.

The following table shows the expansion ratio in mm/m. This can be used instead of calculating individual sections of pipe.

Expansion Ratio of Pipe				
Steam or Water Temperature		Expansion in mm/m		
°C	°F	Steel Pipes	Copper Pipes	
0	0	0	0	
65	149	0.72	1.08	
82	180	0.91	1.37	
120	248	1.45	2.18	
134	272	1.62	2.43	
144	290	1.74	2.61	
152	305	1.83	2.76	
170	338	2.05	3.09	
184	363	2.23	3.34	
198	388	2.39	n/a	
205	405	2.48	n/a	
217	422	2.62	n/a	
226	439	2.73	n/a	

By using the table above we can extract the movement ratio in mm/m and multiply by the total length of pipe-work:

Example 1

To calculate the expansion on a 75m length of carbon steel pipe passing 10bar steam:

Temperature Rise = 184°C
 Expansion in mm/m = 2.23mm/m
 Pipe Length = 75m
 Total Expansion = 75 x 2.23 = 167.5mmΔ

Example 2

To calculate the expansion on a 25m length of copper pipe supplying LTHW at 82°C:

Temperature Rise = 82°C
 Expansion in mm/m = 1.37mm/m
 Pipe Length = 25m
 Total Expansion = 25 x 1.37 = 34.25mmΔ

Pipework systems have various changes in direction within itself. As this occurs pipework systems should have some natural flexibility within it. The following pages will help the engineer use the changes in direction to naturally flex the expansion that will occur.

Expansion within hot pipework is always present. Expansion rates of 74.4mm over a length of 30mtrs steel pipe-work carrying steam at 205°C needs channelling somewhere.

Items which need to be addressed by the engineer:

- A. Method of pipework bracketing to allow natural flexibility to occur.
- B. Pipework material
- C. Pipework nominal size.
- D. Location and layout of pipework including length.
- E. Minimum and maximum temperature of pipework, media and ambient. Applicable to ambient temperatures 0°C and under.
- F. Working and test pressure of pipework media
- G. Connection points to plant etc.
- H. Structure of building.

Once we have addressed all these items then we can look at solutions.

To help take into account the above items, the engineer should use pipework anchors. Pipework anchors can separate large complicated pipework systems into smaller more manageable systems.

Positioning the anchors so an offset occurs between the anchors could naturally compensate the expansion.

The forces imposed upon an anchor is primarily made up from two areas:

- A. Force to Deflect pipework offset.
- B. Frictional force due to pipework bracketry.

Forces subjected onto the anchor positions can be calculated using the following formulae:-

$$F = \frac{24IX}{L^3} \quad \text{For carbon steel pipes.}$$

$$F = \frac{8.4IX}{L^3} \quad \text{For copper pipes.}$$

F = Force in Newtons

I = Moment of Inertia in cm⁴ Applicable to pipework size (See Page 113)

X = Expansion in mm

L = Length of offset in metres (shortest length)

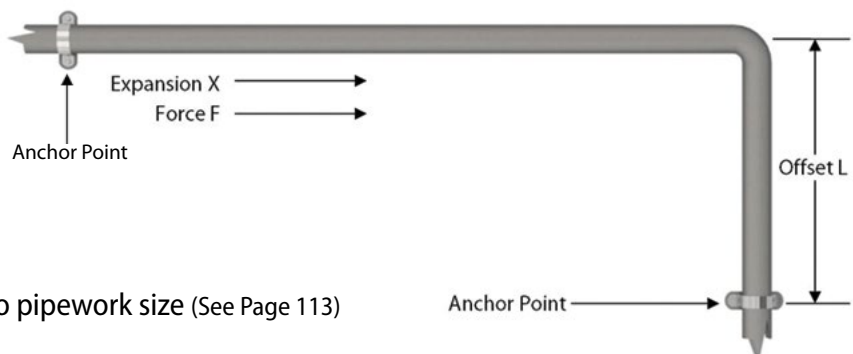

You will also need to add to this result the force is encountered via frictional resistance of pipework bracketry on the pipework.

Examples of frictional resistance can be calculated using the following formulae:-

$$F = L \times 15 \times \frac{I/D}{25}$$

F = Force in Newtons

L = Length of pipework (longest length)

15 = 15 Newtons which is the frictional resistance based on the use of a DST-253 Slide Guide

I/D = Inside diameter of the pipework

Example 1

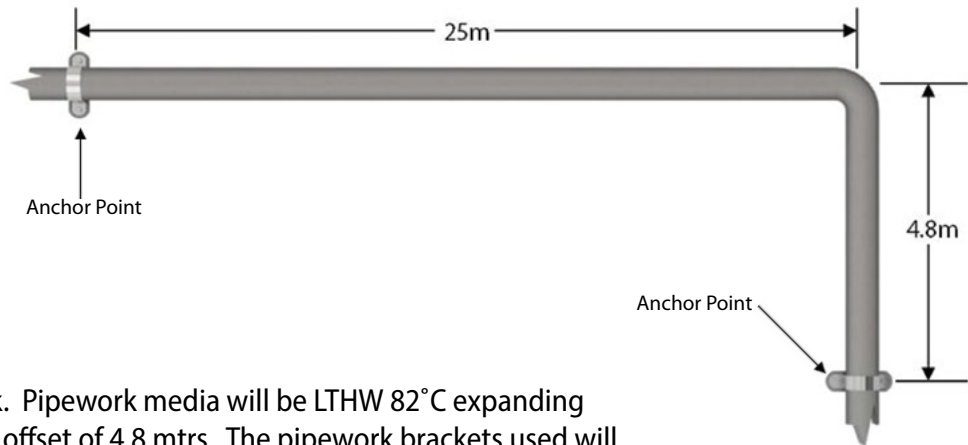

25 mtrs 65NB Steel Pipework. Pipework media will be LTHW 82°C expanding (0.91 x 25) 22.75mm with an offset of 4.8 mtrs. The pipework brackets used will be DST 253 Slide Guides.

$$(A) \quad F = \frac{24IX}{L^3} \quad F = \frac{24 \times 54.5 \times 22.75}{112.68} = 264.08 \text{ Newtons}$$

(B) We also need to add the force to overcome frictional resistance:

$$F = L \times 15 \times I/D \quad F = \frac{25 \times 15 \times 65}{25} = 937.5 \text{ Newtons}$$

Therefore the total anchor load will be:

$$(A) = 264.08 + (B) = 937.50 = 1201.58 \text{ Newtons}$$

Example 2

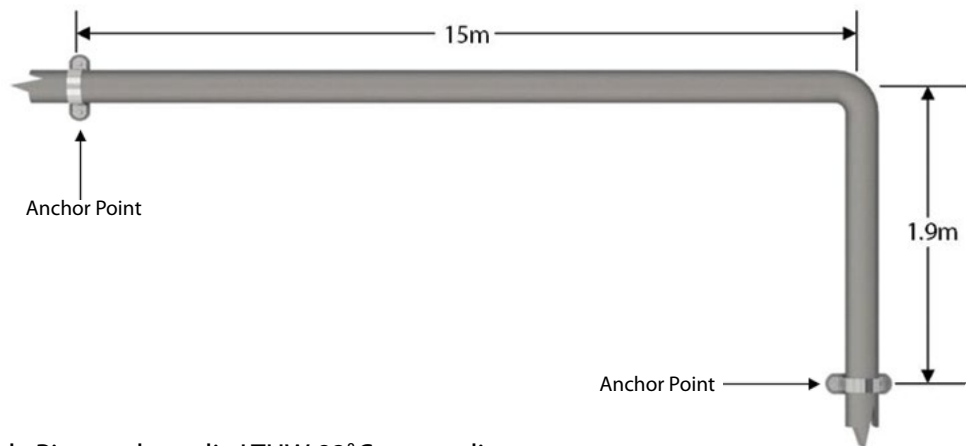

42cu (table Y) copper pipework. Pipework media LTHW 82°C. expanding (1.37 x 15) = 20.55mm The pipework brackets used will be DST Group Ltd Surefix UL pipe clip + DST Ballhanger.

$$(A) \quad F = \frac{8.4IX}{L^3} \quad F = \frac{8.4 \times 3.93 \times 20.55}{6.86} = 98.89 \text{ Newtons}$$

(B) We also need to add the force to overcome frictional resistance.

$$F = L \times 30 \times I/D \quad F = \frac{15 \times 30 \times 42}{25} = 675.00 \text{ Newtons}$$

Therefore the total anchor load will be:

$$(A)=98.89 + (B) = 675.00 = 773.89 \text{ Newtons}$$

If natural offsets occur within the design of the pipework system, it may be possible to utilise this to take up thermal expansion by using the natural flexibility of the pipework. The tables below show the minimum length of offset required for steel and copper pipes subjected to thermal expansion.

A system utilising an offset to take up expansion can be bracketed utilising most common types of brackets including drop rods, sliding and rolling supports. For more information, please see the first section of this product guide for more details.

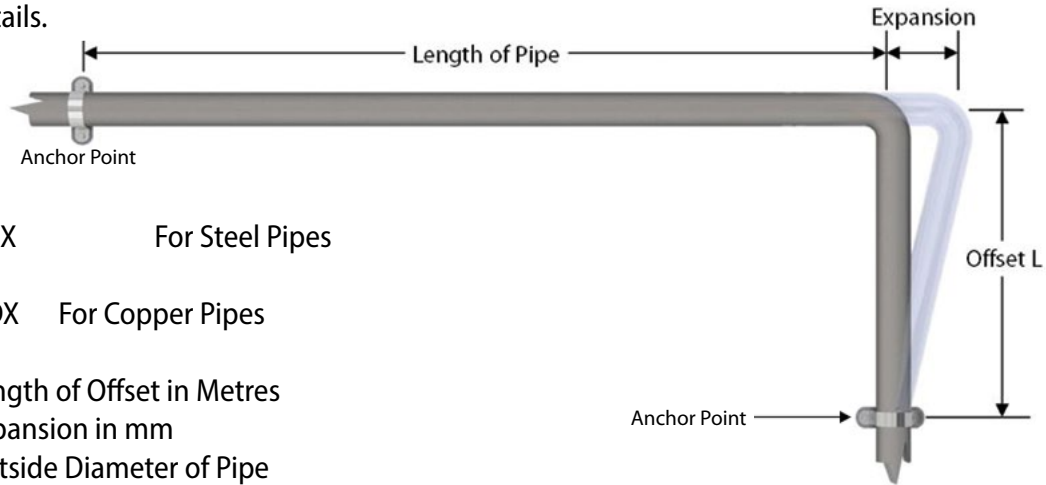

Offset L = 0.1 \sqrt{DX} For Steel Pipes

Offset L = 0.06 \sqrt{DX} For Copper Pipes

- L = Length of Offset in Metres
- X = Expansion in mm
- D = Outside Diameter of Pipe

Table Showing Single Offset For Steel Pipes (Without cold draw)

Expansion X	Pipe Nominal Bore											
	15nb	20nb	25nb	32nb	40nb	50nb	65nb	80nb	100nb	125nb	150nb	200nb
1mm	0.46	0.52	0.58	0.65	0.69	0.77	0.87	0.94	1.09	1.18	1.29	1.48
3mm	0.79	0.90	1.01	1.12	1.20	1.34	1.51	1.63	1.84	2.05	2.24	2.57
5mm	1.02	1.16	1.30	1.45	1.55	1.73	1.95	2.11	2.39	2.65	2.89	3.32
10mm	1.45	1.64	1.84	2.04	2.19	2.44	2.75	2.98	3.38	3.74	4.09	4.69
15mm	1.77	2.01	2.25	2.51	2.68	3.00	3.38	3.65	4.13	4.58	5.01	5.74
20mm	2.05	2.32	2.61	2.89	3.09	3.46	3.89	4.22	4.77	5.90	5.79	6.63
30mm	2.51	2.84	3.19	3.54	3.79	4.24	4.77	5.16	5.85	6.48	7.09	8.12
40mm	2.89	3.29	3.69	4.09	4.38	4.89	5.51	5.97	6.75	7.48	8.19	9.38
60mm	3.55	4.02	4.02	5.01	5.36	6.00	6.75	7.31	8.27	9.17	10.04	11.49
80mm	4.09	4.65	4.65	5.79	6.19	6.92	7.79	8.43	9.54	10.58	11.59	13.27
100mm	4.58	5.19	5.19	6.48	6.92	7.75	8.71	9.43	10.67	11.83	12.96	14.83

Table Showing Single Offset For Copper Pipes (Without cold draw)

Expansion X	Pipe Nominal Bore											
	15nb	22nb	28nb	35nb	42nb	54nb	67nb	76nb	108nb	133nb	159nb	219nb
1mm	0.23	0.28	0.32	0.35	0.39	0.44	0.49	0.52	0.62	0.69	0.76	0.89
3mm	0.40	0.49	0.55	0.61	0.67	0.76	0.85	0.91	1.08	1.19	1.31	1.54
5mm	0.52	0.63	0.71	0.79	0.87	0.99	1.09	1.17	1.39	1.55	1.69	1.99
10mm	0.73	0.89	1.00	1.12	1.22	1.39	1.55	1.65	1.97	2.19	2.39	2.81
15mm	0.90	1.09	1.23	1.37	1.52	1.71	1.90	2.02	2.41	2.68	2.93	3.44
20mm	1.03	1.26	1.42	1.59	1.74	1.97	2.19	2.34	2.78	3.09	3.38	3.97
30mm	1.28	1.54	1.74	1.94	2.12	2.41	2.69	2.86	3.42	3.79	4.14	4.86
40mm	1.47	1.78	2.01	2.24	2.45	2.79	3.11	3.31	3.98	4.38	4.78	5.62
60mm	1.80	2.18	2.46	2.75	3.01	3.42	3.80	4.05	4.83	5.36	5.86	6.88
80mm	2.07	2.52	2.84	3.17	3.48	3.94	4.39	4.68	5.58	6.19	6.77	7.94
100mm	2.32	2.81	3.17	3.55	3.89	4.41	4.91	5.23	6.24	6.92	7.56	8.88

Example of how cold draw can be used:

30m of 100NB Steel Pipework

82°C LTHW

$\Delta = L \times T \times C \text{ of } \Delta$

$$\Delta = 30 \times 82 \times 1.11 = 27.3\text{mm } \Delta$$

27.3mm will require a 5.85m Offset (According to the table on the previous page)

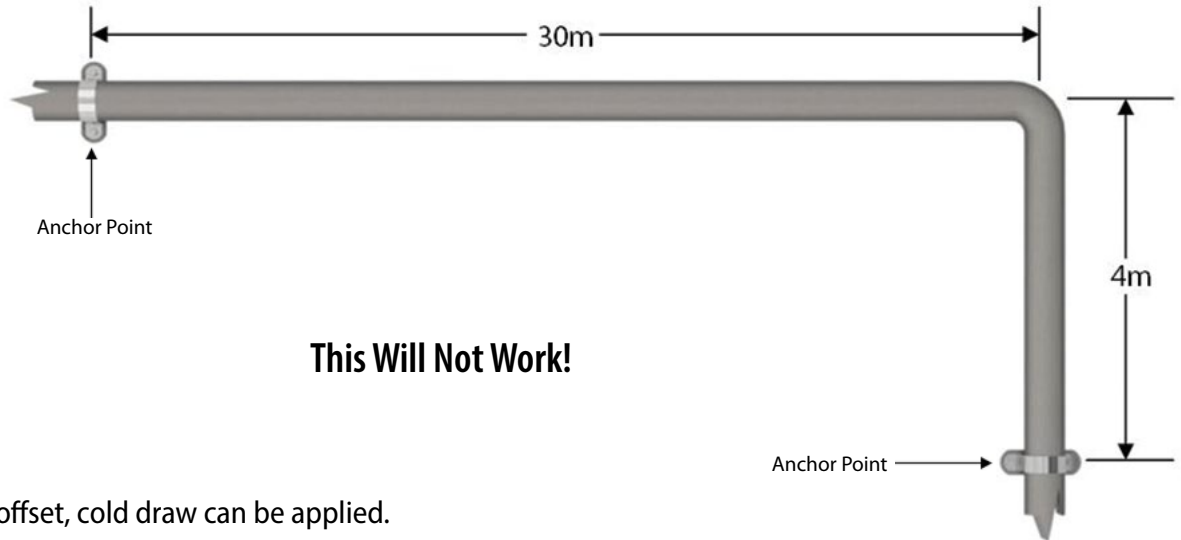

If there is insufficient offset, cold draw can be applied.

Standard practice would be to reduce the length of the pipework or "COLD DRAW" it by 50% of the expected expansion.

Once applied, the pipework is in effect pre-stressed, allowing the offset to take up twice the amount of expansion.

Therefore, if 27.3mm of expansion will require a 5.85m Offset, with 50% cold draw, the expansion is effectively 13.65mm, therefore the offset required will be 3.94m.

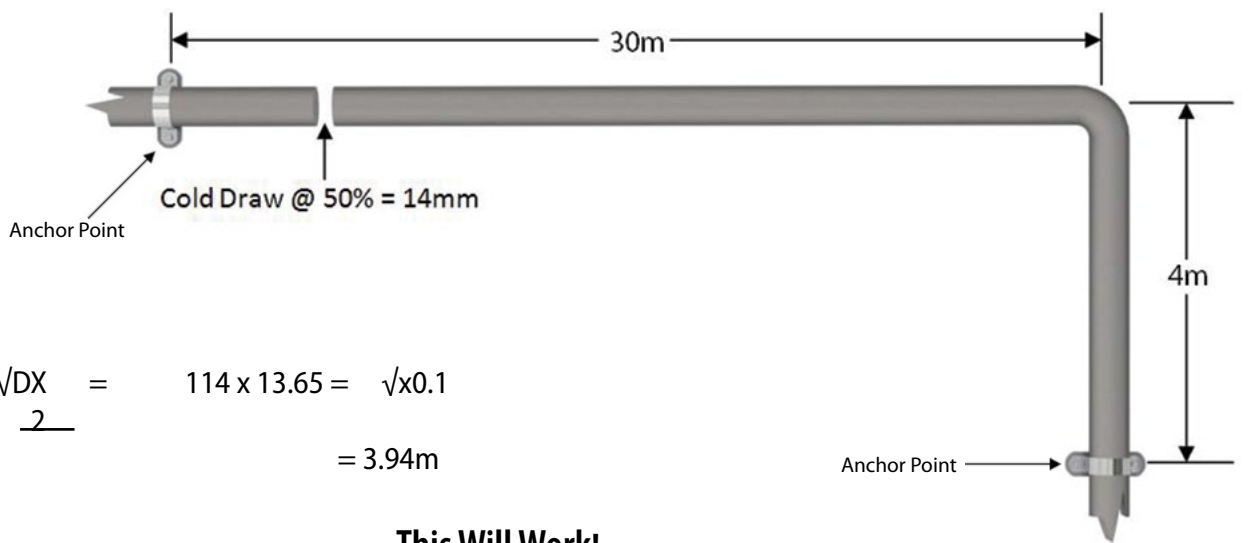

$$\text{Offset } L = 0.1 \frac{\sqrt{DX}}{2} = 114 \times 13.65 = \sqrt{x0.1} = 3.94\text{m}$$

This Will Work!

If the use of expansion devices is not suitable for the application, you may be able to utilise expansion loops to take up the thermal expansion of the pipework. Loops should always be positioned in the middle of a pipe run, with anchors at each end of the run.

Loops are often useful on a drop rod system as axial expansion devices cannot be used on such a system. If you design a loop into a pipework system, we strongly recommend the use of DST Ball Hangers to aid movement.

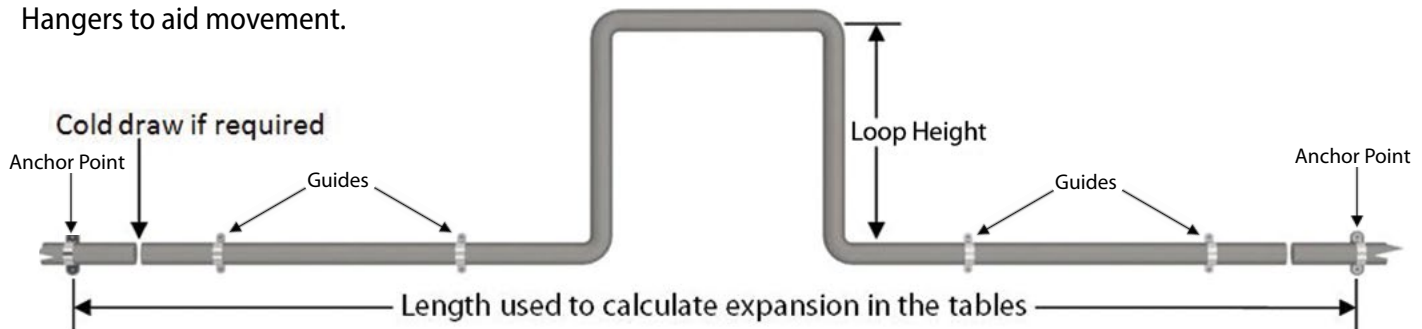

Offset $L = 0.1 \frac{DX}{2}$ For Steel Pipes $L =$ Length of Offset in Metres
 $X =$ Expansion in mm

$D =$ Outside Diameter of Pipe

Offset $L = 0.06 \frac{DX}{2}$ For Copper Pipes

Table Showing Single Offset For Steel Pipes (Without cold draw)

Expansion X	Pipe Nominal Bore											
	15nb	20nb	25nb	32nb	40nb	50nb	65nb	80nb	100nb	125nb	150nb	200nb
1mm	0.32	0.36	0.41	0.46	0.49	0.55	0.62	0.67	0.75	0.84	0.92	1.05
3mm	0.56	0.64	0.71	0.79	0.85	0.95	1.07	1.15	1.31	1.45	1.59	1.82
5mm	0.72	0.82	0.92	1.02	1.09	1.22	1.38	1.49	1.69	1.87	2.05	2.35
10mm	1.02	1.16	1.30	1.45	1.55	1.73	1.94	2.11	2.39	2.65	2.89	3.31
15mm	1.25	1.50	1.59	1.77	1.89	2.12	2.39	2.58	2.92	3.24	3.55	4.06
20mm	1.45	1.64	1.84	2.05	2.19	2.45	2.76	2.98	3.38	3.74	4.09	4.69
30mm	1.77	2.01	2.26	2.51	2.68	3.00	3.38	3.65	4.13	4.58	5.01	5.74
40mm	2.05	2.32	2.61	2.89	3.09	3.46	3.89	4.22	4.77	5.29	5.79	6.63
60mm	2.50	2.84	3.19	3.54	3.79	4.24	4.77	5.17	5.58	6.48	7.09	8.12
80mm	2.89	3.29	3.69	4.09	4.38	4.89	5.11	5.97	6.75	7.48	8.19	9.93
100mm	3.24	3.67	4.12	4.58	4.89	5.48	6.16	6.67	7.54	8.37	9.17	10.48

Table Showing Single Offset For Copper Pipes (Without cold draw)

Expansion X	Pipe Nominal Bore											
	15nb	22nb	28nb	35nb	42nb	54nb	67nb	76nb	108nb	133nb	159nb	219nb
1mm	0.16	0.19	0.22	0.25	0.27	0.31	0.35	0.37	0.44	0.49	0.53	0.63
3mm	0.28	0.34	0.38	0.43	0.48	0.54	0.60	0.64	0.76	0.85	0.92	1.08
5mm	0.56	0.44	0.50	0.56	0.61	0.69	0.77	0.83	0.98	1.09	1.19	1.40
10mm	0.59	0.63	0.71	0.79	0.87	0.98	1.09	1.17	1.39	1.55	1.69	1.98
15mm	0.63	0.77	0.87	0.97	1.06	1.21	1.34	1.43	1.71	1.89	2.07	2.43
20mm	0.73	0.89	1.00	1.12	1.22	1.39	1.55	1.65	1.97	2.19	2.39	2.81
30mm	0.90	1.09	1.23	1.37	1.51	1.71	1.90	2.03	2.41	2.67	2.93	3.43
40mm	1.04	1.26	1.42	1.59	1.73	1.97	2.19	2.34	2.79	3.09	3.38	3.97
60mm	1.27	1.54	1.74	1.94	2.12	2.41	2.69	2.86	3.42	3.79	4.14	4.86
80mm	1.47	1.77	2.01	2.24	2.46	2.78	3.11	3.31	3.94	4.38	4.78	5.62
100mm	1.64	1.99	2.24	2.51	2.75	3.12	3.47	3.69	4.41	4.89	5.35	6.28

Cold draw can be used if the size of the loop cannot be accommodated. The rate of cold draw is normally 50% of the total movement. If the pipework is suspended using drop rods, it would be advisable to use DST Ball Hangers to reduce stresses as the pipework moves.

Drop Rod Calculation Example:

Calculation of Drop Rod Length = $\Delta \times \tan 5^\circ$

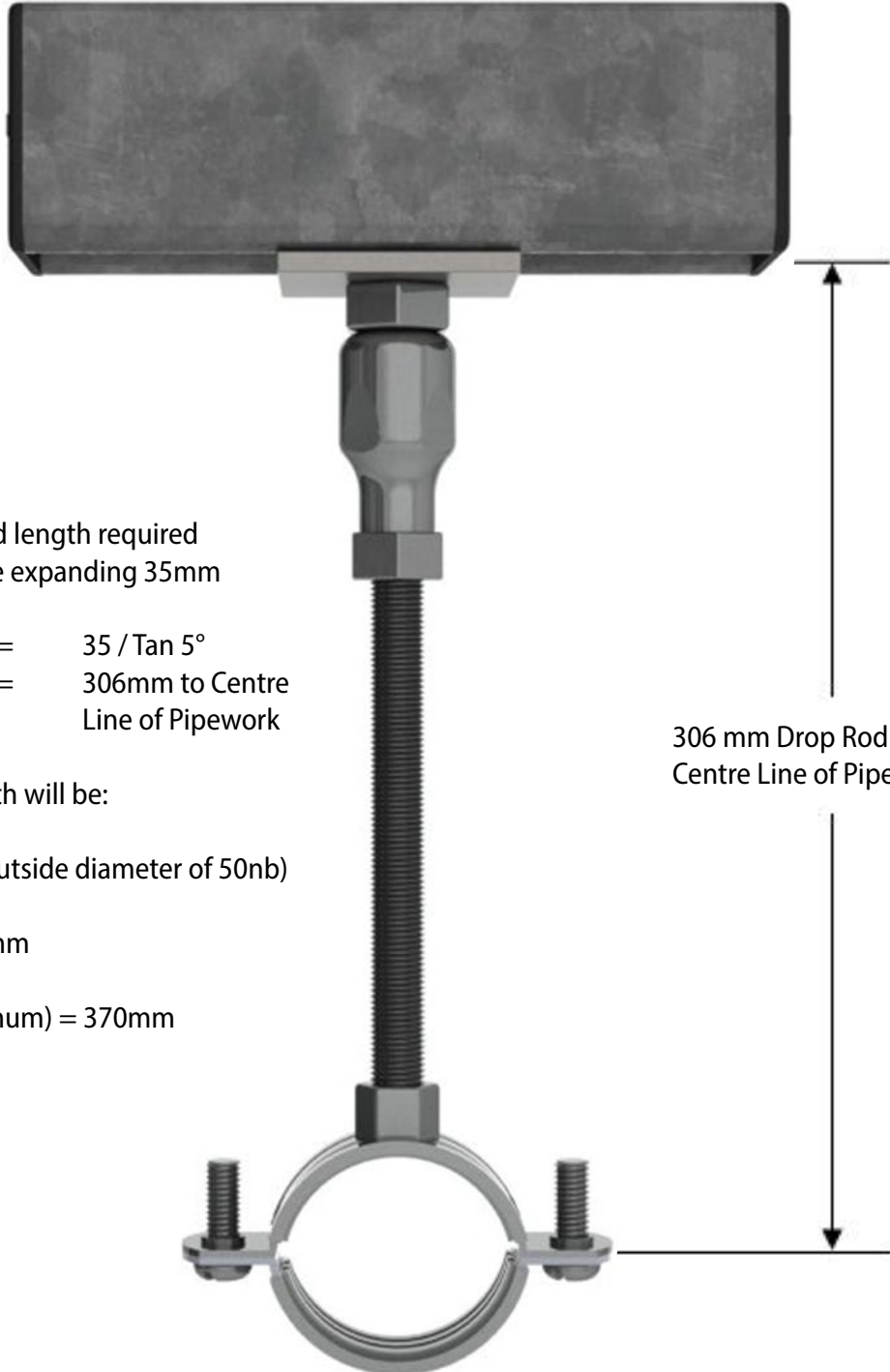

To Calculate the drop rod length required for a length of 50nb pipe expanding 35mm

$$\begin{aligned} \text{Expansion in mm} &= 35 / \tan 5^\circ \\ &= 306\text{mm to Centre Line of Pipework} \end{aligned}$$

Therefore drop rod length will be:

400mm – ½ of 60mm (outside diameter of 50nb)

400mm – 30mm = 276mm

Drop Rod Length (minimum) = 370mm

306 mm Drop Rod Length to Centre Line of Pipework

If the drop rod length required is too long for the installation, DST Ball Hangers or DST Hemispherical Cups and Washers can be used to increase the movement, but decrease the drop rod length. Further advice can be given by one of our Technical Sales Engineers.

Pipe Anchors for AX1, AX2 and AX3 Expansion Compensators

Pipe anchors are needed to overcome the forces set up when axial bellows and under pressure. The following conditions can exist:

Pipeline under test pressure

Pipeline under working pressure and temperature

Each condition must be investigated:

- Pipeline under test pressure - this force is made up of test pressure multiplied by the effective area.
- Pipeline under working pressure and temperature - the force is made up of three components;
 - a. The force to overcome internal pressure; i.e working pressure multiplied by effective area.
 - b. The force to compress the expansion joint . This is calculated by using the force to compress in Newtons/mm.
 - c. The force to overcome the friction of pipe movement, which can be estimated at 30N per metre of pipeline for each 25mm of pipe diameter. This assumes about the worst possible condition of face to face sliding supports. Coefficient of friction about 0.4. If hangers or rollers are used, reduce the figure of 15N per metre of pipeline.

Thus the Total Force = a + b + c

Expansion joints should not be removed during a pressure test. The purpose of a pressure test is to put the pipeline under stresses greater than those which occur under working conditions. If the expansion joints are removed the anchors and guides are not subjected to any stresses and therefore faults in their design will not show up.

When positioning anchors, great care should be taken to ensure that the main structure to which the anchor is attached, is in fact strong enough to withstand the forces transmitted by the anchor. Also ensure that when a number of pipes are anchored at one point, the total force under working conditions is considered.

Bellow is an example showing the anchor forces set up under different conditions.
In these examples 1bar = 100kN/m²



Calculate the anchor force for a 25m long pipeline of 32mm NB at 6 bar working pressure and temperature of 82°C, using modular slide guides.

At 82°C the expansion in mm/metre is 1.0 Therefore the total expansion is 1.0 x 25 = 25mm

Test pressure is 1.5 x working pressure = 1.5 x 6 = 9 bar (=900 kN/m²)

Effective area can be taken from the product catalogue, in this case = 16cm²

For a pipeline under the test conditions, TOTAL FORCE = test pressure x effective area = 900 x 16 x 0.1 = 1,440 N

Working Pressure of 6 (=600 kN/m²)

For a pipeline under working conditions, TOTAL FORCE = a + b + c

a = 600 x 16 x 0.1 = 960 N

b = 15 x 25 = 375N

c = 15 x 25 x $\frac{32}{25}$ = 480 N

therefore, TOTAL FORCE = 960 + 375 + 480 = 1,815N

Pipe Anchors Using Lateral/Angular Expansion Compensators FA1, FA2, AN1, AN2, GI1, GI2

It is preferable to install the above type of Expansion Compensators if the engineer has concerns over Anchor Loads. The Anchor Loads created by the use of these units are significantly lower than the load created by using an Axial Expansion Compensator.

Anchor Loads using Lateral / Angular Expansion Compensators are created from Two Fields.

1. The Force To Deflect The Expansion Compensator.
2. The Force Created Due to Frictional Resistance.

■ Example



1. The Force To Deflect. This information can be found earlier in this guide for DST Type DST/AN1/PN16. In this case 100mm it will be:

$$\begin{aligned} \text{Force to Deflect Each Expansion Compensator} &= 98 \text{ N / deg} \times 2 \\ &= 196.00 \text{ Newtons} \end{aligned}$$

2. Force To Overcome Friction. In this example we will be bracketing using DST 114 Roller Chair and Guide, which has a frictional resistance of 30 Newtons.

$$\text{Force To Overcome Frictional Resistance} = 15 \times 90 \times \frac{100}{25} = 5400 \text{ Newtons}$$

Therefore The total Anchor Force Will Be:

$$1 = 196 \text{ Newtons} \quad + \quad 2 = 5400 \text{ Newtons}$$

$$\text{Anchor Load Total} = 5596 \text{ Newtons}$$

As you can see the majority of the Anchor Load is made up from the frictional resistance of pipework bracketry. It is advisable to use Pipework Bracketry which has a low frictional resistance such as a DST 253 Slide Guide. Please seek further advise from our technical sales team on frictional resistance and futher Pipework Bracketry.

These types of Expansion Compensators are can be used on a Drop Rod system.



DST 102 - Saddle Guide

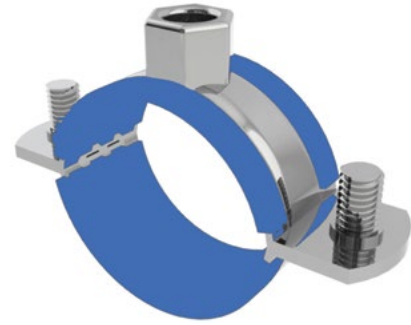

DS Guide Clips



DST LF1, LF2 & LF3
Low Friction Slide Guide



DST 132 - Nylon Coated Saddle
Guide C/W Polypropylene Strip



DST240 (O) - Oversized Brass
Munsen Ring



DST MS1 & MS2
Modular Slide Guide



DST 253G - PTFE Slide Guide
Bracket



DST 253S - PTFE Skid Bracket

Nominal Size	Flange Table	Outer Ø	Nº of Bolt Holes	Bolt Hole Ø	Bolt Circle (P.C.D)	Nominal Size	Flange Table	Outer Ø	Nº of Bolt Holes	Bolt Hole Ø	Bolt Circle (P.C.D)
15mm 1/2"	E	95	4	14	67	80 mm 3"	E	184	4	18	146
	F	95	4	14	67		F	203	8	18	165
	H	114	4	18	83		H	203	8	18	165
	150	89	4	16	60		150	191	4	19	152
	300	95	4	16	67		300	210	8	22	168
	6	80	4	11	55		6	190	4	18	150
	10	95	4	14	65		10	200	8	18	160
	16	95	4	14	65		16	200	8	18	160
20 mm 3/4"	E	101	4	14	73	100 mm 4"	E	216	8	18	178
	F	101	4	14	73		F	229	8	18	191
	H	114	4	18	83		H	229	8	18	191
	150	98	4	16	70		150	229	8	19	191
	300	117	4	19	83		300	254	8	22	200
	6	90	4	11	65		6	210	4	18	170
	10	105	4	14	75		10	220	8	18	180
	16	105	4	14	75		16	220	8	18	180
25 mm 1"	E	115	4	14	83	125 mm 6"	E	254	8	18	210
	F	121	4	18	87		F	279	8	22	235
	H	121	4	18	87		H	279	8	22	235
	150	108	4	16	79		150	254	8	22	216
	300	124	4	19	89		300	279	8	22	235
	6	100	4	11	75		6	240	8	18	200
	10	115	4	14	85		10	250	8	18	210
	16	115	4	14	85		16	250	8	18	210
32 mm 1 1/4"	E	121	4	14	87	150 mm 6"	E	279	8	22	235
	F	133	4	18	98		F	305	12	22	260
	H	133	4	18	98		H	305	12	22	260
	150	117	4	16	89		150	279	8	22	241
	300	133	4	19	98		300	318	12	22	270
	6	120	4	14	90		6	265	8	18	225
	10	140	4	18	100		10	285	8	22	240
	16	140	4	18	100		16	285	8	22	240
40 mm 1 1/2"	E	121	4	14	98	200 mm 8"	E	337	8	22	292
	F	133	4	18	105		F	368	12	22	324
	H	133	4	18	105		H	368	12	22	324
	150	117	4	16	98		150	343	8	22	298
	300	133	4	22	114		300	381	12	25	330
	6	120	4	14	100		6	320	8	18	280
	10	140	4	18	110		10	340	8	22	295
	16	140	4	18	110		16	340	12	22	295
50 mm 2"	E	152	4	18	114	250 mm 10"	E	406	12	22	356
	F	165	4	18	127		F	432	12	25	381
	H	165	4	18	127		H	432	12	25	381
	150	152	4	19	121		150	406	12	25	362
	300	165	8	19	127		300	444	12	29	387
	6	140	4	14	110		6	375	12	18	335
	10	165	4	18	125		10	395	12	22	350
	16	165	4	18	125		16	405	12	26	355
65 mm 2 1/2"	E	165	4	18	127	300 mm 12"	E	457	12	25	406
	F	184	8	18	146		F	489	16	25	438
	H	184	8	18	146		H	489	16	25	438
	150	178	4	19	140		150	482	12	25	432
	300	191	8	22	149		300	521	16	32	451
	6	160	4	14	130		6	440	12	22	395
	10	185	4	18	145		10	445	12	22	400
	16	185	4	18	145		16	460	12	26	410
25	185	8	18	145	25	485	16	30	430		

Key:

- E = BS10 Table 'E'
- F = BS10 Table 'F'
- H = BS10 Table 'H'
- 150 = BS1560 Class 150, ASA 150, ANSI B16.5 Class 150
- 300 = BS1560 Class 300, ASA 300, ANSI BS16.5 Class 300
- 6 = BS4504 PN6, DIN2501 PN6
- 10 = BS4504 PN10, DIN2501 PN10
- 16 = BS4504 PN16, DIN 2501 PN16
- 25 = BS4504 PN25, DIN2501 PN25

Pressure Units

Symbol	Description	Bar	kPa	kN/m ²	psi	atm	m wg
1 bar	Bar		100.0	100.0	14.5037	0.9869	10.1972
1 kPa	Kilopascal	0.01		1.0	0.145	0.0099	0.102
1 kN/m ²	Kilonewton per square metre	0.01	1.0		0.145	0.0099	0.102
1 psi	Pound per square inch	0.0689	6.8948	6.8948		0.0681	0.07031
1 atm	Atmosphere	1.0133	101.3250	101.3250	14.696		10.3323
1 m wg	Metre water gauge	0.0981	9.8067	9.8067	1.422	0.0968	

Vacuum Units

Symbol	Description	mm	Hg in Hg	psi	Torr	bar	atm
1mm Hg	Millimetre of mercury		0.0394	0.49	1.0	0.0013	0.0013
1 in Hg	Inch of mercury	25.4		0.019	25.4	0.00338	0.0334
1 psi	Pound per square inch	51.7	2.04		51.7	0.0689	0.0681
1 Torr	Torr	1.0	0.0394	0.49		0.0013	0.0013
1 bar	Bar	750	29.53	14.5037	750		0.9869
1 atm	Atmosphere	760	29.92	14.696	760	1.0133	

Linear Units

Symbol	Description	mm	cm	m	in	ft	yd
1 mm	Millimetre		0.1	0.001	0.0394	0.0033	0.0011
1 cm	Centimetre	10		0.1	0.3937	0.0328	0.0109
1 m	Metre	1000	100		39.3701	3.2808	1.0936
1 in	Inch	25.4	2.54	0.0254		0.0833	0.0278
1 ft	Foot	304.8	30.48	0.3048	12		0.3333
1 yd	Yard	914.4	91.44	0.9144	36	3	

Weight Units

Symbol	Description	g	kg	t	oz	lb	tn
1 g	Gramme		0.001	0.000001	0.036	0.0022	0.0000098
1 kg	Kilogramme	1000		0.001	36.413	2.2047	0.0009843
1 t	Tonne (metric)	1000000	1000		36413.44	2204.7222	0.984251
1 oz	Ounce	28.4	0.0284	0.0000284		0.0625	0.0000279
1 lb	Pound	453.6	0.4536	0.0004536	16		10.0004465
1 tn	Ton (imperial)	1016000	1016	1.016	35840	2240	

Temperature Units

Symbol	Description	°C	°F	°K
°C	Degree Celsius		Times 1.8, plus 32	Plus 273.16
°F	Degree Farenheit	Minus 32 divide 1.8		Divide 1.8 plus 255.38
°K	Degree Kelvin	Minus 273.16	Minus 255.38	

Pipework & Expansion Guide

Pipe Data Table

Nominal Size	Material	Wall Thickness	Max O/D	Min O/D	Mean I/D	Int Cross Section Area	Metal Cross Section Area	Surface Area	Moment of Inertia	Section Modulus	Pipe Weight	Water Content
		mm	mm	mm	mm	mm ²	mm ²	m ²	cm ⁴	cm ³	kg/m	l/m
15 mm 1/2"	Heavy Steel	3.25	21.7	21.1	14.9	175	186	0.067	0.79	0.736	1.45	0.175
	Medium Steel	2.65	31.7	21.1	16.2	205	155	0.067	0.71	0.656	1.22	0.250
	Copper (Table X)	0.70	15.045	14.965	13.6	145	31.6	0.047	0.08	0.108	0.28	0.145
	Copper (Table Y)	1.00	15.045	14.965	13.0	133	44.1	0.047	0.11	0.145	0.39	0.133
15 mm	Copper (Table Z)	0.50	15.045	14.965	14.0	154	22.9	0.047	0.06	0.080	0.20	0.154
20 mm 3/4"	Heavy Steel	3.25	27.2	26.6	20.4	326	243	0.085	1.75	1.29	1.90	0.326
	Medium Steel	2.65	27.2	26.6	21.6	367	203	0.085	1.50	1.11	1.58	0.367
	Copper (Table X)	0.90	22.055	21.975	20.2	321	59.6	0.069	0.33	0.303	0.52	0.321
	Copper (Table Y)	1.20	22.055	21.975	19.6	302	78.3	0.069	0.43	0.387	0.69	0.302
22 mm	Copper (Table Z)	0.60	22.055	21.975	20.8	340	40.2	0.069	0.23	0.210	0.35	0.340
25mm 1"	Heavy Steel	4.05	34.2	33.4	25.7	518	380	0.106	4.29	2.54	2.97	0.518
	Medium Steel	3.25	34.2	33.4	27.3	586	312	0.106	3.70	2.20	2.44	0.586
	Copper (Table X)	0.90	28.055	27.975	26.2	540	76.7	0.085	0.71	0.504	0.68	0.540
	Copper (Table Y)	1.20	28.055	27.975	25.6	516	101	0.085	0.91	0.650	0.89	0.516
28 mm	Copper (Table Z)	0.60	28.055	27.975	26.83	565	51.7	0.085	0.49	0.347	0.46	0.565
32 mm 1 1/4"	Heavy Steel	4.05	42.9	42.1	34.3	927	490	0.134	9.16	4.31	3.84	0.926
	Medium Steel	3.25	42.9	42.1	35.9	1016	461	0.134	7.74	3.64	3.14	1.016
	Copper (Table X)	0.90	35.07	34.99	32.6	837	128	0.110	1.83	1.043	1.12	0.837
	Copper (Table Y)	1.20	35.07	34.99	32.0	806	158	0.110	2.22	1.270	1.39	0.806
35 mm	Copper (Table Z)	0.70	35.07	34.99	33.6	889	75.5	0.110	1.11	0.635	0.67	0.889
40 mm 1 1/2"	Heavy Steel	4.05	48.8	48.0	40.2	1272	566	0.152	13.98	5.79	4.43	1.271
	Medium Steel	3.25	48.8	48.0	41.9	1376	461	0.152	11.78	4.87	3.61	1.376
	Copper (Table X)	1.20	42.07	41.99	39.6	1234	154	0.132	3.21	1.528	1.36	1.234
	Copper (Table Y)	1.50	42.07	41.99	39.0	1197	191	0.132	3.93	1.869	1.69	1.197
42 mm	Copper (Table Z)	0.80	42.07	41.99	40.4	1284	104	0.132	2.20	1.048	0.91	1.284
50 mm 2"	Heavy Steel	4.50	60.8	59.8	51.3	2070	784	0.189	30.8	10.2	6.17	2.070
	Medium Steel	3.65	60.8	59.8	53.0	2205	651	0.189	26.2	8.7	5.10	2.205
	Copper (Table X)	1.20	54.07	53.99	51.6	2095	199	0.170	7.0	2.573	1.76	2.095
	Copper (Table Y)	2.00	54.07	53.99	50.0	1965	327	0.170	11.1	4.101	2.88	1.965
54 mm	Copper (Table Z)	0.90	54.07	53.99	52.2	2145	150	0.170	5.3	1.963	1.33	2.145
65 mm 2 1/2"	Heavy Steel	4.50	76.6	75.4	67.00	3530	1005	0.239	64.5	170	7.90	3.530
	Medium Steel	3.65	76.6	75.4	68.7	3700	831	0.239	54.5	14.3	6.51	3.700
	Copper (Table X)	1.20	66.75	66.60	64.3	3245	247	0.209	13.2	3.97	2.18	3.245
	Copper (Table Y)	2.00	66.75	66.60	63.1	3125	406	0.209	21.3	6.38	3.58	3.125
67 mm	Copper (Table Z)	1.00	66.75	66.60	64.7	3285	206	0.209	11.1	3.34	1.82	3.285
80 mm 3"	Heavy Steel	4.85	89.5	88.1	79.0	4905	1285	0.279	114	25.6	10.1	4.905
	Medium Steel	4.05	89.5	88.1	80.7	5115	1080	0.279	97.0	21.8	8.47	5.115
	Copper (Table X)	1.50	76.3	76.15	73.2	4210	352	0.239	24.4	6.45	3.11	4.210
	Copper (Table Y)	2.00	76.3	76.15	72.2	4100	467	0.239	31.9	8.43	4.11	4.100
76 mm	Copper (Table Z)	1.20	76.3	76.15	73.8	4280	283	0.239	19.9	5.22	2.50	4.280
100 mm 4"	Heavy Steel	5.40	114.9	113.3	103.3	8380	1840	0.358	272	47.7	14.4	8.380
	Medium Steel	4.50	114.9	113.3	105.1	8680	1540	0.358	231	40.6	12.1	8.680
	Copper (Table X)	1.50	108.25	108.0	105.1	8680	504	0.340	71.4	13.21	4.45	8.680
	Copper (Table Y)	2.00	108.25	108.0	103.1	8355	832	0.340	115	21.41	7.33	8.355
108 mm	Copper (Table Z)	1.20	108.25	108.0	105.7	8780	405	0.340	71.2	10.66	3.57	8.780
125 mm 5"	Heavy Steel	5.40	140.6	138.7	127.7	13050	2270	0.438	520	73.4	17.8	13.05
	Medium Steel	4.85	140.6	138.7	129.8	13250	2065	0.438	470	67.4	16.2	13.25
	Copper (Table X)	1.50	133.5	133.25	130.4	13350	621	0.419	134	20.26	5.47	13.35
	Copper (Table Y)											
133 mm	Copper (Table Z)	1.50	133.5	133.25	130.4	13350	621	0.419	134	20.26	5.47	13.35
150 mm 6"	Heavy Steel	5.40	166.1	164.1	154.3	18700	2700	0.518	862	105	21.2	18.70
	Medium Steel	4.85	166.1	164.1	155.3	18950	2065	0.518	787	95.4	19.2	18.95
	Copper (Table X)	2.00	159.5	159.25	155.4	18950	988	0.501	304	38.42	8.71	18.95
	Copper (Table Y)											
159 mm	Copper (Table Z)	1.50	159.5	159.25	156.4	19200	743	0.501	203	29.09	6.55	19.20
200 mm	Steel	4.88			209.3	34400	3280	0.689	1880	172	25.9	34.42
250 mm	Steel	6.35			260.4	53250	5320	0.859	4745	347	42.0	53.24
300 mm	Steel	7.14			309.6	75300	7080	1.018	8865	547	55.8	75.30

Support Spacing - Space Supports as Table						
Pipe Bore (mm) Nominal	Maximum Support Spacing (m)					
	Steel Pipe		Copper Pipe		Iron Pipe	
	Horizontal	Vertical	Horizontal	Vertical	Horizontal	Vertical
Up to 15	1.8	2.4	1.2	1.8	-	-
20	2.4	3.0	1.4	2.1	-	-
25	2.4	3.0	1.8	2.4	-	-
32	2.7	3.0	2.4	3.0	-	-
40	3.0	3.6	2.4	3.0	-	-
50	3.0	3.6	2.7	3.0	1.8	1.8
65	3.7	4.6	3.0	3.6	-	-
80	3.7	4.6	3.0	3.6	2.7	2.7
100	3.7	4.6	3.0	3.6	2.7	2.7
125	3.7	5.4	3.0	3.6	-	-
150	4.5	5.4	3.6	4.2	3.7	3.7
200	5.0	6.0	-	-	3.7	3.7
250	5.0	6.0	-	-	4.5	5.4
300	6.1	10.0	-	-	8.0	10.0
350	10.0	12.0	-	-	-	-
400	10.5	12.6	-	-	-	-
450	11.0	13.2	-	-	-	-
500	12.0	14.4	-	-	-	-
600	14.0	16.8	-	-	-	-

Pipe Bore (mm) Nominal	Maximum Support Spacing (m)					
	UPVC Pipe		PE Pipe		Glass Pipe	
	Class O,B,C Horizontal	Class D,E,6,7 Vertical	Type 32 Horizontal	Type 50 Vertical	Horizontal	Vertical
Up to 10	-	0.6	0.3	0.45	-	-
15	-	0.6	0.4	0.6	-	-
20	-	0.65	0.4	0.6	-	-
25	-	0.75	0.4	0.6	-	-
32	-	0.8	0.45	0.7	-	-
40	-	0.9	0.45	0.7	0.9	1.7
50	1.1	1.2	0.55	0.85	1.2	1.7
65	1.2	1.4	0.55	0.85	-	-
80	1.4	1.5	0.6	0.9	1.2	1.7
100	1.5	1.7	0.7	1.1	1.2	1.7
125	1.7	1.9	-	-	-	-
150	1.8	2.1	-	1.3	1.2	1.7
175	2.0	2.3	-	-	-	-
200	2.1	2.5	-	-	-	-
225	2.3	2.7	-	-	-	-
250	2.4	2.9	-	-	-	-
300	2.6	3.1	-	-	-	-
350	2.9	3.4	-	-	-	-
400	3.1	3.7	-	-	-	-
450	3.4	3.7	-	-	-	-

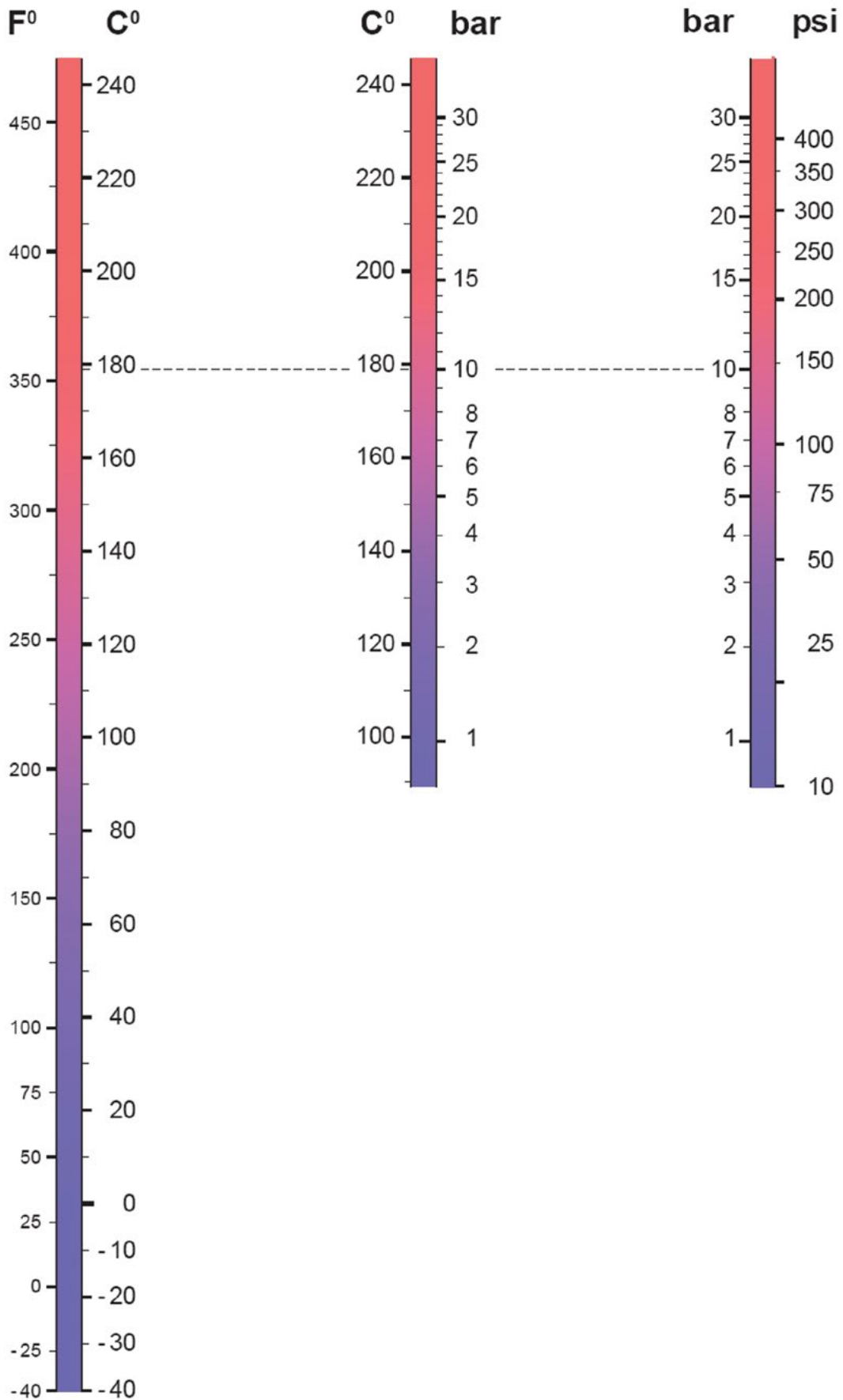

Conversion Tables

Flow Conversion Table

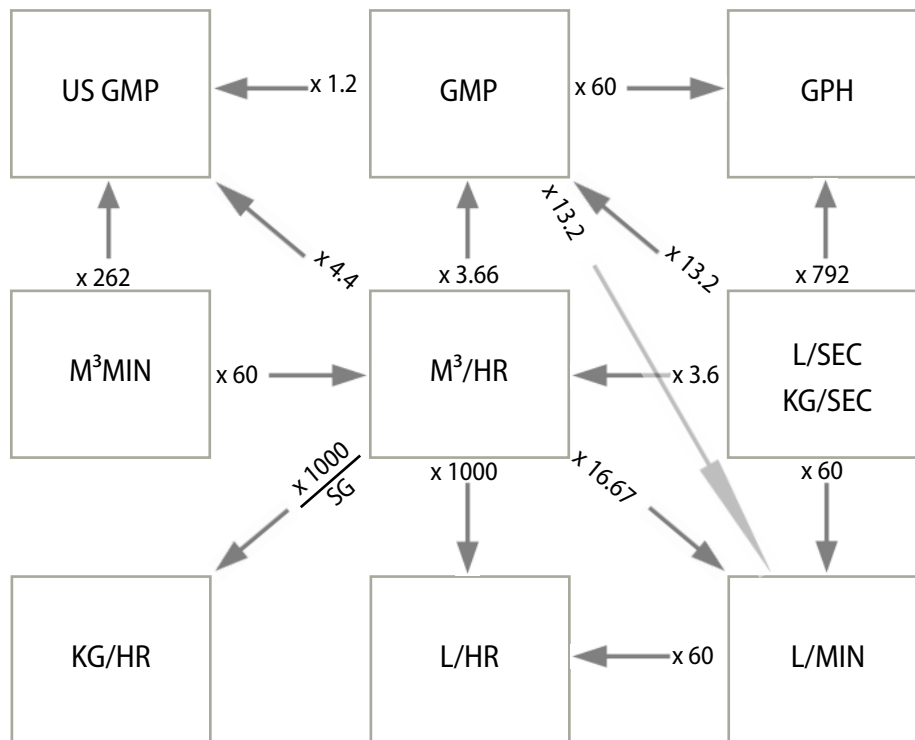

Multiply by conversion factor in direction of arrow.

Divide by conversion factor for opposite requirement, eg. $\text{GPM} \div 13.2 = \text{L/SEC}$

Pressure Conversion Table

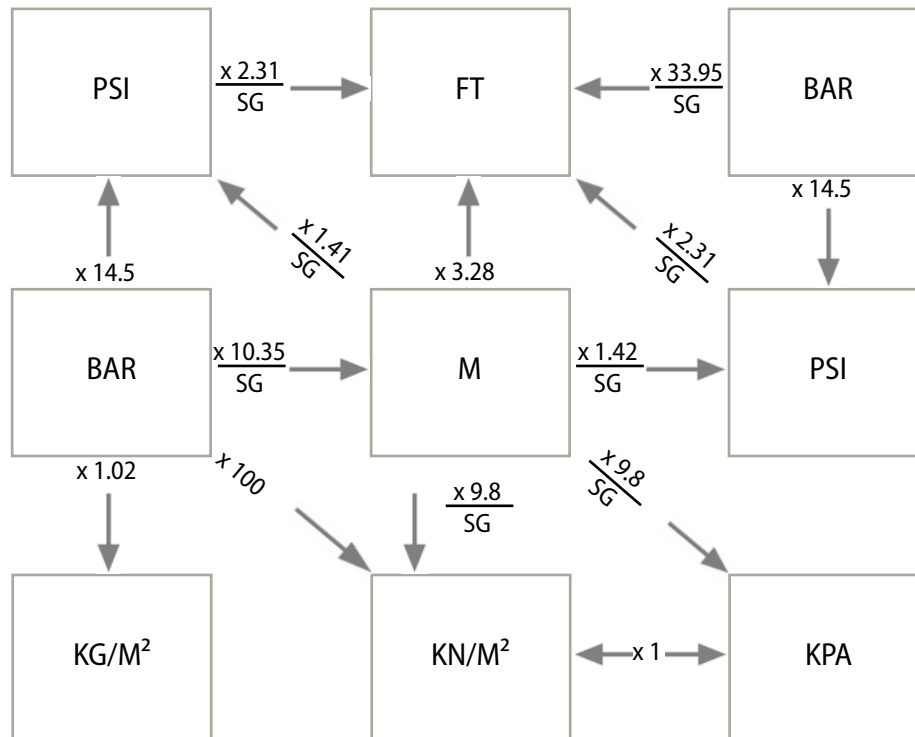

Multiply by conversion factor in direction of arrow.

Divide by conversion factor for opposite requirement, eg. $\text{PSI} \div 1.42 = \text{M}$

DST Group Limited June 2016 STANDARD CONDITIONS OF SALE

1) Interpretation

In these conditions the following terms have the following meaning:-

Seller - DST Group Limited

Buyer - The person, firm or company purchasing the products subject of the contract between the Seller and the Buyer

Products - The goods or materials which shall be the subject of the contract between the Seller and the Buyer

Price - The price specified in the Seller's quotation, acknowledgement, order or otherwise communicated to the Buyer and agreed

2) General

2.1. These conditions prevail over any conditions stipulated by the Buyer, whether express or by implication or incorporation. If the Buyer's documentation shall contain any conditions as to sale and purchase they shall be of no contractual effect between the Seller and the Buyer.

2.2. Save as is otherwise expressly agreed in writing by the Seller or as is expressly provided in these conditions all guarantees, warranties, conditions, representations or stipulations whether expressed or implied and whether arising hereunder or under any prior agreement or statement, or by statute, common law or otherwise are hereby excluded and negated, provided that nothing in this clause or elsewhere in these conditions shall operate to exclude the provisions of Section 12 of the Sales of Goods Act 1979 and the Consumer Rights Act 2015 or to exclude or restrict liability for death or personal injury resulting from the Seller's negligence.

2.3. In the event that the Buyer produces to the Seller at any stage conditions upon which the Buyer will enter any agreement to acquire the Products the terms of these Standard Conditions of Sale shall prevail over the Buyer's conditions in the event of conflict.

3) Orders

3.1. Orders for products shall be in writing and are accepted by the Seller subject to these conditions unless otherwise varied in writing.

3.2. Once an order has been placed by the Buyer it may not be suspended, cancelled or amended without the Seller's prior written agreement. The Buyer shall be responsible for the cost of all purchases, stocks, work-in-progress, labour costs, unrecovered overheads, and other expenses suffered by the Seller as a result of such suspension, cancellation or amendment.

3.3. Products are supplied specifically for the purposes mentioned in the Order/Order Acknowledgement and for no other purposes.

4) The Price

4.1. All prices given, published or put forward are quotations unless otherwise expressly stated therein. Prices quoted are prices prevailing at the date of quotation and are subject to increase. The Seller may at any time before delivery increase the price of the undelivered products or balance of the products by notice in writing to the Buyer. Prices invoiced are prices prevailing at the date of despatch.

4.2. Unless otherwise stated on acceptance, the price of the products shall include the Seller's costs of standard packing, normal insurance and delivery of the products to any one address in the United Kingdom maintained specified in writing by the Buyer and agreed by the Seller prior to delivery.

5) Payment

5.1. Unless otherwise stated on the Seller's invoice or otherwise agreed in writing, payment for the products shall be made not later than thirty days after the end of the month of invoicing but so that the Seller may at any time on or after acceptance by notice in writing to the Buyer vary the terms of payment by demanding immediate payment or (at the Seller's option) adequate security for sums which will be due hereunder.

5.2. Time of payment shall be of the essence and failure by the Buyer to pay the price or any installment thereof in due time shall entitle the Seller to treat such failure as a repudiation of the whole contract by the Buyer and to require the Buyer to make immediate payment of all monies due or become due and to recover from the Buyer damages for such breach of contract and/or (at the Seller's option) to charge interest at four per cent per annum above the base rate of Barclays Bank PLC from due date until payment.

6) Delivery

Unless otherwise agreed in writing between the Seller and the Buyer the following provisions shall apply:-

6.1. Delivery of the products shall have taken place when the products have been delivered to the address specified on the Seller's quotation, acknowledgement or other document or if the Buyer refuses to accept delivery, at the time when the products are due and ready for delivery in such latter instance the Seller shall be entitled to arrange storage for the products and to charge such storage and other costs to the Buyer and

the Buyer shall also be responsible for the payment of interest on any unpaid sum in accordance with clause 5.2.

6.2. The delivery date or dates specified on the Seller's acceptance of order are estimates only. The Seller shall not be liable for failure to deliver by such date or dates or for any damage or loss arising directly or indirectly out of delay in delivery; nor shall the Buyer be entitled to refuse to accept the Products because of late delivery.

6.3. Where delivery is to be made by installments, each delivery shall be deemed for such purpose to be the subject of a separate contract and any failure whatsoever by the Seller in respect of any one delivery shall not entitle the Buyer to repudiate the contract or any installments remaining to be delivered thereunder.

6.4. The risk of any loss or damage to or deterioration of the products shall be borne by the Buyer from the time delivery has taken place in accordance with clause 6.1.

6.5. In respect of sea transit the Seller shall not be required to give the Buyer the notice relating to insurance of the products referred to in Section 32(3) of the Sales of Goods Act 1979 and the Consumer Rights Act 2015.

6.6. The Buyer is deemed to have accepted the Products after a period of 3 days after the date of delivery.

6.7. The Buyer shall make all necessary arrangements to take delivery of the Product on the date when the Products are tendered for delivery.

7) Property

Notwithstanding delivery and the passing of risk:-

7.1. The property in the products shall remain the Seller's until payment in full has been made to the Seller by the Buyer for the products and all other sums due to the Seller at the date of delivery of the products.

7.2. Where full payment has not been made to the Seller and the Buyer uses the products in his manufacturing process or incorporates the products with other products the property in the products shall be retained by the Seller insofar as such products are identifiable and insofar as they are incorporated with other products the Seller's title in the products shall transfer into the product of which the products form a part. The Seller also reserves the right to trace into the proceeds of sale of the products or of the products of which the products form a part to the extent that the Seller remains unpaid.

7.3. Until such payment is made the Buyer shall hold all products and materials the property in which is vested in the Seller on a fiduciary basis only and in any of the events specified above the Buyer shall store such products and materials so as to be marked and clearly identifiable as the property of the Seller in any dispute relating thereto.

7.4. The Buyer grants the Seller the right of entry (by force, if necessary) upon the Buyer's premises to recover the products if the Buyer is in breach.

8) Lien

The Seller shall in respect of all unpaid debts due from the Buyer under the same or any other contract have a general lien on all products and property of the Buyer in its possession (although the products or some of them may have been paid for) and shall after the expiration of fourteen days written notice to the Buyer be entitled to dispose of such products and property as it deems fit, and apply the proceeds towards such debts.

9) Loss/Damage/Storage

9.1. Unless otherwise agreed in writing between the Buyer and Seller the Seller may deliver against any order an excess and/or deficiency up to ten per cent of weight or volume ordered without any liability whatsoever to the Buyer save that the price shall be adjusted accordingly.

9.2. The Buyer shall inspect the products immediately upon delivery and shall within 3 days of such delivery (time being of the essence) give notice in writing to the Seller and the carrier of all claims on account of damage to or total or partial loss of Products in transit. Claims for non-delivery must be submitted in writing to the Seller within fourteen days after notification of despatch. Quality claims must be made in writing immediately after the Buyer learns of the defect and in any event not later than thirty days after the Buyer's receipt of the products. Any claim not made in writing and received by the Seller within the aforesaid time limits shall be deemed waived.

9.3. If the Buyer establishes to the satisfaction of the Seller that products have been damaged in transit or that the consignment is incomplete, the Seller will, at the Seller's option, repair or replace such products or credit the Buyer with the value thereof as appropriate, provided that the Buyer shall have given to the Seller written notification (otherwise than upon the carrier's delivery document) of such damage or shortage as provided in clause 9.2. The Seller shall be permitted a reasonable opportunity to inspect any damaged consignment and to investigate any shortage.

9.4. Save as provided in clause 9.3 above, the Seller shall not be liable to the Buyer for any loss or damage arising out of or in connection with products damaged or shortages.

9.5. If the Seller fails to make delivery or makes defective delivery of any one installment such failure or defective delivery shall not vitiate the contract as regards other installments.

9.6. The right of the Buyer to set off the value of any shortage, defective products or products not otherwise conforming to contract shall be restricted to the specific invoice for the products in question and shall not apply to previous or future accounts.

10) Liability/Limitation and Warranty

10.1. All conditions, guarantees, or warranties express or implied by statute, common law or otherwise including (but without prejudice to the generality of the foregoing) conditions, guarantees or warranties as to quality, fitness for purpose or description of the products or their life or wear or use under any conditions whether known or made known to the Seller or not are hereby excluded.

10.2. The Seller's liability for any and all direct loss or damage resulting to the Buyer from defects in the products or any other cause shall be limited to the purchase price of the quantity of the products in respect of or in relation to which such loss or damage is claimed. The Seller shall not be liable for any loss, damage or expense caused to the Buyer by reason of any labour costs or other expenditure incurred by the Buyer or for any indirect or consequential loss or damage howsoever arising. Subject as aforesaid the Seller shall be under no liability in contract or in tort for any loss or damage or personal injury arising directly or indirectly out of the supply or use of the products or containers other than death or personal injury resulting from the negligence of the Seller within the meaning of Section 1 of the Unfair Contract Terms Act 1977 and the Consumer Rights Act 2015.

11) Force Majeure

11.1. Deliveries may be partially or totally suspended by either party during any period in which it is prevented from manufacturing, delivering or taking delivery of the products through any circumstances outside its control. If because of such circumstances, the Seller is unable to supply the total requirement of the products the Seller may allocate its available supply (after satisfaction of its own requirements) amongst all of its customers, including those not under contract, as the Seller thinks fit. Deliveries so suspended shall be cancelled without liability, but the contract between the parties shall otherwise remain unaffected.

11.2. For the purpose of these conditions, circumstances outside the Seller's control include acts of God, strikes, lock-outs, other industrial action, fire, accident, lightning, earthquakes, storms, floods, explosion, war, governmental restriction and any other circumstances, whether similar or dissimilar, beyond the reasonable control of the Seller.

12) Indemnity

The Buyer shall indemnify the Seller in respect of all damage or injury occurring to any person, firm, company or property and against all actions, suits, claims and demands, charges or expenses in connection therewith for which the Seller may become liable in respect of the products sold under the contract in the event that the damage or injury shall have been occasioned otherwise than by the negligence of the Seller.

13) Default

The Seller reserves the right (without prejudice to its other rights and remedies) either to terminate the contract between the parties or to suspend further deliveries under it or require payment in advance in the event that the Buyer fails to pay for any one delivery when the same becomes due or the Buyer's financial responsibility becomes unsatisfactory to the Seller or if the Buyer, being a company, goes into liquidation or has a receiver appointed or not being a company has a receiving order made against him or enters into any arrangement or composition with creditors.

14) V.A.T.

All prices quoted are exclusive of all import duties, V.A.T. and other imposts which will be for the Buyer's account and should be added to the price as appropriate.

15) Intellectual Property

No representation, warranty or indemnity is given by the Seller that the products do not infringe any letters patent, trademarks, registered designs or other industrial rights.

16) Product Liability

16.1. The Buyer shall ensure that the products are transported, stored, fitted and used in accordance with any specifications or instructions which the Seller may provide.

16.2. The Buyer shall ensure that customers of the products incorporating the products shall be warned of the nature of the products and shall be given any information in respect of any claims made against the Seller where the Buyer has failed to comply with clause 16.1 above.

17) Assignability

The contract of which these conditions form part is personal to the Buyer and the benefit thereof shall not be assigned without the Seller's written consent.

18) Proper Law

These conditions and the contract between the parties shall be construed and applied in accordance with the Law of England and the English Courts shall have sole jurisdiction in any dispute relating thereto.

